

CONTINENTAL
OVERHAUL MANUAL
FOR AIRCRAFT ENGINE
MODELS
C75, C85, C90 & O-200

FOREWORD

This manual is published for the guidance of all facilities engaged in operation, maintenance and overhaul of four cylinder engines of the Teledyne Continental C and O-200 Series.

A description is included in this manual of the various models and special equipments of the series and photographs selected to illustrate the major differences between models. The Table of Specifications provides more detailed information in regard to features and performance of the models. It should be noticed that such descriptive material is neither intended nor adequate to enable conversion of any model to another in instances in which such conversion is permissible. For detailed information regarding application of parts and their interchangeability, refer to the Spare Parts Catalog. For model and series number conversion instructions, refer to the Teledyne Continental Service Bulletin on that subject.

Service maintenance instructions relative to accessories installed on Teledyne Continental aircraft engines in our factory are reprinted herein by permission of the accessory manufacturers. Instructions for overhaul of these accessories may be obtained direct from the manufacturers or through their authorized service facilities.

All descriptive and dimensional information and all instructions contained in this edition have been revised and extended to cover all four cylinder models of the Teledyne Continental C Series in current production. The parts catalog section is not included in this edition, since it is subject to frequent change in details.

A manual of this scope cannot be revised often enough to be kept up to date at all times, since it is our policy to improve details of engine design in the interest of maximum safety and utility of our products whenever the results of our continuous experimental and development program indicate the desirability of replacing the old with something even better. For this reason we issue Service Bulletins to our Approved Distributors to advise of important changes in parts, desirable inspections and precautions found necessary in operation and maintenance. These bulletins are available for reading at all Teledyne Continental Approved Service Stations. Those who need permanent copies of Service Bulletins may obtain them by direct mail, as issued, from the factory Publications Department on an annual subscription basis. A nominal charge is made to cover the cost of mailing.

It is suggested that a careful study of the text of this manual will provide the reader with knowledge of engine construction and of techniques for both operation and repair work which, if applied in practice, will promote safety in flight and long engine life.

If, in spite of the high quality of materials and the careful inspection and testing of these engines, any defect is suspected, the question should be brought immediately to the attention of the nearest Teledyne Continental Approved Service Station so that a diagnosis and any necessary correction may be made.

TABLE OF CONTENTS

| Section & Para. | Title | Page | Section & Para. | Title | Page |
|--------------------|---------------------------------------------------------------------|------|--------------------|-------------------------------------------|------|
| I | Introduction..... | 9 | 5-4 | Indefinite Storage | 32 |
| 1-1 | Model Designation..... | 9 | 5-5 | Procedure For Return of A/C to Service.. | 33 |
| 1-2 | Definitions and Abbreviations..... | 9 | 5-6 | Indefinite Storage Inspection..... | 33 |
| 1-3 | Measurement | 10 | | | |
| 1-4 | Cleanliness | 10 | VI | Installation in Airplane & Removal..... | 34 |
| II | Table of Specifications..... | 11 | 6-1 | Mounting the Engine..... | 34 |
| III | General Description..... | 16 | 6-2 | Fuel Systems..... | 38 |
| 3-1 | Difference Between Model Groups..... | 16 | 6-3 | Oil System | 38 |
| 3-2 | Significance of C Series Dash Numbers and Letters..... | 16 | 6-4 | Propeller Installation..... | 38 |
| 3-3 | Model Conversions..... | 16 | 6-5 | Engine Removal | 39 |
| 3-4 | Optional Equipment..... | 17 | VII | Operating Instruction..... | 40 |
| 3-5 | Superseding Parts..... | 17 | 7-1 | Procedure Preliminary to Starting..... | 40 |
| 3-6 | Crankcase Construction..... | 17 | 7-2 | Starting Procedure..... | 40 |
| 3-7 | Crankshafts | 18 | 7-3 | Warm-Up | 40 |
| 3-8 | Nitrided Crankshafts..... | 18 | 7-4 | Ground Test | 40 |
| 3-9 | Crankshaft Gears..... | 19 | 7-5 | Take-Off | 41 |
| 3-10 | Connecting Rods..... | 19 | 7-6 | Climbing | 41 |
| 3-11 | Camshafts | 19 | 7-7 | Level Flight | 41 |
| 3-12 | Camshaft Gears | 19 | 7-8 | Let-Down and Landing..... | 42 |
| 3-13 | Hydraulic Valve Lifters | 20 | 7-9 | Stopping the Engine..... | 42 |
| 3-17 | Pushrods and Housings..... | 21 | 7-10 | Lubricating Oil | 42 |
| 3-18 | Piston Assemblies | 21 | 7-11 | Viscosity..... | 42 |
| 3-19 | Cylinder Assemblies..... | 21 | 7-12 | Oil Change Periods | 42 |
| 3-25 | Crankcase Cover Assembly for -12, -14, -16 & 0-200 Models..... | 22 | 7-13 | Oil Change Procedure..... | 43 |
| 3-26 | Crankcase Cover Assembly for -8 Models. 23 3-27 Gear Train | 23 | 7-14 | Engine Fuel | 43 |
| 3-28 | Carburetor Induction System..... | 24 | VIII | Engine Troubles and Service Repairs | 44 |
| 3-29 | Oil Sumps..... | 24 | IX | Periodic Inspection and Maintenance..... | 48 |
| 3-30 | 3-30 Ignition System | 24 | 9-1 | Daily Inspection | 48 |
| 3-36 | Delco-Remy Starter..... | 25 | 9-2 | First Fifty Hour Inspection..... | 48 |
| 3-37 | Prestolite Starter | 26 | 9-3 | 100-Hour Periodic Inspection..... | 49 |
| 3-38 | Generator and Drive..... | 26 | X | Adjustment and Minor Repair..... | 51 |
| 3-39 | Side Mounted Fuel Pump..... | 26 | 10-1 | Carburetors..... | 51 |
| 3-40 | Duel Fuel Pump Equipment..... | 26 | 10-7 | Magnetos | 53 |
| 3-41 | Lubrication System..... | 27 | 10-18 | Replacement of Ignition Cables..... | 57 |
| IV | Unpacking the Engine..... | 29 | 10-24 | Delco-Remy Starter..... | 59 |
| 4-1 | Shipping Crates | 29 | 10-30 | Prestolite Starter..... | 60 |
| 4-2 | Method of Packing and Preservation..... | 29 | 10-38 | Generator and Drive..... | 62 |
| 4-3 | Removal of Engine from Crate..... | 30 | 10-47 | Hydraulic Valve Lifters..... | 64 |
| 4-4 | Preparation for Installation..... | 30 | XI | Disassembly | 67 |
| V | Storage of Engines | 31 | 11-1 | Preliminary Operations..... | 67 |
| 5-1 | General | 31 | 11-10 | Disassembly | 68 |
| 5-2 | Flyable Storage | 31 | | | |
| 5-3 | Temporary Storage | 31 | | | |

TABLE OF CONTENTS (Con't)

| Section & Para. | Title | Page | Section & Para. | Title..... | Page |
|--------------------|---------------------------------------------------|------|--------------------|---------------------------------------------|------|
| XII | Cleaning | 72 | XVI | Final Assembly | 97 |
| 12-1 | Materials and Processes. | 72 | 16-1 | General Procedure. | 97 |
| 12-6 | Specific Parts | 72 | 16-4 | Detailed Procedure. | 97 |
| XIII | Inspection | 74 | XVII | Testing after Overhaul. | 106 |
| 13-1 | Definitions | 74 | 17-1 | Testing Equipment | 106 |
| 13-2 | Inspection Tools | 74 | 17-2 | Test Stand | 106 |
| 13-5 | Inspection Methods | 75 | 17-3 | Instruments | 106 |
| 13-14 | Inspection of Critical Parts. | 77 | 17-4 | Test Club | 106 |
| XIV | Repair and Replacement. | 81 | 17-5 | Test After Overhaul | 106 |
| 14-1 | General Repair | 81 | 17-6 | Preservation. | 111 |
| 14-7 | Repair and Replacement of Specific Parts | 82 | 17-7 | Fuel and Lubricating Oil. | 111 |
| 14-13A | Crankcase Modification. | 87 | 17-8 | Testing Engines Installed in Aircraft. | 111 |
| 14-21 | Protective Coatings. | 90 | 17-9 | Inspection | 111 |
| XV | Assembly of Subassemblies. | 93 | XVIII | Table of Limits | 114 |
| 15-1 | General Procedure. | 93 | | | |
| 15-4 | Detailed Procedure | 93 | | | |

LIST OF TABLES

| Section & Para. | Title | Page | Section & Para. | Title | Page |
|--------------------|-----------------------------------------------------------------|------|--------------------|----------------------------------------------------|------|
| I | Features Common to all Models. | 11 | XIV | Accessory Drive Speed Ratios and Rotation | 14 |
| II | Type Certificate Numbers | 11 | XV | Line and Instrument Connections. | 14 |
| III | Features Peculiar to Each Model Group | 11 | XVI | Weights of Standard Engine Equipment. | 15 |
| IV | Dimensions Peculiar to Each Model or Model Dash Number. | 11 | XVII | Additional Weights of Optional Equipment | 15 |
| V | Speed and Power Ratings. | 12 | XVIII | Recommended Oil Viscosity Grades | 43 |
| VI | Operating Temperature Limits. | 12 | XIX | Magnflux Inspection Data. | 77 |
| VII | Operating Pressure Limits | 12 | XX | Stud Identification Chart. | 81 |
| VIII | Model or Model Dash Number Equipment | 12 | XXI | Test Operating Limits. | 109 |
| IX | General Ignition System Specifications | 13 | XXII | Test Schedule | 110 |
| X | Ignition Timing | 13 | XXIII | Oil Sump Capacity | 111 |
| XI | Valve Mechanism Specifications. | 13 | XXIV | General Use -Tightening Torques. | 118 |
| XII | Lubrication System Specifications. | 13 | XXV | Pipe Plugs | 118 |
| XIII | Fuel Metering System Specifications | 14 | | | |

LIST OF ILLUSTRATIONS

| Figure No. | | Page |
|---------------|--------------------------------------------------------------------------------------------------|------|
| 1. | Left Side View, Model C85-12F | 6 |
| 2. | Three-Quarter Right Rear View, Model C85-12 | 6 |
| 3. | Three-Quarter Left Front View, Model C90-16F | 7 |
| 4. | Three-Quarter Right Rear View, Model C90-16F | 7 |
| 5. | Right Front View, Model C-90 | 8 |
| 6. | Left Front View, Model O-200 | 8 |
| 7. | Cylinder Arrangement Diagram (Top View) | 10 |
| 8. | Section Through Hydraulic Valve Lifter | 20 |
| 9. | Crankcase Cover and Accessories of -12, -14, -16 and O-200 Models. | 22 |
| 10. | Gear Train of -12,-14,-16 and O-200 Models | 24 |
| 11. | Hoisting Engine by Crankshaft Lifting Eye | 29 |
| 12. | Typical Installation Diagram for -12,-14 & -16 Models, Side View | 35 |
| 13. | Installation Drawing for -12, -14 & -16 Models, Front View. | 35 |
| 14. | Installation Drawing for -12, -14 & -16 Models, Rear View. | 36 |
| 15. | Installation Drawing for -12, -14 & -16 Models, Side and Top Views. | 37 |
| 16. | Engine Mounting Equipment of Models C90-14 & 16 and 0-200 | 38 |
| 17. | Ignition Wiring Diagram. | 57 |
| 18. | Removal of Hydraulic Unit from Valve Lifter Body. | 69 |
| 19. | Compressing Valve Spring to Remove Locks | 71 |
| 20. | Removing Plunger from Hydraulic Unit with Taped Pliers. | 71 |
| 21. | Installing Helical Coil Inserts | 82 |
| 22. | Dimensions of Rocker Shaft Boss Bushings | 84 |
| 23. | Drill Fixture | 87 |
| 24. | Drilling Hole in Bearing. | 88 |
| 25. | Drilling Adapter Assembly. | 88 |
| 26. | Plug Detail. | 89 |
| 27. | Drill Fixture | 89 |
| 28. | Drill Fixture Installed | 89 |
| 29. | Name Plate Change | 89 |
| 30. | Tightening No.1 Connecting Rod Bolts | 95 |
| 31. | Installing Crankshaft Bearing and Old Type Thrust Washer. | 97 |
| 32. | Installing Crankshaft and Connecting Rods | 98 |
| 33. | Installing Dowel Type Thrust Washers and Split Oil Seal. | 98 |
| 34. | Installing Starter Pinion Pivot | 99 |
| 35. | Installing Crankcase 1, 3 Side on 2, 4 Side | 99 |
| 36. | Installing Crankcase Cover on -12, -14, -16 and O-200 Models. | 102 |
| 37. | Installing No.3 Cylinder | 103 |
| 38. | Installing "O" Rings on Intake Manifold Studs | 103 |
| 39. | Placing Crankshaft in Firing Position of No.1 Piston. | 104 |
| 40. | Placing Flange Crankshaft in Firing Position of No.1 Piston. | 104 |
| 41. | Fuel Flow Limits vs. R.P.M. at Propeller Load, Model C90 | 112 |
| 42. | Fuel Flow Limits vs. R.P.M. at Propeller Load, Models C75 and C85. | 112 |
| 43. | Fuel Flow Limits vs. R.P.M. at Propeller Load, Model 0-200. | 113 |
| 44. | Limits and Lubrication Chart (Sheet 1 of 4) -Cross Section View. | 120 |
| 45. | Limits and Lubrication Chart (Sheet 2 of 4) -Longitudinal Section View. | 121 |
| 39. | Limits and Lubrication Chart (Sheet 3 of 4) -Rear View & Horizontal Section -8 Models. | 122 |
| 40. | Limits and Lubrication Chart (Sheet 4 of 4) -Rear View & Sections, -12,-14and O-200 Models | 123 |

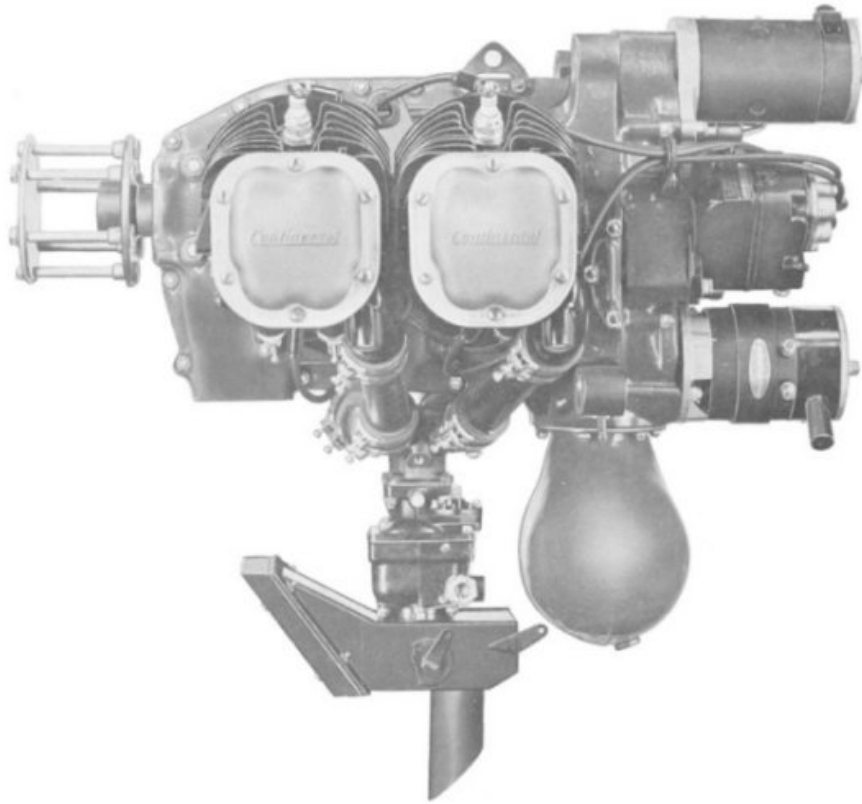

Figure 1. Left Side View, Model C85-12F.

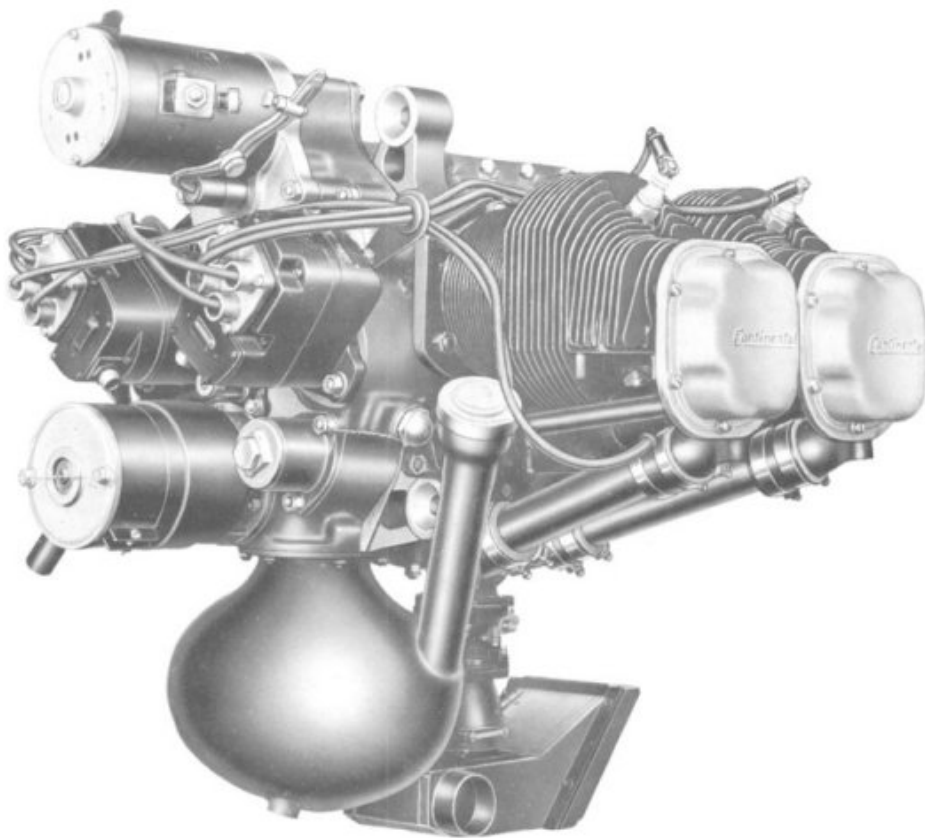

Figure 2. Three-Quarter Right Rear View, Model C85-12.

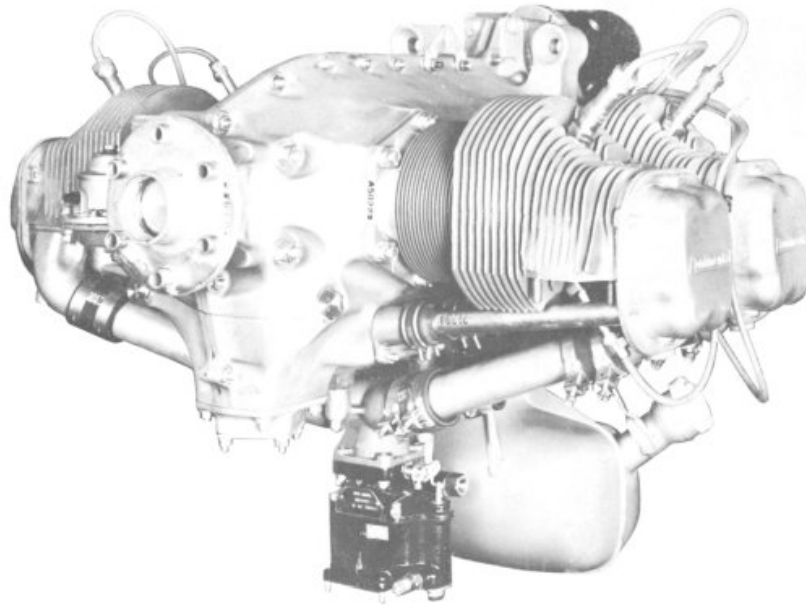

Figure 3. Three-Quarter Left Front View, Model C90-16F.

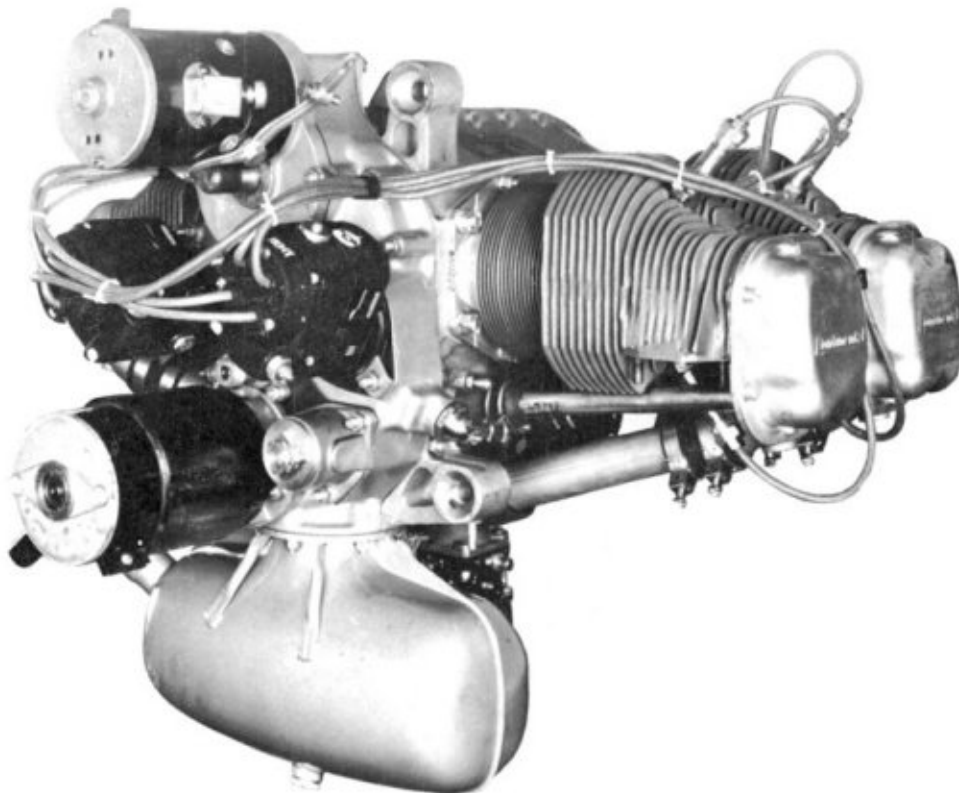

Figure 4. Three-Quarter Right Rear View, Model C90-16F.



Figure 5. Right Front View, Model C90.

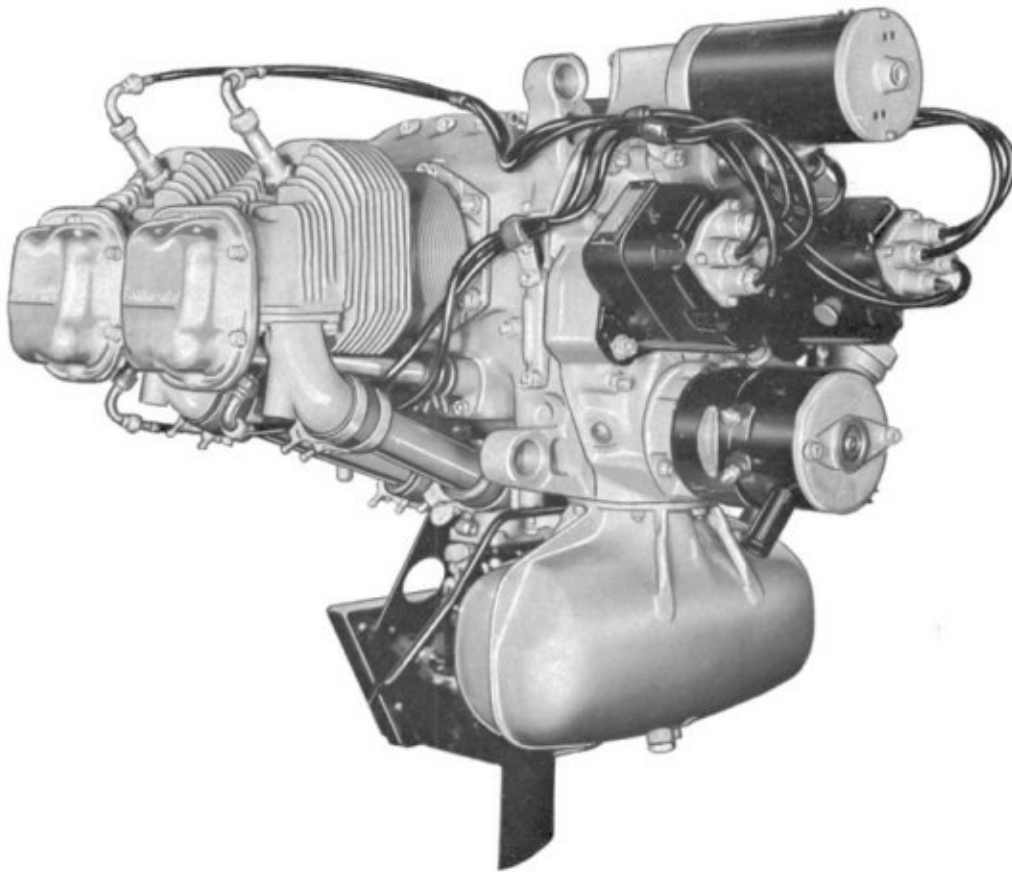

Figure 6. Left Rear View, Model O-200.

SECTION I

INTRODUCTION

1.1 MODEL DESIGNATIONS.

This publication covers the maintenance and overhaul instructions applicable to the four cylinder C Series and the O-200 Aircraft Engines. C Series Engines covered by this publication fall into three model groups, namely, C75, C85 and C90, according to normal rated horsepower. Within each C model group, variations in equipment of the basic engine are denoted by suffix dash numbers, as explained in the Table of Specifications. Further explanation of the meaning of model dash numbers applicable to C models will be found in Section III. Each engine bears an identification plate, on which is stamped the information peculiar to that particular model, including the exact model and dash number designation and the engine serial number.

NOTE

If a new nameplate is required, refer to Service Bulletin M75-5.

All correspondence with Teledyne Continental Distributors and with the factory Service Department in regard to specific engines should refer to the exact model designation and serial number.

1-2. DEFINITIONS & ABBREVIATIONS

| |
|---------------------------------------------------------------------------------------------------------------------------------------------------------------------------------------------------------------------------------------------------------------------------------------------------------------------------------------------------------------|
| <p>A. B. C. After Bottom Center Approx. Approximately A. T. C. After Top Center Bar. Barometric B. B. C. Before Bottom Center B. H. P. Brake Horsepower B. T. C. Before Top Center F. A. A. Federal Aviation Administration</p> |
|---------------------------------------------------------------------------------------------------------------------------------------------------------------------------------------------------------------------------------------------------------------------------------------------------------------------------------------------------------------|

| |
|------------------------------------------------------------------------------------------------------------------------------------------------------------------------------------------------------------------------------------------------------------------------------------------------------------------------------------------------------------------------------------------------------------------------------------------------------------------------------------------------------------------------------------------------------------------------------------------------------------------------------------------------------------------------------------------------------------------------------------------------------------------------------------------------------------------------------------------------------------------------------------------------------------------------------------------------------------------------------------------------------------------------------------------------------------------------------------------------------------------------------------------------------------------------------------------------------------------------------------------------------------------------------------------------------------------------------------------------------------------------------------------------------------------------------------------------------------------------------------------------------------------------------------------------------------------------------------------------------------------------------------------------------------------------------------------------------------------------------------------------|
| <p>C. F. M. Cubic Feet Per Minute C. G. Center of Gravity Dia. Diameter ° Degree of Angle ° F. Degrees Fahrenheit Fig. Figure (Illustration) Front Propeller End Ft. Foot or Feet G. P. M. Gallons Per Minute H₂O Water Hg. Mercury I.D. Inside Diameter In. (") Inches Hex. Hexagon Hr. Hour Left Side Side on Which No's 2 & 4 Cylinders Located Lbs. Pounds Lockwire Soft Steel Wire Used to Safety Connections, Etc. Man. Manifold or Manometer Max. Maximum Min. Minimum 30' Thirty Minutes of Angle (60' Equals One°) N. P. T. National Pipe Thread (Tapered) N. C. National Coarse (Thread) N. F. National Fine (Thread) O. D. Outside Diameter Press. Pressure P. S. I. Pounds Per Square Inch Rear Accessory End of Engine Right Side Side on Which No's 1 & 3 Cylinders Located R. P. M. Revolution Per Minute Std. Standard T. D. C. Top Dead Center Temp. Temperature Torque Force X Lever Arm (125 ft. lbs. torque = 1251bs. Force Applied One Ft. From Bolt Center or 62-1/2 lbs. Applied 2 Ft. From Center)</p> |
|------------------------------------------------------------------------------------------------------------------------------------------------------------------------------------------------------------------------------------------------------------------------------------------------------------------------------------------------------------------------------------------------------------------------------------------------------------------------------------------------------------------------------------------------------------------------------------------------------------------------------------------------------------------------------------------------------------------------------------------------------------------------------------------------------------------------------------------------------------------------------------------------------------------------------------------------------------------------------------------------------------------------------------------------------------------------------------------------------------------------------------------------------------------------------------------------------------------------------------------------------------------------------------------------------------------------------------------------------------------------------------------------------------------------------------------------------------------------------------------------------------------------------------------------------------------------------------------------------------------------------------------------------------------------------------------------------------------------------------------------|

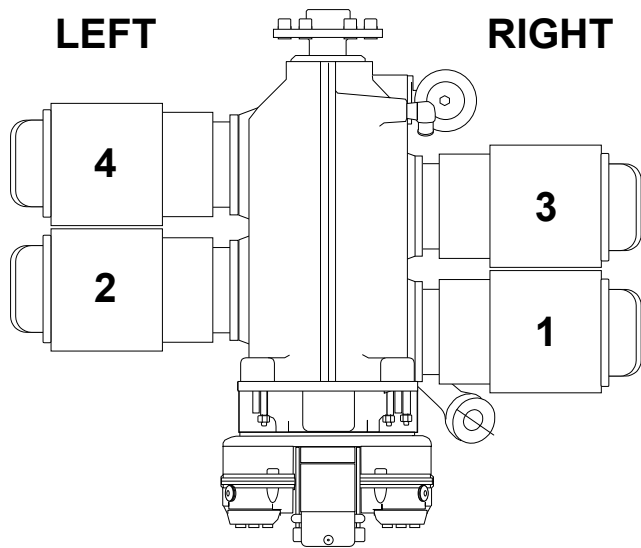

Figure 7. Cylinder Arrangement Diagram (Top View)

1-3. MEASUREMENT

Throughout this manual are instructions regarding measurement of parts dimensions and proper tightening of nuts and screws. The importance of accuracy in these operations cannot be over-emphasized. All necessary data will be found in the Table of Limits. A chart provides a visual reference to locations of the points where measurements are to be made.

1-4. CLEANLINESS

Every effort should be made to keep engines free from external accumulations of foreign matter and to prevent the entrance of abrasive particles.

SECTION II TABLE OF SPECIFICATIONS

TABLE I. FEATURES COMMON TO ALL MODELS

| | |
|-----------------------------------|----------------------|
| Type of Engine: | Horizontally Opposed |
| Operating Cycle: | Otto (4 stroke) |
| Number of Cylinders: | 4 |
| Type of Cooling System: | Air Cooled |
| Overall Width of Engine: | 31-1/2 inches |
| Number of Mounting Bolts: | 4 |
| Diameter of Mounting Bolts: | 3/8 inch |
| Cylinder Bore: | 4-1/16 inches |
| Direction of Crankshaft Rotation: | Clockwise |

TABLE II. TYPE CERTIFICATE NUMBERS

| Model | C75 | C85 | C90 | O-200 |
|-------------------------|-----|-----|-----|-------|
| Type Certificate Number | 233 | 233 | 252 | 252 |

TABLE III. FEATURES PECULIAR TO EACH MODEL GROUP

| Model | C75 | C85 | C90 | O-200 |
|---------------------------------------|-------|-------|-------|-------|
| Piston Stroke (inches) | 3-5/8 | 3-5/8 | 3-7/8 | 3-7/8 |
| Total Piston Displacement (cubic in.) | 188 | 188 | 201 | 201 |
| Compression Ratio | 6.3:1 | 6.3:1 | 7.0:1 | 7.0:1 |

TABLE IV. DIMENSIONS PECULIAR TO EACH MODEL OR MODEL DASH NUMBER

| Model or Model Dash Number (C75, C85, C90) | -8 | -8F | -12 | -12F | -14F | -16F | O-200 |
|-----------------------------------------------------|-----------|-----------|-----------|-----------|-----------|-----------|------------|
| Overall Height ... | 27-55/64" | 27-55/64" | 28-3/4" | 28-3/4" | 28-3/4" | 28-3/4" | 28-3/4" |
| Overall Length ... | 30-1/2" | 29-13/32" | 32-23/64" | 31-11/32" | 31-11/32" | 31-11/32" | *27-17/32" |
| Center of Gravity Location ahead of Crankcase | | | | | | | |
| Rear Surface ... | 6-1/4" | 6-1/4" | 4-19/32" | 4-19/32" | 4-19/32" | 4-19/32" | 4-19/32" |
| Below Crankshaft | | | | | | | |
| Centerline | 1-1/2" | 1-1/2" | 1-11/32" | 1-11/32" | 1-11/32" | 1-11/32" | 1-11/32" |

TABLE V. SPEED AND POWER RATINGS

| Model | C75 | C85 | C90 | O-200 |
|-----------------------------------------|------|------|------|-------|
| Normal Rated RPM | 2275 | 2575 | 2475 | 2750 |
| Take-off RPM (Max. 5 minutes) | 2275 | 2575 | 2625 | 2750 |
| Normal Rated Brake Horsepower | 75 | 85 | 90 | 100 |
| Take-off Brake Horsepower | 75 | 85 | 95 | 100 |

TABLE VI. OPERATING TEMPERATURE LIMITS

| Model | C75 | C85 | C90 | O-200 |
|----------------------------------------------------|-----|-----|-----|-------|
| Maximum Cylinder Head Temperature (°F) | 550 | 540 | 525 | 525 |
| Maximum Cylinder Base Temperature (°F) | 300 | 300 | 275 | 290 |
| Maximum Magneto Temperature (°F) | 160 | 160 | 170 | 170 |
| Maximum Oil Temperature at Screen (°F) | 225 | 225 | 225 | 225 |
| Minimum Oil Temperature at Take-off (°F) | 75 | 75 | 75 | 75 |

* To front of crankshaft flange.

TABLE VII. OPERATING PRESSURE LIMITS

| Model | C75 | C85 | C90 | O-200 |
|------------------------------------------------------|-------|-------|------------|------------|
| Oil Pressure for Cruising (psi) | 30-60 | 30-60 | 30-60 | 30-60 |
| Min. Oil Press. at Idling Speed (psi) | 10 | 10 | 10 | 10 + |
| *Static Gravity Fuel Press. at Carb. (psi) | 1/2 | 1/2 | **6 Max. | **6 Max. |
| *Pump Feed Fuel Press. at Carb. (psi) | 2-4 | 2-4 | **3.5-4.75 | **3.5-4.75 |
| Min. Carb. Air Entrance Press. (in. HO) | 6 | 6 | | - |
| Max. Carb. Air Entrance Press. (in. HO) | 12 | 12 | | - |

* For setting float level.

** For Marvel carburetors.

+ With Hot Oil.

TABLE VIII MODEL OR MODEL DASH NUMBER EQUIPMENT

| Model or Dash Number (C75, C85, C90) | -8 | -8F | -12 | -12F | -14F | -16F | O-200 |
|-------------------------------------------|------|------|------|------|------|------|-------|
| S.A.E. No. 0 Taper Crankshaft | X | | X | | | | |
| S.A.E. Type 1 Flange Crankshaft | | X | | X | X | X | X |
| Stromberg NA-S3A1 Carburetor | X | X | X | X | X | | |
| *Marvel-Schebler MA-3SPA Carb. | Opt. | Opt. | Opt. | Opt. | Opt. | X | X |
| Lord Mount Bushings | | | | | X | X | X |
| Delco-Remy Electric Starter | | | X | X | X | X | X |
| Delco-Remy Electric Generator | | | X | X | X | X | X |
| Vacuum Pump Adapter | | | | | | X | X |

TABLE IX. GENERAL IGNITION SYSTEM SPECIFICATIONS

| Model or Model Dash Number (C75, C85, C90) | -8 | -12 | -14 | -16 | O-200 |
|--------------------------------------------------|----------|----------|----------|----------|----------|
| *Unfinished Eisemann Magneto Model | AM-4 | | | | |
| *Radio Shielded Eisemann Magneto Model | | LA-4 | | | |
| Radio Shielded Bendix Magneto Model | S4RN-21 | S4LN-21 | S4LN-21 | S4LN-21 | S4LN-21 |
| **Slick Magneto | 447/4000 | 447/4000 | 447/4000 | 447/4000 | 447/4000 |
| Number of Magnetos | 2 | 2 | 2 | 2 | 2 |
| Number of Spark Plugs | 8 | 8 | 8 | 8 | 8 |
| Firing Order C75, C85, C90, O-200 | 1,3,2,4 | 1,3,2,4 | 1,3,2,4 | 1,3,2,4 | 1,3,2,4 |

*Approved for C75 and C85 only
 **Approved for C90 and O-200 only

TABLE X IGNITION TIMING

| Model | C75 | C85 | C90 | O-200 |
|------------------------------------------------------|-----|-----|-----|-------|
| Right Magneto Fires Upper Plugs (° B.T.C.) | 28 | 28 | 26 | 24 |
| Left Magneto Fires Lower Plugs (° B.T.C.) | 30 | 30 | 28 | 24 |

TABLE XI VALVE MECHANISM SPECIFICATIONS

| Model | C75 | C85 | C90 | O-200 |
|--------------------------------------------------------------------|-----------|-----------|-----------|-----------|
| Type of Valve Mechanism | Overhead | Overhead | Overhead | Overhead |
| Hydraulic Valve Lifters Installed | X | X | X | X |
| Valve To Rocker Clearance (Operating) | 0 | 0 | 0 | 0 |
| Valve To Rocker Clearance (Lifters Deflated) (inches) | .030-.110 | .030-.110 | .030-.110 | .030-.110 |
| Valve Lift (inches) | 0.382 | 0.382 | 0.410 | 0.410 |
| Intake Valve Opens (° B.T.C.) | 8 | 8 | 9 | 21 |
| Intake Valve Closes (° A.B.C.) | 57 | 57 | 56 | 58 |
| Exhaust Valve Opens (° B.B.C.) | 49 | 49 | 50 | 65 |
| Exhaust Valve Closes (° A.T.C.) | 16 | 16 | 15 | 14 |

TABLE XII LUBRICATION SYSTEM SPECIFICATIONS

| Model | C75 | C85 | C90 | O-200 |
|------------------------------------------------|-----|-------|-----|-------|
| Pressure Oil Pump Installed | X | X | X | X |
| Oil Sump Capacity (U.S. Quarts) | 4 | 4-1/2 | 4.8 | 6 |
| Average Oil Consumption (Pints/Hour) | 1/5 | 1/4 | 1/3 | 1/3 |

TABLE XIII. FUEL METERING SYSTEM SPECIFICATIONS

| Model | C75 | C85 | C90 | O-200 |
|-----------------------------------------------|---------|---------|---------|---------|
| Stromberg Carburetor Model | NA-S3A1 | NA-S3A1 | NA-S3A1 | — |
| Marvel-Schebler Carburetor Model | — | — | MA-3SPA | MA-3SPA |
| *Parts List Number (Stromberg) | 380162 | 380167 | 380231 | — |
| Part Number (Marvel-Schebler) | — | — | 627367 | 627143 |
| Mixture Control | Manual | Manual | Manual | Manual |
| *Venturi Diameter (inches) | 1-5/16 | 1-3/8 | — | 1-1/2 |
| *Main Metering Jet (drill size No.) | 46 | 45 | — | — |
| *Main Air Bleed (drill size No.) | 60 | 60 | — | — |
| **Minimum Octane Rating of Fuel | 80/87 | 80/87 | 80/87 | 80/87 |

* For specifications of other carburetors furnished as optional equipment, refer to Service Bulletin on this subject.

** 100LL Optional

TABLE XIV ACCESSORY DRIVE SPEED RATIOS AND ROTATION

| Name | C' Shaft: Drive Speed Ratio | Direction of Drive Rotation |
|-----------------------------------------------------|-----------------------------|-----------------------------|
| Tachometer Drive (-12 and O-200 Models) | 1:0.5 | Clockwise* |
| Tachometer Drive (-8 Models) | 1:0.5 | Counterclockwise* |
| Magneto Drive (-12 and O-200 Models) | 1:1 | Clockwise* |
| Magneto Drive (-8 Models) | 1:1 | Counterclockwise* |
| Oil Pump Driving Impeller | 1:0.5 | Counterclockwise* |
| Starter Armature (-12 and O-200 Models) | 1:35.7 | Clockwise* |
| Generator Armature (-12 and O-200 Models) | 1:2.035 | Counterclockwise* |
| Fuel Pump Lever | 1:0.5 | Reciprocating |
| Vacuum Pump Drive O-200 | 1:1 | Counterclockwise† |

* Rotation as viewed from rear of engine.

† Rotation when facing driving pad.

TABLE XV LINE AND INSTRUMENT CONNECTIONS

| Connection | Location | Size |
|-----------------------------------------|----------------------------|-----------------|
| Primer Jet Hole | Int. Man. & Cyl. Hd. | 1/8 in. N.P.T. |
| Fuel Inlet | Stromberg Carb. | 1/4 in. N.P.T. |
| Fuel Inlet | Marvel-Schebler Carburetor | 1/4-18 N.P.S.F. |
| Mixture Control Lever Hole | Carburetor | 1/4 in. Dia. |
| Throttle Lever Cable Hole | Carb. Man. | 3/16 in. Dia. |
| Carb. Heat Control Lever Hole | Carb. Air Scoop | 3/16 in. Dia. |
| Carb. Heat Control Lever Hole | Carb. Air Scoop | 13/64 in. Dia. |
| Hot Air Inlet | Carb. Air Scoop | 2 in. Dia. |
| Fuel Inlet and Outlet | Fuel Pump | 1/8-27 N.P.S.F. |
| Oil Pressure Gauge Line | Crankcase (right) | 1/8 in. N.P.T. |
| Oil Temperature Capillary | Oil Screen Cap | 5/8-18 N.F. |
| Tachometer Drive Cable | Tach. Drive Shaft | AS-54, Type 1 |
| Starter Lever Cable Hole | Starter Lever | 13/64 in. Dia. |
| Generator Blast Tube | Gen. Brush Cover | 7/8 in. Dia. |
| Breather Tube | Breather Elbow | 5/8 I.D. Hose |

TABLE XVI WEIGHTS OF STANDARD ENGINE EQUIPMENT

| Description | Weight (in lbs.) |
|-----------------------------------------------------------------------------------|------------------|
| Basic Engine (Model C85-8) | 157.8 |
| Basic Engine (Models C85-8F, C90-8F) | 158.84 |
| Basic Engine (Models C75-12, C85-12) | 167.56 |
| Basic Engine (Models C75-12F, C85-12F, C90-12F, C90-14F) | 168.6 |
| Basic Engine (Model C90-16F, O-200) | 170.18 |
| Stromberg Carburetor, Type NA-S3A1 (C75-8-12) | 2.56 |
| Marvel-Schebler Carburetor, Type MA-3SPA (C85, C90-8-12-14-16F & O-200) | 2.62 |
| Two Magnetos (Bendix S4RN-21 or S4LN-21) | 12.12 |
| Eight Shielded Spark Plugs | 1.75 |
| Unshielded Ignition Cable Assembly | 1.82 |
| Shielded Ignition Harness Assembly (Model O-200) | 3.81 |
| Delco-Remy Starter (-12,-14,-16 and O-200) | 15.50 |
| Delco-Remy Generator (-12,-14,-16 and O-200) (12 Volt, 20 Amp) | 10.12 |
| Propeller Hub Assembly (-8 and -12) | 4.39 |
| Carburetor Air Intake and Filter Assembly (used with Stromberg Carburetors) | 2.38 |
| Carburetor Air Intake and Filter Assembly (used with Marvel-Schebler Carburetors) | 3.12 |
| Propeller Attaching Parts (-8F, -12F, -14F, -16F & O-200) | 1.7 |
| Eight Rubber Mount Bushings, Four Steel Washers | 0.55 |
| Domestic Shipping Crate | 70 |
| Export Shipping Crate | 142 |

TABLE XVII ADDITIONAL WEIGHTS OF OPTIONAL EQUIPMENT

| Description | *Weight (in lbs.) |
|------------------------------------------|-------------------|
| Radio Shielded Ignition Cable Assembly | 1.06 |
| Eight Shielded Spark Plugs | 1.75 |
| Harrison Oil Cooler Equipment (complete) | 4.25 |
| AC Fuel Pump | 1.71 |

NOTE: (*) Add stated weights of corresponding standard equipment (if any) to obtain weight of optional equipment.

SECTION III GENERAL DESCRIPTION

3-1. DIFFERENCE BETWEEN MODEL GROUPS.

Models within the C series are grouped according to rated power, the groups being 75, 85 and 90. These three model numbers are prefixed by the series designation "C". Models in the C75 group differ from the corresponding dash numbered models in the C85 group only in calibration of the carburetor installed. C90 models differ from C75 and C85 models in the design of several major parts and accessories, including the crankshaft, camshaft, crankshaft gear (in -8 models only), carburetor, oil sump, connecting rods, pistons and valve springs. The O-200, in turn, differs from C Series in the design of its crankcase, camshaft, crankcase cover, carburetor and oil sump. It differs further in that shielded ignition is standard equipment. As indicated in Table III, C90 and O-200 models have a longer piston stroke, resulting in a higher compression ratio and larger piston displacement. A higher fuel octane rating is required by these features.

3-2. SIGNIFICANCE OF C SERIES DASH NUMBERS AND LETTERS

Following the series letter and power designation, and separated from them by a dash, a figure and, in some instances, a suffix letter or two in the complete model number denote the installation of certain parts or equipment designed to adapt the basic engine to various classes of aircraft. Those dash numbers and suffix letters which have been used to identify production models built to date are as follows:

- 8: No provisions for starter or generator.
- 12: Starter, generator and associated parts installed.
- 14: Lord Engine Mount Bushings installed. Otherwise like -12 models.
- 16: Vacuum Pump Adapter. Otherwise like -12 models.

F: Flange type crankshaft installed (replaces tapered shaft).

H: Crankcase and crankshaft adapted to feed oil to hydraulic controllable pitch propeller.

Various combinations of the foregoing dash numbers and suffix letters are used to describe equipment of the different models. In the following discussions and instructions the term "-12 models" will indicate all models equipped with starter and generator, whether or not they have flange crankshafts (1.2F). The absence of a suffix letter in the model number, as C75-12, indicates that a tapered crankshaft is installed. The Lord mount bushing equipment of C90-14 and O-200 models is illustrated in Figure 16.

3-3. MODEL CONVERSIONS.

Conversion of C75 and C85 models to corresponding dash numbered C90 models is not approved, due to the nature and extent of parts differences and to the possibility of unsatisfactory results. It is not possible to convert any -8 model to a -12 model, because the -8 crankcase is not adaptable to the -12 crankcase cover in several respects. Conversion of -12 models to -8 models is not approved for similar reasons. Neither -8 nor -12 models can be converted to -14 models in the field because of the special machining required for Lord mount bushings. Conversion of C75 models to corresponding dash numbered C85 models may be accomplished in accordance with instructions contained in our Service Bulletin on this subject. Installation of a flange crankshaft in place of tapered shaft is considered merely a crankshaft replacement and does not require factory approval or special instructions, however, engine identification plates bearing model or dash numbers, other than those originally assigned, cannot be issued unless an application for conversion approval has been submitted and approved by the factory Service Department.

3-4. OPTIONAL EQUIPMENT.

While the assignment of model numbers, as described above, represents an attempt to establish categories of engines of the same basic design and to denote the equipment installed, any extension of the list of model numbers, intended to specify in detail the optional parts installed to adapt engines to all aircraft installations, would be of little or no value, since these requirements change frequently, and since optional equipment may be replaced by other parts in the field. Accordingly, engines are equipped with certain optional types of part, such as oil sumps, accessories, and equipments (or systems), such as radio shielded ignition, as specified by the purchaser, and no attempt is made to denote such installations in the engine model designation. Unshielded ignition systems are standard equipment on all C series engines. Shielded ignition systems are standard on the O-200. Stromberg type NA-S3A1 carburetors are standard on all C75, CBS and earlier C90 engines and are designed for gravity feed. Type NA-S3A1 carburetors designed for use with pump feed systems are available. Marvel-Schebler type MA-3SPA carburetors are standard for O-200 and current production C90 engines. Oil sumps are shaped to suit various aircraft in regard to location, capacity and length of the filler neck. The oil gage rod assemblies are located in the oil filler neck and are marked per customer's specification for capacity.

3-5. SUPERSEDING PARTS.

Whenever possible, parts of improved design are made to fit into existing engines so that modernization of older assemblies requires replacement of only the redesigned part. This is not always possible, because some parts are so related that a change in one necessitates a corresponding change in the other. Service Bulletins list serial numbers of engines which require new type parts for modernization. When a superseding part is not interchangeable with the original type of part, the old style part is kept in stock for maintenance of the older engines.

3-6. CRANKCASE CONSTRUCTION.

Aluminum alloy castings which form the left and right halves of the crankcase are machined flat and smooth along their parting surfaces. Upper and lower flanges are attached by fourteen hex head screws, washers, and plain nuts, two of which also attach the engine lifting eye to the upper flanges. Each casting has two cylinder mount pads machined in its vertical side. Cylinder openings in pads on the two sides of the case are not quite opposite. Each casting has a heavy lateral web at the rear, another near the center and a third

near the front. These webs are cut out for ventilation and oil drainage and have enlarged bosses at the case parting surface for crankshaft and camshaft bearings. Seats for steel backed, precision inserts of the crankshaft main bearings are line bored through the web bosses, and camshaft bearings are bored directly in the case metal. These bearings are all divided equally by the parting surface, camshaft bearings being directly below the main bearings. Earlier case halves of the C series engines are prevented from spreading by eight through studs installed in the bosses above and below the main bearings and one stud below the rear camshaft bearing. Current production C series and all O-200 case halves are retained by six through studs installed in the bosses above and below the front and rear main bearings, two through bolts installed in lieu of the two through studs at the center bearing bosses and one through stud below the rear camshaft bearing. In addition to the through studs or through bolts, cylinder mount pads have short studs to make a total of six in each. Cylinder pads and case webs are stiffened by ribs cast inside the case. A counterbore around the crankshaft opening in the front of the case receives the crankshaft oil seal. In current production crankcases, the shoulder behind the oil seal recess is deeper than in older cases to make a better oil baffle. The long boss for the front main bearing in early C series production cases had two dowels, driven through longitudinal holes on the horizontal centerline, to engage holes at the mid-points of semi-circular thrust washers which were installed at front and rear ends of the bearing. In later C series crankcases, the two halves of each washer were different. One half had a short rivet at its mid-point to fit into a notch in the bearing boss. The other half was plain. These washers were installed with the split perpendicular to the case parting surface, whereas the original type washer split was in line with the parting surface.

A groove has been added to each end of the front main bearing boss to accommodate thrust washers on the O-200. Old style cases not having this groove must be serviced with flanged front main bearings.

A notch is provided to accept the tang of these bearings. Below each cylinder pad, and on the horizontal plane of the camshaft, two lateral bosses inside the case are bored to form valve lifter guides. These bores emerge at the case side surface, and a pushrod housing adapter, installed over their open ends, is retained by three case studs and nuts. Between the line of lifter guides and the line of cylinder

openings at each side of the case are the main oil galleries extending from front to rear. The oil galleries are plugged at the front. Current C series crankcases use a 5/8-18 hex head plug and annular gasket. Earlier C series and current O-200 crankcases use (2) 3/8 NPT countersunk hex pipe plugs. An enlargement of each casting's lower parting flange at the front end forms half of a boss which is machined and studded to make a mount pad for a vacuum pump on the -16 and O-200. A semicircular flange at the rear of the crankcase bottom surface is machined flat and studded to form the front half of the oil sump mount pad. Two studs driven into bosses at the lower parting flanges are used for attachment of the intake manifold. The crankcase breather elbow is screwed into a tapped boss ahead of No.3 cylinder. An upper and a lower arm at the rear of each case casting affords an engine mounting point. For -8, -12 and -16 models the end bosses of mounting arms have front and rear conical recesses for rubber mount bushings. The arm bosses of -14 and O-200 model crankcases are bored through and counterbored for Lord mount bushing assemblies. Parts of the Lord mount assembly are illustrated in Figure 16. The flange surrounding the rear end of the crankcase is machined flat and studded for attachment of the crankcase cover. Locations and lengths of the studs are different in -8 and -12 crankcases. The crankcase of -12, -14, -16 and O-200 models has a hole bored through the rear web above the rear main bearing to hold the starter pinion pivot. A dowel driven into the left side of the hole fits into the pivot to hold it in position. Some models have a studded mount pad for a fuel pump on the 1-3 side of crankcase.

3-7. CRANKSHAFTS

Each type of crankshaft is machined from a single forging. The four crankpins are spaced 1800 apart. Starting at the rear and proceeding forward, the crankpin numbers are 1, 2, 3 and 4, according to the cylinders which they serve. Each crankshaft has three main journals, the front one being immediately ahead of No.4 front crankcheek. The cheek is ground flat around the journal and contacts the rear crankcase thrust washer to transfer propeller thrust. A small anti-thrust flange at the front end of the front journal acts as an oil slinger.

CAUTION

This design should not be used in pusher installations.

Older types of shaft had a taper on the front side of the slinger flange. These cannot be installed in present type crankcases because of interference between the taper and the case oil baffle. The slinger flange of present type crankshafts has parallel sides. All crankshafts are center bored for lightness. The front bore runs out at the front crankcheek and the rear end bore at the rear crankcheek. Steel oil tubes are permanently installed in holes drilled from the front and rear journals through crankcheeks to Nos. 1 and 4 crankpins. Oil holes are drilled through solid cheeks from the center journal to Nos. 2 and 3 crankpins. The tapered type shaft has a slot along the propeller hub taper for a square key to drive the steel hub used with it. The hub fits tightly on the taper and is retained by a tube nut, which is locked by a flat head pin. A snap ring in a hub groove ahead of the nut flange acts as a hub puller. The propeller is clamped between the steel hub flange and a loose steel flange in front by six bolts and nuts. The flange type shaft has a propeller mount flange forged on its front end with six tapped bushings pressed into holes spaced equally around the flange. Six bolts, screwed into the shaft flange bushings, clamp the propeller between a loose front flange and the shaft flange. The loose front flange and the six bolts are not supplied as part of the O-200 engine. A steel cased oil seal is installed over the front end of tapered shafts and is retained in the crankcase recess around the shaft opening. With flange type crankshafts a split, composition seal is used. It is made in one piece, and the seal lip is held against the shaft race by a spring. The gear pilot flange at the rear end of the crankshaft has four unequally spaced tapped holes for gear retaining screws. Current production shafts have a dowel between two of the screw holes.

3-8. NITRIDED CRANKSHAFTS

Latest types of flanged and tapered crankshafts have nitrided main journals and crankpins. Flange shafts for C90 and O-200 models have always been nitrided. These are identified by a 1/4 inch hole drilled through the propeller mount flange. Nitrided flange type shafts for C75 and C85

models are identified by the letter "N" stamped on the edge of the propeller flange. Tapered shafts for C75 and C85 models, if not nitrided, have four hub nut lock pin holes at the front end. One additional hole is drilled to identify nitrided shafts.

3-9. CRANKSHAFT GEARS

The gear is piloted on the small rear flange of the crankshaft and aligned by the crankshaft dowel. It is retained by four screws. Screw holes are unequally spaced to assure correct installation. The space between two adjacent punch marked gear teeth points to the camshaft when No.1 crankpin is at T. D. C. Gears for -8 models are plain spur gears. In -12, -16 and O-200 models a cluster gear is installed. Its large wheel has beveled teeth and is driven by the starter pinion.

3-10. CONNECTING RODS

Connecting rod assemblies of C90 and O-200 models differ in dimensions from those of C75 and C85 models, but the two types are of similar design. The rod and bearing cap assembly are made from a single steel alloy forging, which is sawed through the center of the big end before the bearing seat is bored. Each half of the split big end bore is notched to accept the tang of the semicircular bearing insert which fits in it. The replaceable crankpin bearing inserts are thin steel-back shell type, lined with special alloy metal. The bearing cap is attached to the rod by two special bolts and hex nuts. The cylinder number is stamped on the upper bolt boss of both rod and cap. A tapered "I" beam connects the big end and the piston pin boss. The piston pin bushing is a plain bronze sleeve, pressed into the rod boss and bored parallel to the big end bearing. The original type solid piston pin bushing has been replaced by a single piece, split type bushing in both C75, C85, C90 and O-200 type rods.

3-11. CAMSHAFTS

All camshafts installed in C75 and C85 models are flame hardened iron castings. The same material was employed in early production C90 camshafts. Present type C90 and the original O-200 camshafts are alloy steel forgings. These are identified, when new, by an over-all black Parko-Lubrite coating and an underlying copper plate on unfinished surfaces. All C90 and O-200 camshafts are reduced in diameter between cam lobes to provide connecting rod clearance. Standard camshafts for C series carburetor

engines have an eccentric machined at the front fuel pump lever. A special camshaft with two eccentrics is available for installations which require a second fuel pump. Camshafts installed with vacuum pump equipment in -16 and O-200 engines have no pump drive eccentric. The front end of this type has six tapped holes for screws which attach the vacuum pump drive bevel gear. A special combination gear and eccentric is also available for the vacuum pump and side mounted fuel pump. The C90-16 and O-200 also have a camshaft for a side mounted fuel pump with no provision for a vacuum drive gear. The gear is spaced from the shaft end, for correct backlash with the vacuum pump gear, by one or more shims, which are available in two thicknesses. A few of the early production O-200 engines have these shims installed. Current production engines do not require these shims to provide proper backlash. All camshafts have three journals. The center journal is plain, while the front journal has a deep groove to register with oil holes drilled from its bearing into the main oil galleries. The rear journal has flanges at its front and rear ends to restrict camshaft end movement in the rear bearing. The rear flange has four unequally spaced tapped holes for the camshaft drive gear retaining screws. Three cam lobes between each two journals operate valve lifters for two cylinders. In each group, the outer lobes each operate one exhaust valve lifter, and the center lobe operates two opposite intake valve lifters. Lobes of O-200 camshafts have a greater lift than others.

3-12. CAMSHAFT GEARS

Camshaft drive gears installed in -8 models are single spur gears with the web at the rear, while those in -12, -14, -16 and O-200 models have both external and internal teeth, and the web is at the front. The internal teeth drive the generator gear. Both types of gears have a square hole in the center to receive the oil pump driving impeller shaft. A ground recess in the front side of each gear web fits closely over the camshaft pilot flange. The gear is retained by four hex head screws in holes spaced unequally around the web. Thus, the gear can be installed in only one position in relation to the cam lobes. A punch marked tooth is meshed, at assembly, between two similarly marked teeth on the crankshaft gear, and this simple operation assures correct valve timing without measurement.

3-13. HYDRAULIC VALVE LIFTERS

3-14. CONSTRUCTION

Each lifter assembly is composed of an outer body, a hydraulic unit and a pushrod socket. These parts are illustrated in Figure 8. The cam follower is part of the lifter body. The shank of the body is encircled by two oil grooves, which are connected by a flat area. Two holes are drilled through the shank wall in the flat. The hydraulic unit rests against a shoulder in the body. It is composed of a cylinder and a plunger and expanding spring assembly. An inlet tube at the inner end of the cylinder is closed by a ball check valve inside the cylinder. The pushrod socket rests on the head of the hydraulic unit plunger. Its flat base has an oil groove across the center. A hole is drilled from the groove to the socket surface.

3-15. TYPES

Valve lifters installed with cast iron camshafts have steel cam follower faces. Those installed with forged steel camshafts have cast iron cam followers. It is necessary that the dissimilarity of contacting metals be maintained when replacements are made. Valve lifters installed in C90 and O-200 models have 1-1/4 inch diameter cam followers, as required by the cam lobe design. Cam followers of other lifters are 1 inch in diameter.

3-16. OPERATION

Rotation of the lifter is assured by a small taper on the toe line of the cam lobe. This prevents wearing of a groove in the cam follower face. At the outer end of the lifter stroke the outer encircling groove in the shank registers with the crankcase oil supply hole, and engine lubricating oil is forced into the groove, to the flat area and through the two holes in the shank wall. Oil entering the outer hole fills the space surrounding the plunger head, and the intermittent supply flows through the pushrod socket passage and into the hollow pushrod. Oil which enters the inner hole in the shank wall replenishes the reservoir supply. This inlet is indicated in Figure 8 by the letter "H". whenever the valve in the engine cylinder is closed, the cam follower (a) is in contact with the heel of the cam lobe, as shown in Figure 8. Since there is no inward force on the pushrod, the plunger spring (K) holds the plunger (C) and the socket outward against the pushrod end and the hydraulic unit cylinder and lifter body inward, keeping the cam follower against the cam lobe. This expanding action takes up any increase in effective length of the valve linkage due to expansion of the engine cylinder. It also compensates for any wear in linkage parts. Such expansion in the

hydraulic unit increases the volume of the lash adjusting chamber (L) and causes a negative pressure within it. With no inward pressure exerted on it, the check valve ball (D) leaves its seat, allowing oil to flow from reservoir (J) to keep chamber (L) filled. Since engine oil is not supplied to reservoir (J) during this period, the reservoir pressure is reduced by the small loss of oil, thus preventing any "pumping up" of the hydraulic unit. As the cam rotates and lifts the follower, the hydraulic unit is forced outward with the lifter body. The force required to open the engine cylinder valve is transmitted to the pushrod, through the free sliding socket, by plunger (C), creating a high pressure chamber (L) and forcing the check ball (D) on its seat. The plunger (C) is carried outward on the column of oil confined in chamber (L). The pressure causes a "leak-down" of oil around the plunger at a rate controlled by selection of hydraulic unit cylinders and plungers to maintain their diametrical clearance within very close limits. The leak-down permits contraction of the valve linkage when the engine cylinder shrinks with a reduction in temperature. Each time the engine valve closes the small loss of oil from chamber (L) is replaced and any linkage expansion compensated by a flow from the reservoir (J). Thus, zero lash is maintained under all standing and operating conditions, thereby eliminating the necessity of valve clearance and manual adjustments. Hydraulic lifters are designed to operate correctly when the valve linkage clearance, as measured with the hydraulic unit completely deflated, is .030-.110 inch.

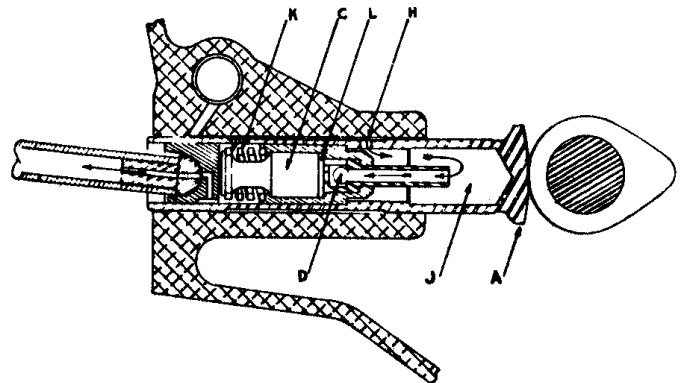

Figure 8. Section Through Hydraulic Valve Lifter.

3-17. PUSHRODS AND HOUSINGS.

Each pushrod is made by pressing a hardened steel ball end into each end of a steel tube. Ball ends are drilled through on the tube axis for oil passage. Each pushrod is surrounded by a thin, tubular steel housing, two of which are permanently installed in

the downward extension of each cylinder rocker box. A cast aluminum adapter, attached to the crankcase by three studs and nuts, is located below each cylinder. Two pushrod housings are sealed to each adapter by rubber connections and hose clamps.

3-18. PISTON ASSEMBLIES

The solid trunk, flat head pistons are machined aluminum alloy castings. Those in C7S and C8S models have four ring grooves above the pin, while C90 and O-200 pistons have three rings above the pin and one below. The upper three compression rings are similar in both types of piston. The top ring is faced with hard chrome to withstand heat. The second and third are plain cast iron rings. The faces of all these are tapered inward toward the top so that wear and seating begin at the bottom, providing good scraping action and quick seal. Center slotted oil control rings in the bottom grooves are slightly different in the two types of piston assembly. Piston pins are seamless steel tubes, ground on the outside and fitted with aluminum end plugs to space them from the cylinder walls. Original type pin assemblies had removable end plugs. End plugs of current production pins are pressed in before final grinding and are not replaceable. This type of pin assembly must be used for all replacements. Pins are a push fit in piston bores.

3-19. CYLINDER ASSEMBLIES

3-20. CYLINDER AND HEAD

Externally finned aluminum alloy head castings are screwed and shrunk permanently on externally finned steel barrels. The rocker box cast in the outer end of the head has a surrounding flange which is machined flat. The pressed steel rocker cover is sealed to the flange by a soft gasket and retained by six fillister head screws. Three bosses cast in the rocker box are bored in a horizontal line at right angles to the cylinder axis to form rocker shaft supports. Valve ports in the head open downward into two flanges, each provided with two studs. Bronze guides for intake and exhaust valves are pressed into holes bored from the bottom of the rocker box into the valve chambers in line with the valve seats. Alloy steel exhaust valve seat inserts and aluminum bronze intake valve seat inserts are shrunk into counterbores in the combustion chamber surface. Early production cylinders had

threaded spark plug inserts screwed and pinned in tapped holes above and below the valve seats.

CAUTION

Use original piston with original cylinder or replace spark plug bushing with helicoil when using current piston in original cylinder.

Current production cylinders incorporate helical coil type inserts. A 1/8 inch pipe tapped hole through the upper wall of the intake valve chamber of earlier production cylinders is intended for a primer jet, which may be installed by the owner. The hole is normally sealed by a countersunk hex head pipe plug. An external base flange below the cylinder barrel fins is ground flat and drilled for the six crankcase studs, to which the assembly is attached by flanged hex nuts. From the base flange, the cylinder skirt extends inward through the crankcase wall opening, as a pilot. A rubber packing ring, placed around the cylinder skirt and against the flange, is compressed in a chamfer around the pad opening and prevents oil leakage. Two tubular steel pushrod housings are swelled into holes in the downward extension of the rocker box and lie below the cylinder.

3-21. VALVES

Both intake and exhaust valves are a modified tulip design. The head of the intake valve is marked "IN", and the exhaust valve head is marked "EX". The tip of each valve stem is hardened and ground flat and square with the stem surface. Near the tip, a groove is cut in the stem to engage the split lock. The face of the exhaust valve has a 3/64 inch minimum thickness of No.6 Stellite welded on to withstand heat.

3-22. VALVE SPRINGS

An inner valve spring retainer of pressed steel is installed over each valve guide and seated on the rocker box bottom to center the valve springs and prevent wear on the aluminum head surface. One inner and one outer spring fit in each retainer, surrounding the valve stem. They are retained by outer spring seat of steel, whose conical center hole fits over the valve stem and is engaged to it by the split locks. Each valve in C90 and O-200 cylinders has three springs.

3-23. ROCKER ARMS AND SHAFT

Two rocker arm assemblies are pivoted on a tubular steel shaft, which is ground on its outer surface to a push fit in the cylinder head support bores. The rocker is a steel forging with a bronze bushing. A pushrod socket is machined in the lower end. The valve contact surface, at the upper end, is hardened and ground to an arc. A small oil hole, drilled from the center of the pushrod socket, intersects a hole drilled upward and through the bushing wall. A groove around the bushing's inner surface carries the oil channel to a second vertical hole, which ends in a squirt nozzle facing the valve stem. An orifice in the valve stem end of the exhaust valve rocker arm provides lubrication to the exhaust valve stem during engine operation.

3-24. TYPES

Cylinder heads installed in early production C90

models were hand polished to eliminate roughness in the intake passage and to assure full air flow to the combustion chambers. Later improvement in smoothness of the head castings made the hand polishing operation unnecessary, and current production cylinder and head assemblies are identical in all models. Any cylinder and head assembly with a smooth air intake passage may be installed on C90 models. Older assemblies with any roughness in the passage must be used only on C75 and C85 models. Outer and inner valve springs are installed in cylinder assemblies of models C75 and C85. Outer, intermediate and inner valve springs are installed in cylinder assemblies of model C90 and O-200. The latter type cylinders have the additional spring on each valve because of the greater valve lift obtained with the C90 and O-200 camshafts. For details of valve springs in each model engine, refer to the Spring Pressures Chart in the Table of Limits, Section XVIII.

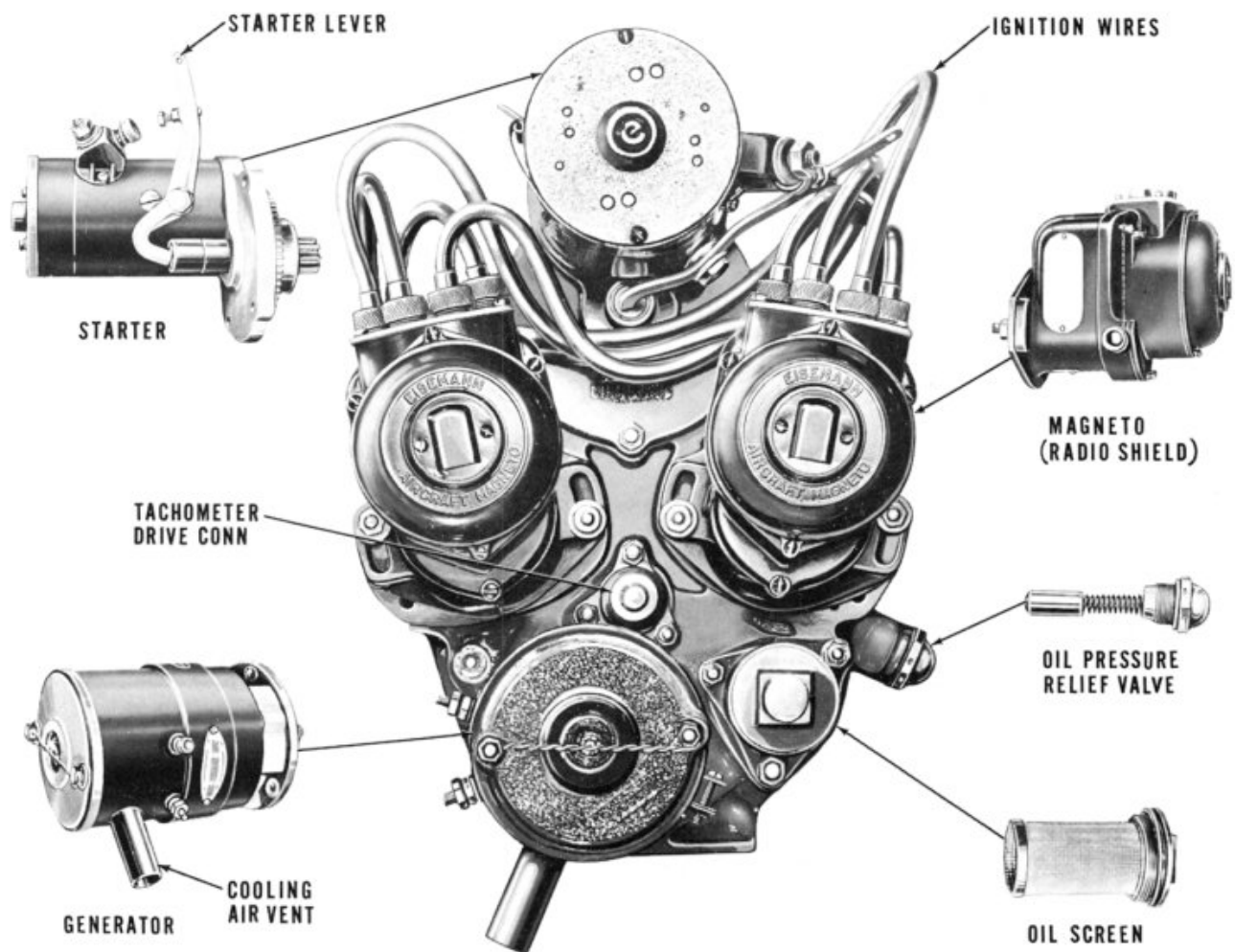

Figure 9. Crankcase Cover and Accessories of -12, -14, -16 and O-200 Models

3-25. CRANKCASE COVER ASSEMBLY FOR -12, -14, -16 AND O-200 MODELS

The magnesium cover casting is 2-3/8 inches deep. Accessory mount pads on the rear surface are all machined in one plane parallel to the machined parting flange which surrounds the front side of the casting. Locations of the pads and methods of accessory attachment are illustrated in Figure 9. Two holes, drilled through the casting at the top, are for the bolts which attach the starter adapter to the crankcase rear flange. Central openings in magneto mount pads admit the magneto drive gears and locate the magneto pilot shoulders. The tachometer drive housing is attached by three studs and nuts over a gasket which also covers the generator mount pad. The tachometer drive shaft is the slotted rear end of the oil pump driven impeller shaft. The tachometer drive housing has an external thread for the drive conduit nut. A steel cased oil seal is pressed into the front end of the housing. Its seal lip contacts the tachometer drive shaft ahead of the slot. Below the tachometer drive shaft hole, a second bearing is bored through the cover rear wall for the oil pump driving impeller shaft. The oil pump impeller chambers are machined in the front side of the cover rear wall in line with the shaft holes. An aluminum cover is attached over the open front end of the pump chambers by four screws. The squared front end of the driving impeller shaft projects forward through the pump cover to engage the square hole in the center of the camshaft gear. The generator mount pad has two short studs and a hole for one of the crankcase studs. The generator is attached to these three studs by elastic stop nuts. The gear opening is counterbored to fit the generator pilot shoulder. The oil screen housing is attached, over a triangular gasket, by nuts installed on a short stud, driven into the pad, and two long crankcase studs, which project through holes in the cover. The bottom of the cover casting is a semicircle, open at the front, with a surrounding flange, which is machined and studded to finish the rear half of the oil sump mount pad. The oil pump suction tube is screwed into the bottom cover wall within the semicircle and is sealed by a copper-asbestos gasket. A screen is permanently attached over the lower tube end, which lies below the sump oil level. A cored passage in the cover casting extends from the upper end of the suction tube to the oil pump inlet. From the delivery port of the

pump, a second cored passage extends to the right and surrounds the oil screen opening. The screen cap is screwed into the screen housing over a copper-asbestos gasket. The oil screen is permanently attached to the cap and is reinforced by a ferrule at its open front end. The ferrule fits closely in a hole bored in the front wall of the oil passage. From the screen outlet, another passage in the cover leads to a hole drilled in the cover parting flange in register with the crankcase oil inlet. In line with the crankcase right oil gallery, a hole is drilled from the cover casting parting flange rearward. An intersecting hole to the right ends in an open cavity within the hollow boss for the oil pressure relief valve. The valve plunger seats on the end of the drilled hole. It is guided in a bronze cap, which is screwed into the boss, and is held on its seat by a spring. A drilled and tapped hole on the left side of the O-200 crankcase cover ends in the cored passage on the suction side of the oil pump and provides an oil return from the vacuum pump.

3-26. CRANKCASE COVER ASSEMBLY FOR -8 MODELS

The magnesium cover casting is 1-5/32 inches deep at the magneto mount pads, while the integral oil screen housing, at the left side, extends 3-11/16 inches from the parting flange, and the central boss for the tachometer drive housing extends 3-3/8 inches. The bottom of the casting is similar to that of the cover to -12 models, and the oil pump suction tube is attached in the same manner. Cored passages connect the suction tube to the oil pump inlet and the pump outlet to the oil screen cavity. The squared front end of the oil pump driving impeller extends through the pump cover and into the square hole in the camshaft gear. The rear end of the driving impeller is the tachometer drive shaft. The tachometer drive housing is screwed into a left hand thread in the cover boss. An oil seal pressed into the front of the housing rides on the tachometer drive shaft. The oil screen and pressure relief valve assemblies are the same as installed in -12, -14, -16 and O-200 models. The cover passage from the screen leads to the left oil gallery. The pressure relief valve closes the rear end of a hole drilled from the cover flange, in line with the right oil gallery, to the gear cavity.

3-27. GEAR TRAIN (See Figure 10)

Courtesy of Bomar Flying Service
www.bomar.biz

The crankshaft gear (1) is rotated in a clockwise direction by the crankshaft. The small gear section of the crankshaft gear mates with and drives, at 1/2 crankshaft speed, the camshaft gear (2). For -8 models the crankshaft gear also drives the magneto gears direct in a counterclockwise direction. The magneto gears (3), oil pump driver gear (4) and generator drive gear (6), of -12, -14, -16 and O-200 are driven by the camshaft gear. The tachometer shaft, in the -8 model, is driven by the oil pump drive impeller shaft, while in the -12, -14, -16 and O-200 models it is driven by the pump driven impeller shaft. Starting power is transmitted to the crankshaft by the starting motor pinion (7) engaging the large gear section of the crankshaft gear on -12, -14, -16 and O-200 models.

3-28. CARBURETOR INDUCTION SYSTEM

The intake manifold is attached to two long studs in the crankcase lower flange. The carburetor is attached to a studded square flange on the bottom of the manifold. The air passage through the manifold divides into four horizontal outlets, to which the cylinder intake tubes are sealed by rubber hose connectors and clamps. The intake tubes are connected by the same means to cast aluminum elbows, attached to the studded cylinder intake port flanges. The air intake housing is attached to the studded carburetor bottom flange. The flat sheet metal housing flares upward at its front end to match the square air filter. The filter is fastened to the housing front flange by four slotted head studs, which may be released by a quarter turn. A sheet metal bracket ties the front end of the intake housing to the manifold. A lever-operated plate valve in the intake housing opens and closes a hot air inlet to the manifold. A collar at the right rear corner of the housing attaches the hot air supply tube. A fuel drain tube is welded to the bottom of the intake housing.

3-29. OIL SUMPS

The sump body is a welded assembly composed of front and rear halves of pressed sheet steel. A thick mounting flange ring, four brackets, an oil fill neck and a drain plug boss are welded to the body to complete the assembly. The location and length of the oil fill neck vary to suit the aircraft installation. A bracket is welded to the neck for support by attachment to a stud in the lower crankcase mounting arm. The tubular steel neck has a bayonet

locking device at the outer end for quick attachment of the gauge cap. The sump drain boss is tapped for a 5/8-18 plug, which is sealed by a copper-asbestos gasket. The mount flange ring is drilled for the six attaching studs in the crankcase and cover pad. The oil gauge rod is graduated in quarts to the "FULL" mark. At present, sumps are attached with elastic stop nuts to undrilled case studs.

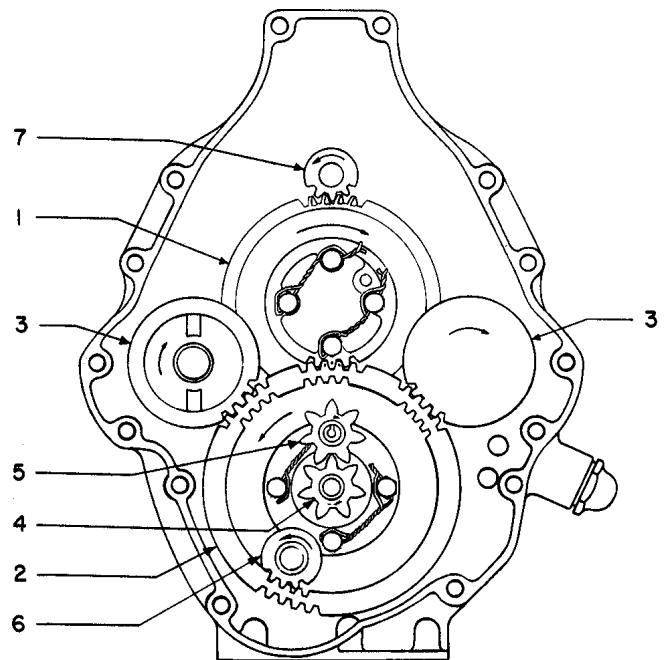

1. Crankshaft gear
2. Camshaft gear
3. Magneto drive gears
4. Oil pump driving impeller
5. Oil pump driven impeller
6. Generator drive gear
7. Starter Pinion

Figure 10. Gear Train of -12, -14, -16 and O-200 Models

3-30. IGNITION SYSTEM

3-31. UNSHIELDED

Unshielded ignition cables and unshielded spark plugs are standard equipment of all C7S, C8S and C90 models. Individual cables connect all upper plugs to the high tension terminals of the right magneto, and all lower plugs are connected to terminals of the left magneto. Unshielded ignition cables are of conventional construction, with high tension insulation over 19 strand copper conductors. Each cable assembly is attached to a spark plug by a

safety lock terminal and has a magneto end terminal of the type required by the magneto installed. Four plate brackets, attached to crankcase studs, support each pair of upper cables and each pair of lower cables near the cylinder bases. Two similar brackets, attached by magneto retaining nuts of -8 models and by crankcase cover retaining nuts of -12 models, support four ignition cables on each side of the engine. A rubber grommet in each bracket prevents chafing of the cable insulation. C90-8 models are equipped with Bendix S4RN-21 magnetos, and all C90-12, -14 and O-200 models have Bendix S4LN-21 or slick Series 4000 magnetos. C75, C85 models may also have Bendix magnetos. For this type of magneto, all four cables are attached by cable piercing screws to a removable terminal plate and grommet assembly, making a single cable assembly for each magneto.

3-32. RADIO SHIELDED IGNITION SYSTEMS

Either Eisemann LA-4, Bendix S4LN-20 or slick Series 4000 magnetos may be used with shielded system where approved. (See Table IX). Radio shielded ignition cables are assembled in pairs for the upper right, upper left, lower right and lower left spark plugs. The brackets which hold together the two cables in each assembly are attached to crankcase studs. A wrapping of friction tape prevents the old style bracket from cutting or chafing cable insulation. New brackets are neoprene coated to prevent cutting or chafing. Cable assemblies for -8 and -12 models with LA-4 magnetos have only one bracket each. An additional bracket is installed on the bottom starter retaining stud to hold upper left and lower right spark plug cables away from the starter clutch shaft. Shielded cable assemblies for Bendix magnetos of -8 models have one bracket on each pair of cables, and for -12 models they have a second bracket on each pair. The two pairs of cables served by each magneto are attached to the terminal plate grommet by cable piercing screws. All shielded cables are equipped with spark plug elbows and contact sleeves. To make contact with other shielding members, the outer plastic wrap of the cable is stripped for a short distance at each end, and the sheath of braided copper wires is folded back to make a cuff. At the spark plug end a split lead cone is placed over the cuff and held in the elbow by a union nut. At the magneto end a flanged

ferrule is swaged on over the cuff and is held to the magneto terminal plate by a coupling nut.

3-33. SWITCH WIRE TERMINALS

The AM-4 magneto has a stud terminal, to which the switch wire is attached by a hex nut. Shielded magnetos have spring terminals within the breaker housing, and switch wires must be equipped with terminal assemblies consisting of contact, insulators, ferrules and union nut. Wire terminal assemblies are furnished with LA-4 magnetos, Bendix terminal kits are sold separately and are slightly different.

3-34. MAGNETO DRIVE GEARS

Eisemann AM-4 magnetos installed on the left side of C85-8 models have impulse couplings, but those on the right side are driven by a gear mounted directly on the rotor shaft. All Eisemann LA-4 Bendix S4N, and Slick magnetos have impulse couplings. Drive gears for these magnetos are centered on a sleeve on the rotor shaft, and they are retained by a nut screwed on the shaft, but they are free to rotate on the shaft, but they are free to rotate on the sleeve. They drive the impulse coupling barrel lugs, which fit in slots in the gear web. The type of gear installed with impulse couplings on -12, -14, -16 and O-200 models extends further forward than the type installed on -8 models, due to the difference in crankcase cover depth.

3-35. IMPULSE COUPLING OPERATION

The impulse coupling performs two important operations to facilitate starting, i.e., it holds back the magneto rotor, just before the breaker opening position, while the drive gear continues its rotation, thereby retarding the spark, and it releases the rotor approximately at T. D. C. of the engine piston, allowing the coupling spring to spin the rotor rapidly through its neutral position, opening the breaker and producing a hot spark at cranking speed. Two counterweighted latches in the coupling flange assembly provide the automatic spark retard. The upper latch engages a stud in the housing and stops rotation of the flange and rotor shaft. Further rotation of the barrel (or drive cup) winds up the coupling spring until the barrel contacts the latch and forces it inward and clear of the stud. Then, the spring spins the flange and rotor through neutral to produce the spark. After the engine starts, the latch

counterweights hold the latch pawls away from the stud, and the coupling spring drives the rotor in the full advance position.

3-36. DELCO-REMY STARTER

The motor and clutch of the direct cranking starter are mounted on an adapter plate, by which the unit is attached to crankcase cover studs and through bolts. The clutch and pinion assembly bears in a Oilite bushing, pressed in a hole bored through the adapter below the motor. Another Oilite bushing in the hollow clutch shaft bears on the pivot held in the crankcase. A large gear on the clutch shaft is driven by the armature shaft gear. The pinion is driven by the clutch shaft through an over-riding clutch. A spring in the front end of the clutch shaft is slightly compressed by the pivot, tending to disengage the starter pinion. A lever, pivoted on the motor coil housing and operated by a cable from the cockpit, shifts the clutch shaft forward, for starting, and the pinion meshes with the teeth of the large wheel on the crankshaft cluster gear. The starter switch button is depressed, to close the electrical circuit, by the shift lever. The shift lever operates the clutch through a spring cap and spring in the rear end of the clutch shaft, so that the clutch can be closed, even though the pinion and cluster gear teeth are abutted. Immediately the motor turns, the pinion meshes.

3-37. PRESTO LITE STARTER

The Prestolite Starter is solenoid actuated and employs a Formsprag Torque Limiting Drive which is used with, but is not part of, the starter. The clutch assembly bears in a needle bearing pressed in a hole bored through the adapter below the motor. The other end rides in a needle bearing pressed into the starter jackshaft adapter located in the crankcase. As the solenoid is actuated, by the key or switch, the starter gear turns engaging a gearshaft which activates a sprag pack in the clutch assembly. The sprag pack expands and drives the hub, which drives the idler gear and thereby the crankshaft gear. When the engine fires and the crank is running at a greater speed than the starter, the sprag pack is no longer driving the hub.

3-38. GENERATOR/ALTERNATOR AND DRIVE

The Delco-Remy generators have specific amperes output at 12 volts. It is attached to the three case

studs by elastic stop nuts; A vent tube connection is built on the brush cover, which may be rotated. An oil seal is pressed into a counter bore around the shaft hole at the front of the drive end frame, contacts the rear shoulder of the coupling hub. The hub has a slot for the woodruff key installed in the shaft. The rubber drive disc and its pressed steel retainer fit into a slot in the front side of the hub. Two lugs on the drive gear fit into a front slot in the rubber disc. Gear torque is transmitted through the lugs to the disc. The flat sides of the disc and steel retainer transmit the torque to the slotted hub, which drives the generator shaft through the woodruff key. A steel sleeve passes through the gear, rubber disc and retainer and presses the hub against the shaft shoulder. A nut is tightened on the shaft thread against the sleeve, but the gear is free. In the latest type of drive the rubber disc is replaced by two rubber bushings, which fit between the flat sides of the retainer and the gear lugs. The drive lugs of the gear used in this drive extend through the entire thickness of the bushings, but clear the retainer.

3-39. SIDE MOUNTED FUEL PUMP

This optional equipment consists of an AC diaphragm pump, which may be obtained with the inlet port at either front or rear, inlet and outlet elbow fittings, a delivery tube assembly and a carburetor inlet elbow. The pump is installed, with the fuel dome upward, on a pad at the front of the crankcase right side. The pump lever extends through the pad opening into the crankcase and rests on top of the camshaft eccentric. Rotation of the eccentric operates the lever to produce the pumping action. The inlet elbow is connected to the aircraft fuel supply line. The pump delivery tube is connected to the pump outlet elbow and to the carburetor inlet elbow by union nuts. Check valves in the pump allow fuel to flow only toward the carburetor.

3-40. DUAL FUEL PUMP EQUIPMENT

When the aircraft installation requires two fuel pumps, a second diaphragm pump is installed on the rear side of a special adapter, which is attached to the mount pad of early models. This adapter can be installed only on crankcases of which the vacuum pump pad is machined and studded. A vertical pushrod, guided in the adapter, is depressed by the rear eccentric of the special camshaft which must be

installed with the dual pump equipment. The front of this camshaft operates the side pump lever. The pushrod transfers the eccentric motion to the lower pump operating lever. Both pump inlets are connected to the aircraft supply line. A nipple is screwed into the lower pump outlet, and a cross fitting is screwed onto the nipple. The delivery tube from the side pump is connected to the cross. Thus, the cross receives the output of both pumps. A tube delivers the combined output from the cross the carburetor inlet. The fourth branch of the cross is plugged. A sediment bowl is incorporated in the lower pump. A special bracket, attached to the lower pump adapter by one of the pump retaining nuts, supports the carburetor air intake housing when this equipment is installed. Oil, fed to the lower pump adapter to lubricate the pushrod guide, is drained through a tube from the adapter to a tapped boss on the special oil sump.

3-41. LUBRICATION SYSTEM

3-42. OIL CIRCULATION IN -8 MODELS

Oil rises, under atmospheric pressure, from the sump supply through the suction tube to fill the volume displaced by the pump. The oil is carried around the chambers between impeller teeth and is forced from the pump outlet port through the crankshaft cover passage to the cavity surrounding the oil screen. As the oil flows through the screen mesh, any foreign particles are deposited on the exterior. The strained oil flows from the open front end of the screen, through a short cored passage, and into the rear end of the left oil gallery. The oil stream flows forward through the left gallery, across the crankcase, through the passages connected by the camshaft front journal groove, and into the right gallery. The oil pressure relief valve closes the rear end of the right gallery until delivery of the pump creates a pressure above the normal range of 30 to 35 psi. Excessive pressure opens the valve, allowing oil to drain into the crankcase rear cover, until the pressure again drops to normal. Three oil ducts, drilled from crankshaft main bearings to the left oil gallery, conduct a portion of the oil stream to these bearings. Other drilled holes conduct a portion of the oil to the camshaft bearings. Part of the main bearing supply flows through crankcheek passages to the crankpins. The oil film formed in all of these bearings is continually replenished, and oil is forced to spray from their ends, filling the case with a mist.

Oil sprayed into the cylinders is scraped back into the case by piston rings. Piston pins and cylinder walls are lubricated and cooled by the spray. Gears in the crankcase cover cavity are lubricated by spray from rear main and rear camshaft bearings. Valve lifters are supplied with oil, as described in paragraph 3-16 and shown in figure 8. From the lifter sockets, oil flows through the hollow pushrods to the rocker arm passages described in paragraph 3-23, to lubricate the rocker bushings and the valve stems. Oil sprayed into the rocker boxes drains back to the crankcase through the pushrod housings. All the oil returned to the crankcase and the portion which is sprayed into the rear cover drains back to the sump through the open center of the sump mount flange.

3-43. OIL CIRCULATION IN -12, -14, -16 AND O-200 MODELS

The oil flow path in -12, -14, -16 and O-200 models is the same as in -8 models, except in the following details. The pump delivers oil to the screen on the right side of the crankcase cover. The screen outlet is registered with a drilled hole in the crankcase below the right oil gallery. An intersecting hole is drilled across to the left of the crankcase, emerging at the oil cooler mount pad above the left oil gallery. If no cooler is installed a pad cover passage conducts the oil stream down to a second hole in the side of the case and into the left oil gallery. In addition to the details mentioned above, the -16 and O-200 crankcase has an oil passage drilled from the vacuum pump adapter mount pad into the left crankcase cross passage. The vacuum pump adapter inlet registers with the drilled hole in the left crankcase and directs the oil stream through the adapter to the vacuum pump mounting pad. An intersecting hole is drilled from the adapter oil outlet to provide pressure lubrication to the adapter bushing. Oil drainage from the bushing is returned to the crankcase cavity through two oil passages just above the oil seal seat. Whenever a vacuum pump is installed, it will be necessary to provide an external oil return line to direct the oil from the pump to the tapped hole in the crankcase cover.

3-44. OIL COOLER EQUIPMENT

The cooler adapter, an aluminum casting, is attached by two case studs over the pad behind No.2 cylinder, described in paragraph 3-42. The oil stream from the pump enters the adapter inlet port,

passes through the adapter into the cooler, which is attached to the adapter by three studs and nuts, flows through the cooler core and returns to the adapter outlet passage. The adapter outlet port delivers the oil stream to the crankcase inlet hole leading to the left oil gallery. A spring loaded ball valve closes a by-pass in the adapter between the inlet and outlet passages. In the event of radiator core stoppage, the increased pump delivery pressure caused by the restriction, opens the by-pass valve, allowing the oil to by-pass the cooler and return to the crankcase inlet.

The by-pass valve also permits cold, viscous oil to by-pass until its pressure is reduced by increased temperature. This equipment can be installed only on -12, -14, -16 and O-200 models.

SECTION IV

UNPACKING THE ENGINE

4-1. SHIPPING CRATES

The side and top panel assembly of the domestic shipping crate is attached to the wood base and engine cradle assembly by nails. The plywood cradle is bolted to the base. Skids under the base platform permit a rope or cable to be passed under the crate to make a lifting sling. The export shipping crate is composed of a heavy wood base assembly and a wood side and top panel assembly, which is lined with waterproof paper. The side panels are nailed to the base. A wood clamp block secures the crankshaft to a base bolster, and two steel angle members, bolted to a parallel bolster, support the crankcase upper mounting arms.

CAUTION

Do not lift domestic shipping crates by attachment of the lifting sling to sides or top. All lifting force must be applied directly to the base.

4-2. METHOD OF PACKING AND PRESERVATION

Before the engine is stopped, after completion of the factory test, a corrosion-preventive mixture is fed into the lubrication system and sprayed into the air intake. During the packing operation, the same mixture is sprayed into spark plug holes. All openings are closed to exclude moisture. Engines are supported in shipping crates in the inverted position. Carburetor air intake assemblies, air filters and other installation equipment parts are fastened securely to the engine. Propeller hubs, if used, are fastened to the crate base. A moisture proof shroud is placed over the engine to protect it from dripping water.

CAUTION

The factory preservation treatment applied to new and re-manufactured engines will be effective for a period dependent on atmospheric conditions at the point of storage. During prolonged

storage, it is advisable to inspect crated engines at regular intervals of not more than 30 days to determine that internal surfaces are covered with the corrosion-preventive oil. Cylinder walls may be inspected through spark plug holes. Rocker covers may be removed for inspection of rocker box parts. The crankshaft must not be turned during inspection. In very warm or damp climates or in localities where daily temperature variation is large, inspection of stored engines at more frequent intervals is recommended. After inspection, replace all closures.

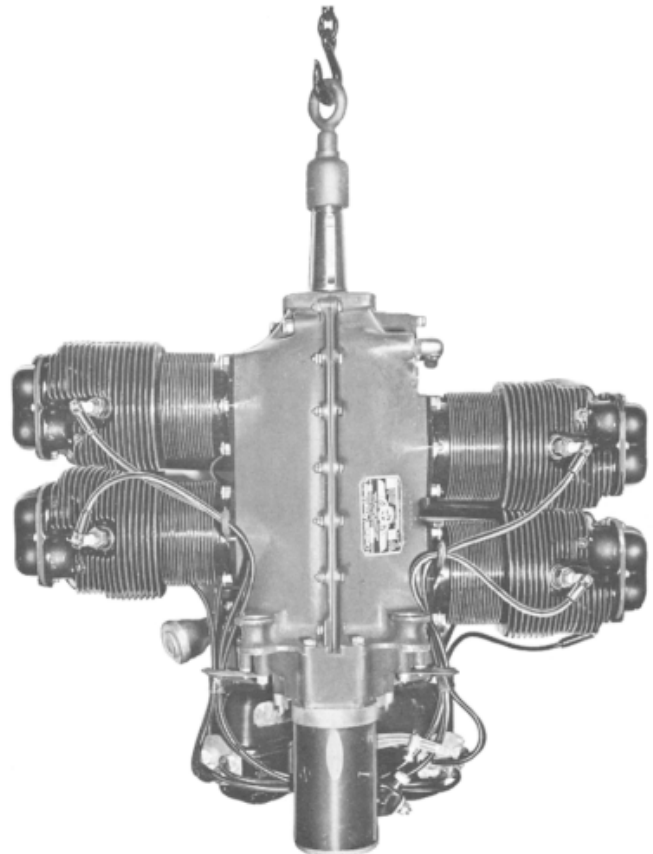

Figure 11. Hoisting Engine by Crankshaft Lifting Eye.

4-3. REMOVAL OF ENGINE FROM CRATE

Remove the crate side and top panel assembly by pulling out the nails which attach the sides of the base. Remove nuts and bolts which secure the upper crankcase mount arms to the domestic crate cradle or to the export crate angle members. Loosen the crankshaft clamp bolts if it is an export crate. If the engine has a flange crankshaft, remove the bolts attaching the propeller flange to the cradle or base bolster. Lift the engine from the cradle, taking care not to pinch or pull ignition cables. Turn the engine to the vertical position; attach a lifting eye to the crankshaft, and take up the engine weight on the hoist, as illustrated in Figure 11. If the engine has a flange type crankshaft a different type of lifting eye will be required. Such an eye can be made locally by bending a length of steel bar stock, at least 3/16 X 1 inch to a horseshoe shape (in the flat), bending the ends in opposite directions to right angles, and drilling holes in the bent ends for 3/8-24 bolts, with which to attach the eye to opposite propeller bolt bushings.

4-4. PREPARATION FOR INSTALLATION

Fasten the engine mounting arms securely to a suitable assembly stand or support which will hold the engine in the vertical position. Detach and remove all loose parts fastened to the engine, and remove closures from the breather elbow, cylinder exhaust ports, carburetor bottom flange and any other sealed openings. If it is a carburetor engine, install the gasket and intake housing on the carburetor bottom flange and attach to the four studs with slotted nuts and lockwire. Bend the intake housing bracket to correct position, and attach to the housing with two drilled fillister head screws, washers and lockwire. Prepare the air filler of any type engine by placing the four slotted head studs through holes in the filter frame from the front side and through the filter gasket, then driving the cross pins through the stud holes. Place the filter and gasket on the intake housing front flange, with the studs entering the cam plates, and turn each stud to the right to lock it, holding filter and stud firmly in place. Install the fuel pump, oil cooler, cylinder baffles and any other engine accessories and attachments required by the aircraft installation.

SECTION V

STORAGE OF ENGINES

5-1. GENERAL

Engines in aircraft that are flown only occasionally tend to exhibit cylinder wall corrosion more than engines in aircraft that are flown frequently.

Of particular concern are new engines or engines with new or freshly honed cylinders after a top or major overhaul. In areas of high humidity, there have been instances where corrosion has been found in such cylinders after an inactive period of only a few days. When cylinders have been operated for approximately 50 hours, the varnish deposited on the cylinder walls offers some protection against corrosion.

Obviously even then proper steps must be taken on engines used infrequently to lessen the possibility of corrosion. This is especially true if the aircraft is based near the sea coast or in areas of high humidity and flown less than once a week.

In all geographical areas the best method of preventing corrosion of the cylinders and other internal parts of the engine is to fly the aircraft at least once a week long enough to reach normal operating temperatures which will vaporize moisture and other by-products of combustion.

Aircraft engine storage recommendations are broken down into the following categories:

Flyable Storage (7 to 30 days) Temporary Storage (up to 90 days) Indefinite Storage

5-2. FLYABLE STORAGE (7 to 30 days)

- a. Service aircraft per normal airframe manufacturer's instructions.
- b. Each seven days during flyable storage, the propeller should be rotated by hand without running the engine. Rotate the engine six revolutions, stop the propeller 450 to 900 from the original position.

For maximum safety, accomplish engine rotation as follows:

- (1) Verify magneto switches are "OFF"
 - (2) Throttle position "CLOSED"
 - (3) Mixture control "IDLE CUT-OFF"
 - (4) Set brakes and block aircraft wheels (5) Leave aircraft tie-downs installed and verify that the cabin door latch is open (6) Do not stand within the arc of the propeller blades while turning the propeller
- c. If at the end of thirty (30) days the aircraft is not removed from storage, the aircraft should be flown for thirty (30) minutes, reaching, but not exceeding, normal oil and cylinder temperatures. If the aircraft cannot be flown it should be represerved in accordance with "B" (Temporary Storage) or "c" (Indefinite Storage).

5-3. TEMPORARY STORAGE (Up to 90 Days)

a. Preparation for Storage

1. Remove the top spark plug and spray atomized preservative oil, (Lubrication Oil-Contact and Volatile Corrosion-Inhibited, MIL-L-46002, Grade 1) at room temperature, through upper spark plug hole of each cylinder with the piston in approximately the bottom dead center position. Rotate crankshaft as each pair of opposite cylinders is sprayed. Stop crankshaft with no piston at top dead center.

NOTE

Shown below are some approved preservative oils recommended for use in Teledyne Continental engines for temporary and indefinite storage:

MIL-L-46002, Grade 1 Oils:

NOX RUST VCI-105

Daubert Chemical Company
4700 S. Central Avenue
Chicago, Illinois

TECTYL 859A

Ashland Oil, Inc.
1401 Winchester Avenue
Ashland, Kentucky

2. Re-spray each cylinder without rotating crank. to thoroughly cover all surfaces of the cylinder interior, move the nozzle or spray gun from the top to the bottom of the cylinder.
 3. Re-install spark plugs.
 4. Apply preservative to engine interior by spraying the above specified oil (approximately two ounces) through the oil filler tube.
 5. Seal all engine openings exposed to the atmosphere using suitable plugs, or moisture resistant tape, and attach red streamers at each point.
 6. Engines, with propellers installed, that are preserved for storage in accordance with this section should have a tag affixed to the propeller in a conspicuous place with the following notation on the tag: "DO NOT TURN PROPELLER ENGINE PRESERVED."
- b. Preparation for Storage
1. Remove seals, tape, paper and streamers from all openings.
 2. With bottom spark plugs removed from the cylinders, hand turn propeller several revolutions to clear excess preservative oil, then re-install spark plugs.
 3. Conduct normal start-up procedure.
 4. Give the aircraft a thorough cleaning and visual inspection. A test flight is recommended.

5-4. INDEFINITE STORAGE

a. Preparation for Storage

1. Drain the engine oil and refill with MIL-C-6529 Type II. Start engine and run until normal oil and cylinder head temperatures are reached. The preferred method would be to fly the aircraft for thirty (30) minutes. Allow engine to cool to ambient temperature. Accomplish steps "5-2.a." and "5-3.a." of temporary storage.

NOTE

MIL-C-6529 Type II may be formulated by thoroughly mixing one part compound MIL-C-6529 Type I (Esso Rust-Ban 628, Cosmoline No. 1223 or equivalent) with three parts new lubricating oil of the grade recommended for service (all at room temperature).

2. Apply preservative to engine interior by spraying MIL-L-46002, Grade 1 oil (approximately two ounces) through the oil filler tube.
- b. Install dehydrator plugs MS27215-2, in each of the top spark plug holes, making sure that each plug is blue in color when installed. Protect and support the spark plug leads with AN -4060 protectors.
- c. If the carburetor is removed from the engine, place a bag of desiccant in the throat of the carburetor air adapter. Seal the adapter with moisture resistant paper and tape or a cover plate.
- d. Place a bag of desiccant in the exhaust pipes and seal the openings with moisture resistant tape.
- e. Seal the cold air inlet to the heater muff with moisture resistant tape to exclude moisture and foreign objects.
- f. Seal the engine breather by inserting a dehydrator MS27215-2 plug in the breather hose and clamping in place.

- g. Attach a red streamer to each place on the engine where bags of desiccant are placed. Either attach red streamers outside of the sealed area with tape or to the inside of the sealed area with safety wire to prevent wicking of moisture into the sealed area.
- h. Engines, with propellers installed, that are preserved for storage in accordance with this section should have each propeller tagged in a conspicuous place with the following notation on the tag: "DO NOT TURN PROPELLER-ENGINE PRESERVED."

As an alternate method of indefinite storage, the aircraft may be serviced in accordance with the procedures under Temporary Storage providing the airplane is run-up at maximum intervals of 90 days and then re-serviced per the temporary storage requirements.

5-5. PROCEDURES NECESSARY FOR RETURNING AN AIRCRAFT TO SERVICE ARE AS FOLLOWS:

- a. Remove the cylinder dehydrator plugs and all paper, tape, desiccant bags, and streamers used to preserve the engine.
- b. Drain the corrosion preventive mixture and re-service with recommended lubricating oil.

WARNING

When returning the aircraft to service do not use the corrosion preventive oil referenced in paragraph 5-4.a.i. for more than 25 hours.

- c. With bottom plugs removed rotate propeller to clear excess preservative oil from cylinders.

- d. Re-install the spark plugs and rotate the propeller by hand through the compression strokes of all the cylinders to check for possible liquid lock. Start the engine in the normal manner.
- e. Give the aircraft a thorough cleaning, visual inspection and test flight per airframe manufacturer's instructions.

5-6. AIRCRAFT STORED IN ACCORDANCE WITH THE INDEFINITE STORAGE PROCEDURES SHOULD BE INSPECTED PER THE FOLLOWING INSTRUCTIONS:

- a. Aircraft prepared for indefinite storage should have the cylinder dehydrator plugs visually inspected every 30 days. The plugs should be changed as soon as their color indicates unsafe conditions of storage. If the dehydrator plugs have changed color in one-half or more of the cylinders, all desiccant material on the engine should be replaced.
- b. The cylinder bores of all engines prepared for indefinite storage should be resprayed with corrosion preventive mixture every six months, or more frequently if bore inspection indicates corrosion has started earlier than six months. Replace all desiccant and dehydrator plugs. Before spraying, the engine should be inspected for corrosion as follows: Inspect the interior of at least one cylinder on each engine through the spark plug hole. If cylinder shows start of rust, spray cylinder corrosion preventive oil and turn prop six times, then respray all cylinders. Remove at least one rocker box cover from each engine and inspect the valve mechanism.

SECTION VI

INSTALLATION IN THE AIRCRAFT AND REMOVAL

6-1. MOUNTING THE ENGINE

It will be assumed that all parts shipped loose with the engine except propeller attaching parts, have been installed and that any aircraft equipment, such as cylinder baffles, has been attached to the assembly. It will be necessary to have an adapter hook which will pass through the engine lifting eye, with a loop of sufficient diameter to admit the hoist hook. Proceed as follows:

- a. If the engine is mounted on a rotating assembly stand, turn the engine to the flight position, and take up the engine weight on the hoist. If the engine rests on a fixed stand with crankshaft vertical, attach the hoist to the lifting eye, and lift the engine manually, or by means of the crankshaft lifting eye and another hoist, and swing the engine to the flight position as the lifting eye is raised.
 - b. Raise the engine to the level required to align the crankcase mounting arm holes with bolt holes in the aircraft mounting.
 - c. If the engine is a -8 or -12 model, install the rubber cone bushings in front and rear seats of the mounting arm holes. place a steel washer on each mounting bolt, and push the bolts through the engine mount bosses from the rear.
 - d. Place the number of steel washers required (for correct C. G. location) between the aircraft mount and the rear engine rubber bushings.
 - e. Move the engine rearward carefully so that the mount bolts will enter the rubber bushing holes without tearing them.
 - f. Place a steel washer (supplied with engine) on each bolt end.
 - g. Install a slotted nut on each mount bolt, and tighten all nuts to 60-80 inch pounds torque. This is very important, since insufficient tightness will allow excessive vibration, whereas too much tightening will deform the rubber bushings.
 - h. Install cotter pins.
 - i. If the engine is a C90-14, -16 or 0-200 model, place a Lord mount bushing in the rear counterbore of each engine mount arm, and place a cupped steel washer on the rear side of each bushing. Push the engine carefully onto the mount bolts. Center one of the rubber hose snubbers on each of the four steel tubes supplied with the equipment, and push the tube over the end of each bolt. Install the front Lord bushings in the front mount arm counterbores and the last four cupped washers over them. Install slotted nuts on the mount bolts, and tighten each nut to 180-190 inch pounds torque. Install cotter pins.
 - j. Remove protective covering from the crankshaft taper, and remove tape which secures the shaft key, if a tapered shaft is installed.
 - k. Remove exhaust port covers and spacers, carburetor fuel inlet plug, oil pressure gauge line plug (in front of lower right mount arm), primer jet plug (left side of intake manifold), tachometer housing cover nut, and crankcase breather elbow cover, unless these were removed earlier, and install fittings for connection of aircraft parts where necessary.
1. Connect the following aircraft parts:
 - (1) Magneto switch wires.
 - (2) Throttle control cable.
 - (3) Carburetor mixture control cable.
 - (4) Carburetor air heat control.
 - (5) Oil temperature gauge.

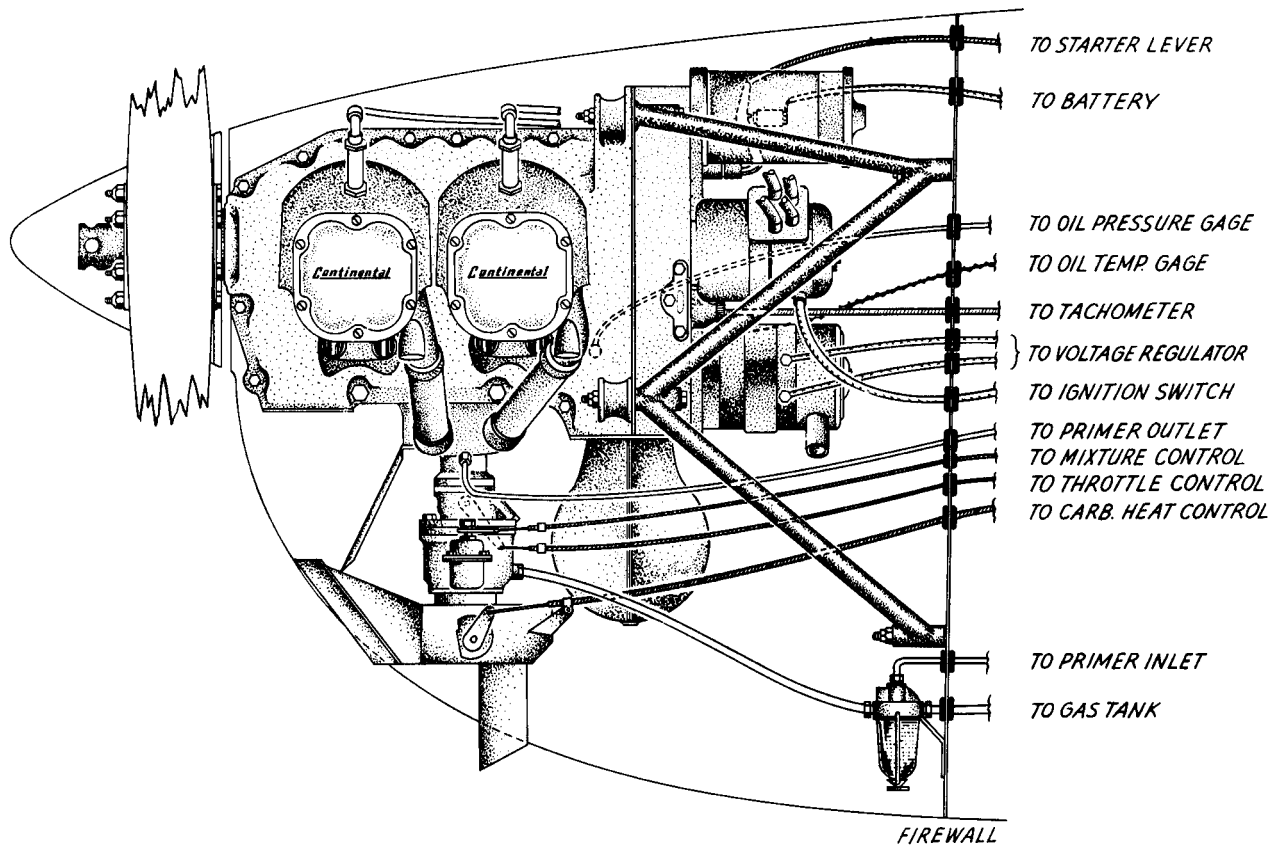

Figure 12. Typical Installation Diagram for -12, -14 & -16 Models, Side View.

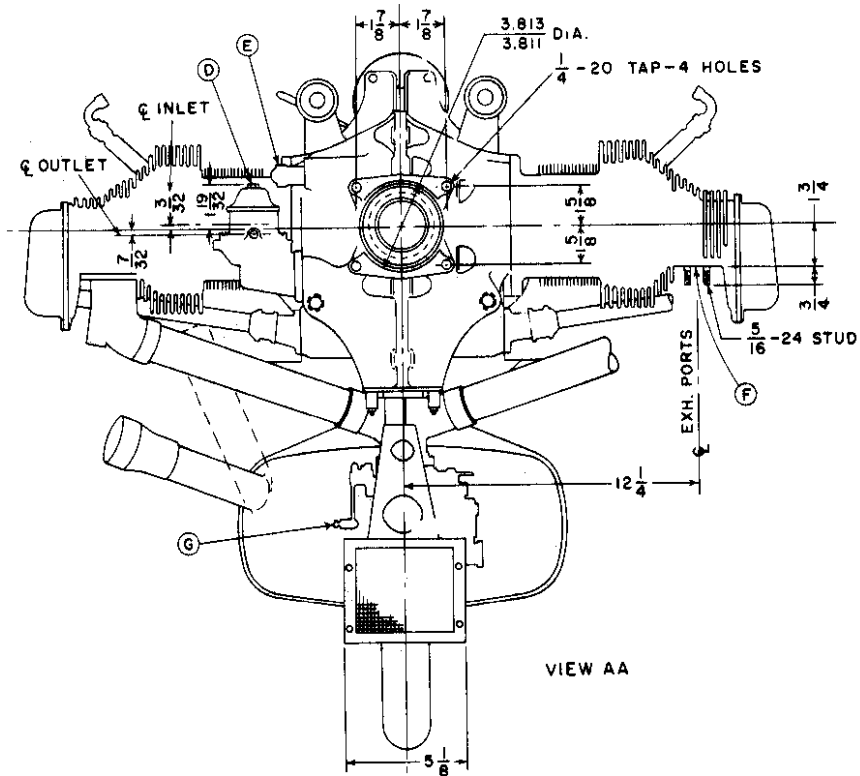
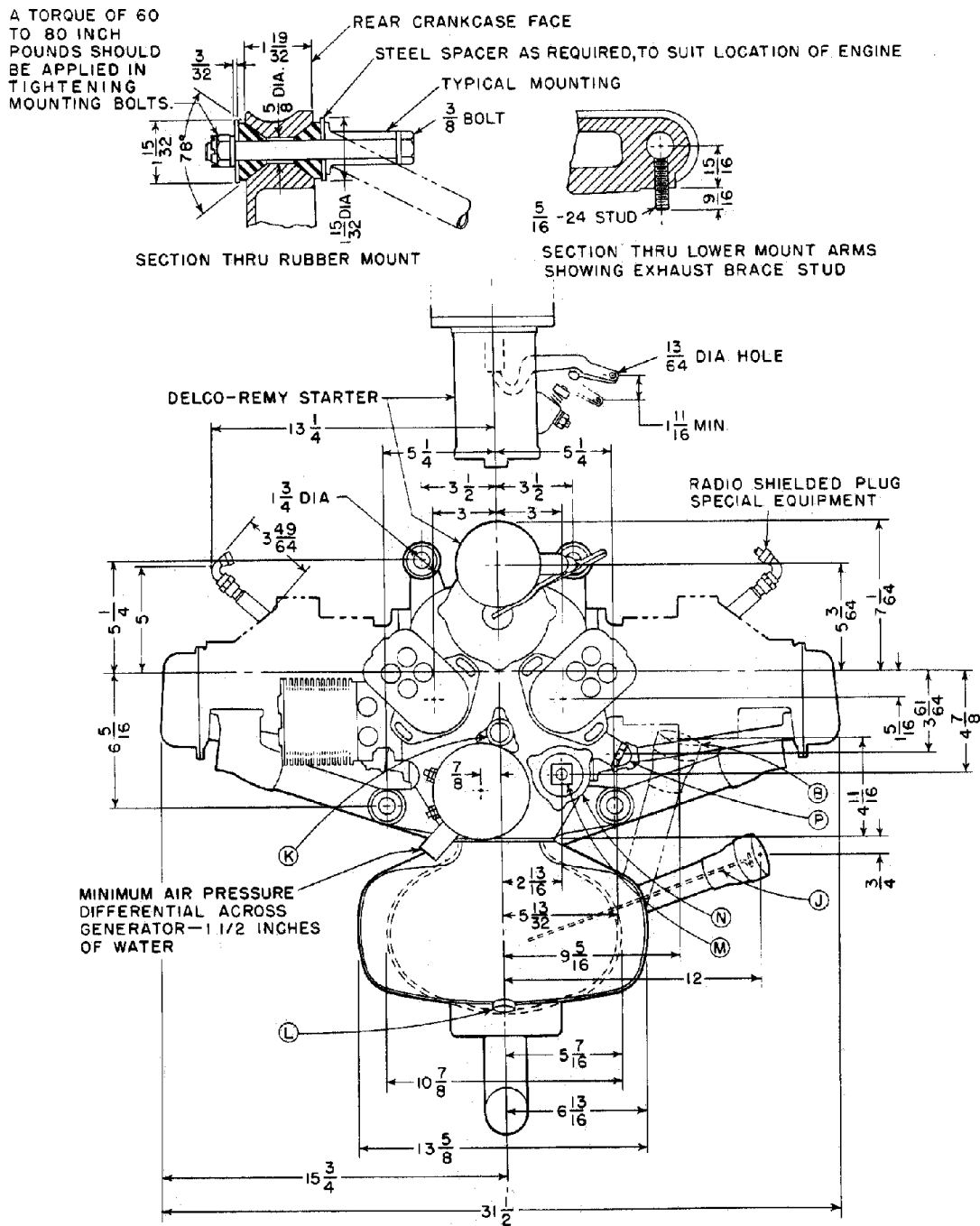

Figure 13. Installation Drawing for -12, -14 & -16 Models, Front View.



- | | |
|-------------------------------------------------|-------------------------------------------------------------------------------|
| A. Name plate | K. Tachometer drive S.A.E. standard $\frac{1}{2}$ engine Speed C.W. rotation. |
| B. Oil Filler (optional location) | L. Oil drain $\frac{5}{8}$ -18 N.F. tap and plug |
| C. S.A.E. No. 1 flanged crankshaft (optional) | M. Oil temp. capillary $\frac{5}{8}$ -18 N.F. tap |
| D. Fuel pump – special equipment | N. Oil screen |
| E. Breather connection $\frac{5}{8}$ I. D. hose | P. Oil pressure relief valve |
| F. Exhaust mounting | R. Air intake housing |
| G. Throttle control lever | S. Delco-Remy generator |
| H. Oil pressure gauge connection | T. Delco-Remy starter |
| J. Oil quantity gauge | U. Oil cooler optional special equipment |

Figure 14. Installation Drawing –12, -14 & -16 Models, Rear View.

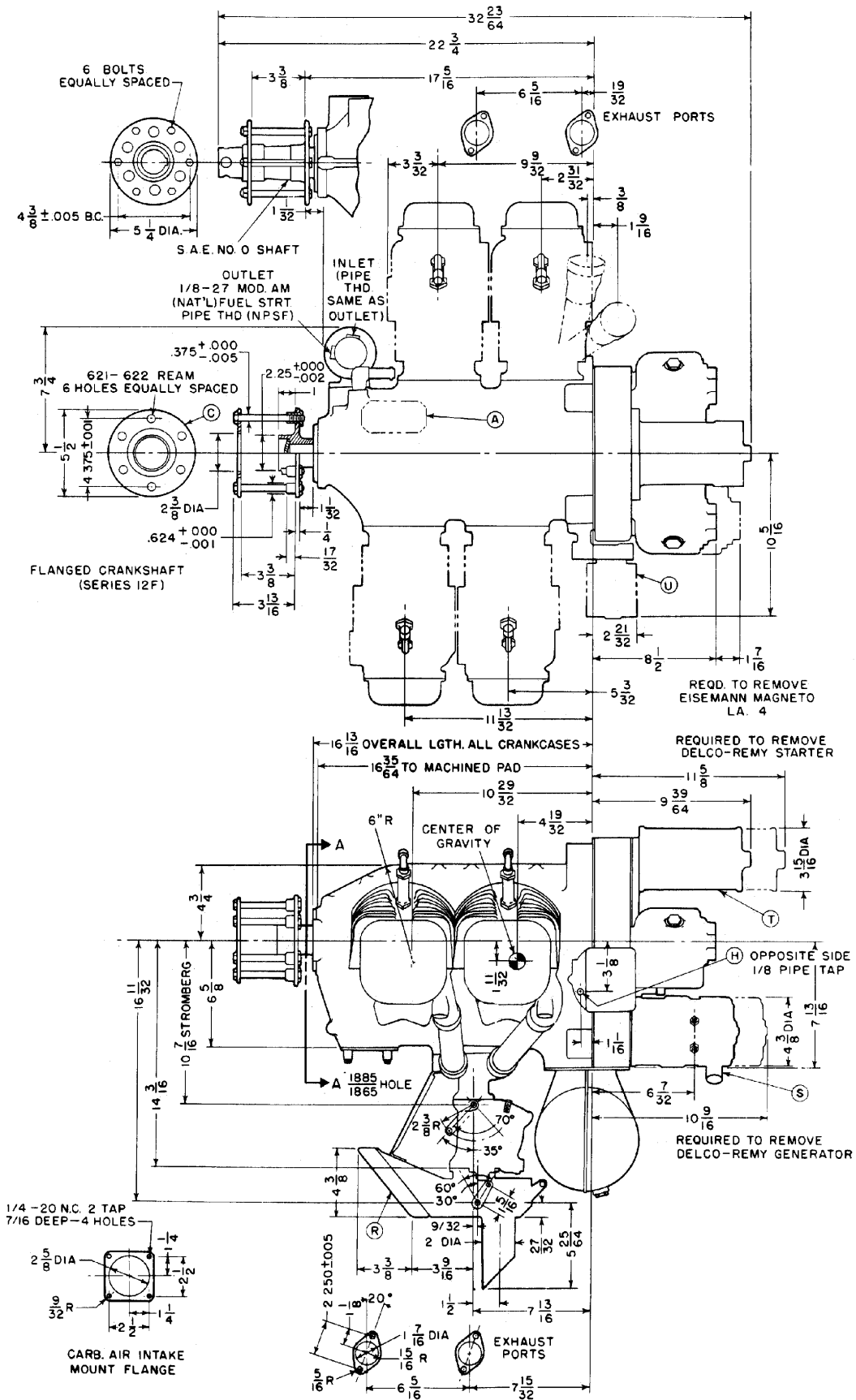

Figure 15. Installation Drawing for -12, -14 & -16 Models, Side and Top Views.

- (6) Fuel supply line to carburetor.
- (7) Tachometer drive cable and conduit.
- (8) Oil pressure gauge.
- (9) Primer discharge line and nozzle to manifold.
- (10) Electric power cable to starter (-12, -14, -16 and 0-200 models).
- (11) Wires from switch to generator "F" terminal and from regulator "GEN" terminal to generator "A" terminal.
- (12) Starter shift lever control cable (-12, -14, -16 and 0-200 models).
- (13) Crankcase breather hose or tube.
- (14) Exhaust manifold.
- (15) Air scoop tube to generator vent (-12, -14, -16 and 0-200 models).
- (16) Air heat tube to carburetor intake housing.

6-2. FUEL SYSTEMS

When a carburetor engine is installed in an aircraft with elevated fuel tank, the carburetor must be the proper parts list number and have the correct float needle seat for the gravity flow system. A different carburetor with a smaller float needle seat is required when a fuel pump is installed. In all cases, be sure that the carburetor is the correct parts list number for the make and model of aircraft, since metering differs for various installations. If a fuel pump is installed on the engine, connections to the aircraft supply line and carburetor must be made as described in paragraph 3-38 and paragraph 3-39. The normal priming nozzle is installed in a 1/8 inch N. P. T. hole in the left side of the intake manifold.

6-3. OIL SYSTEM

The lubrication system is contained with the engine, except that an oil cooler and adapter may be installed on the engine, if required. When the vacuum pump is installed on the -1-6 and 0-200 engines, an oil return line between the pump and crankcase cover must be installed. Connect the oil

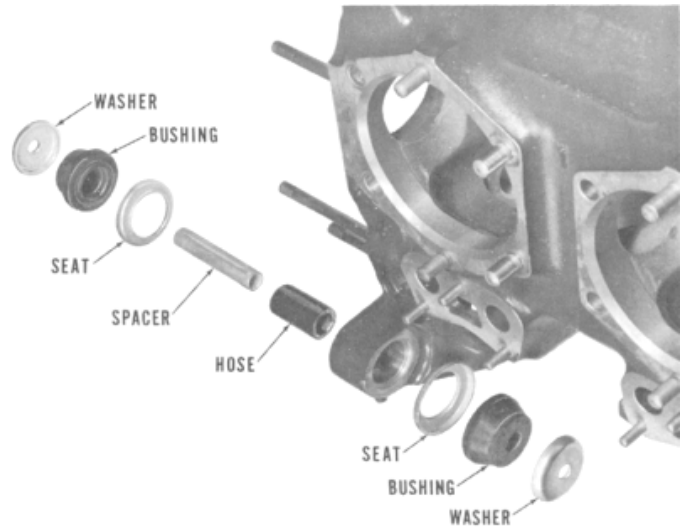

Figure 16. Engine Mounting Equipment of Models C90-14, -16 and O-200

return line to the 5/8 in. tapped hole in the left side of the crankcase cover. The oil temperature bulb is screwed into a hole in the center of the oil screen cap.

6-4. PROPELLER INSTALLATION

Make sure that the propeller is the correct type for the engine and aircraft models. If the engine is equipped with a tapered crankshaft proceed in the following manner:

- a. Install the steel hub in the propeller from the rear.
- b. place the loose flange on the front side of the propeller.
- c. Tap the hub bolts through from the rear.
- d. place a steel washer and a castle nut on each bolt end.
- e. Tighten all nuts evenly to 200-220 inch pounds torque.
- f. Check fit of hub on crankshaft taper and key.
- g. place a tapered arbor in the hub and check static balance and track of the propeller and hub assembly. Correct as necessary.
- h. Place the snap ring on the shaft nut, against the shoulder, and compress it. Tap the snap

ring into the front hub bore, pushing the nut with it, until the ring snaps into the groove.

- i. Install the propeller, hub and nut assembly on the crankshaft, and screw the nut in. Torque to 200-225 foot pounds.
- j. Install the nut locking pin with its head inside the crankshaft bore, and install a cotter pin to secure it. If the engine has a flange crankshaft the bolt holes in the rear side of the propeller must be reamed to fit over the shaft bushings. Install the propeller firmly on the shaft flange. place the moisture impervious plate on the front side of the propeller, then the loose steel flange. Insert the six hub bolts and screw them into the bushings. Tighten the bolts evenly, and install lockwire through their head holes so as to prevent loosening.

6-5. ENGINE REMOVAL

The following suggested order of disconnection and removal must be varied to suit the aircraft installation.

- a. Remove propeller.
- b. Remove engine cowling and any baffles which will interfere with removal of the engine.
- c. Drain the oil sump.
- d. Disconnect throttle control cable from carburetor.
- e. Disconnect mixture control from carburetor.
- f. Disconnect fuel supply line from carburetor or pump.
- g. Disconnect carburetor hot air tube.
- h. Disconnect carburetor air heat control cable from intake housing.
- i. Disconnect oil pressure gauge line.
- j. Unscrew and remove oil temperature capillary from oil screen.
- k. Disconnect tachometer drive conduit nut and cable.
- l. Remove primer discharge line from manifold jet.
- m. Disconnect starter shaft lever control (-12, -14, -16 and 0-200 models).
- n. Disconnect generator wires (-12, -14, -16 and 0-200 models).
- o. Disconnect ignition switch wires & om magnetos.
- p. Attach a hoist to the engine lifting eye and take up the engine weight on the hoist.
- q. Remove engine mounting bolts, starting with those at the bottom.
- r. Move the hoist or the aircraft to clear the engine, making sure that engine parts do not strike the mount.
- s. Install the engine on a support stand, assembly stand, or a shipping crate cradle, and attach it securely.
- t. Unless the engine is to be overhauled at once, cover all engine openings, after removing fittings belonging to the aircraft.

SECTION VII

OPERATING INSTRUCTIONS

7-1. PROCEDURE PRELIMINARY TO STARTING

Place engine controls in following positions:

- a. Ignition Switch: "OFF".
- b. Parking Brakes: Set.
- c. Throttle: Wide open.
- d. Mixture Control: "FULL RICH".
- e. Carburetor Heat: "COLD".

Turn the propeller through four or five revolutions.

7-2. STARTING PROCEDURE

Perform the following operations in the order named:

- a. Close throttle, if open.
- b. Turn fuel supply valve "ON" a full tank.
- c. Unless engine is still hot, prime one to four strokes with hand primer, depending on air temperature.
- d. Open throttle slightly.
- e. Turn ignition switch to "ON".
- f. Close master switch (-12, -14, -16 and 0-200 models).
- g. Start -8 models by pulling propeller through a compression stroke. Start -12, -14, -16 and 0-200 models by engaging electric starter.

CAUTION

Never engage the electric starter while the propeller is turning. Gear teeth will be chipped if this rule is violated.

In cold weather prime the engine as it starts, and continue to prime only enough to keep the engine running until it will run smoothly on the normal mixture. If the engine cannot be started after several attempts, refer to Section VIII for possible causes.

7-3. WARM-UP

As soon as the engine starts, adjust throttle to obtain approximately 800 R.P.M., and observe the following precautions:

- a. Watch oil pressure gauge closely. If no pressure is indicated within 30 seconds, stop the engine, and determine the cause.
- b. Do not allow engine speed to exceed 800 R.P.M. during the first minute. Cold oil will not circulate rapidly enough for adequate lubrication at higher speeds.
- c. Leave carburetor mixture control in "RICH" position for all ground running.
- d. Open throttle gradually until the engine is running at approximately 1200 R.P.M. Do not exceed this speed until oil temperature has reached 750 F.
- e. Avoid prolonged running on the ground. Engine cylinders do not receive enough cooling air flow unless the aircraft is moving forward at high speed.

7-4. GROUND TEST

When ready to take-off, set parking brakes and check the following:

- a. Mixture control: "FULL RICH"
- b. Oil pressure at full throttle: 30-60 p.s.i.
- c. Oil temperature (minimum): 750 f.

- d. Decrease in speed when ignition switch is turned from "BOTH" to "L" or from "BOTH" to "R". Maximum 75 R.P.M.
- e. Carburetor air heat: Move control to full "HOT" position, and observe decrease in engine speed if air heater and control are operating properly. Return control to full "COLD" position.

NOTE

Under some conditions, ice may form in the carburetor during ground test. It must be eliminated before take-off.

- f. Fuel supply valve: "ON", full tank.
- g. Propeller pitch control (if installed): High R.P.M.

7-5. TAKE-OFF

Usually the throttle will be opened wide for take-off, however, it is possible to exceed the rated take-off speed of the engine if an automatic or controllable pitch propeller is improperly adjusted or if a fixed pitch propeller of sub-standard dimensions is installed. Rated take-off speed must not be exceeded at any time. With approved propeller in proper adjustment, the take-off speed will not be realized until the aircraft is nearly airborne. If a special take-off speed is specified for the engine model, it must not be maintained longer than one minute, in order to prevent overheating. It is advisable to reduce speed to the normal rating for the engine model as quickly after take-off as immediate obstacles are cleared.

7-6. CLIMBING

Except in unusual situations, it is advisable to reduce engine speed below maximum and to restrict the angle of climb so as to maintain adequate air speed to assure proper cylinder cooling. This is particularly important in warm weather.

7-7. LEVEL FLIGHT

When the desired cruising altitude has been reached, adjust the throttle (and propeller pitch control, if installed) to obtain the specified cruising R.P.M. With hydraulic controllable propellers,

reduce manifold pressure first with the pitch control: then reduce R. P. M. with the throttle. During flight, observe the following procedures and precautions:

- a. If a Stromberg carburetor is installed leave mixture control in the "FULL RICH" position at altitudes less than 5000 ft. above sea level. If a Marvel-Schebler carburetor is installed the mixture control may be adjusted to obtain best rich power at any cruising altitude.
- b. To obtain best rich power, move the mixture control toward the "LEAN" position, and watch the tachometer closely to detect any change in engine speed. If speed decreases or remains unchanged return the control to the "FULL RICH" position. However, as the control is moved to lean mixture an increase in speed will ordinarily result if an automatic enrichment has occurred, due to decreased air pressure. Further control movement will cause a decrease in speed. when the position of maximum speed has been found, return the control toward "RICH" position until engine R.P. .M. decreases just perceptibly. This setting produces the best power obtainable under existing atmospheric conditions with a slightly rich mixture to prevent overheating.
- c. If the mixture control is in any but "FULL RICH" position change the setting, as described in paragraph 7-7b., for each change in altitude or power setting. If a Stromberg carburetor is installed return the mixture control to the "FULL RICH" position before letting down below an altitude of 5000 feet.
- d. The carburetor air heat control should be in the "COLD" position unless icing conditions are encountered. Formation of ice in the carburetor is indicated by a loss in R.P. .M. (usually progressive). To overcome ice formation, flfst apply full heat to melt the ice which has formed; then close the hot air valve in small steps until only enough heat is applied to prevent further ice formation.
- e. Observe engine oil temperature and pressure frequently. Unless other temperature and pressure gauges are installed, these indications

will give the first warning of trouble. If a rapid or continuous rise in oil temperature or drop in oil pressure is noticed the aircraft should be landed without delay and the cause determined.

7-8. LET-DOWN AND LANDING

Before the throttle is retarded, place the mixture control in the "FULL RICH" position. During let-down and final approach:

- a. Retard throttle to obtain approximately 1200 R.P.M.
- b. The mixture control must be in "FULL RICH" position prior to landing. If a long glide is made, it is good practice to "gun" the engine periodically to clear the cylinders and retain engine temperatures so that the engine will remain ready for instant use.
- c. Carburetor heat is available only when engine output is well above that for idle; therefore, the carburetor heat control should be applied before closing the throttle and "off" after closing the throttle so that full power will be available if required in an emergency.

CAUTION

Do not open a carburetor throttle abruptly after idling in flight. To do so may cause the engine to stop. If the engine tends to stop while gliding with closed throttle, the idling mixture should be readjusted. If the engine stops when throttle is opened suddenly, return the throttle to the closed position and open slowly or operate the primer for one or two strokes.

7-9. STOPPING THE ENGINE

- a. Normally the engine will have cooled sufficiently during the glide and taxiing period to permit placing the ignition switch in the off position without additional idling. If taxi time has been excessive, operate the engine at 800-1000 RPM for two or three minutes before stopping.

- b. If the engine is equipped with a Stromberg N A-S3A1 carburetor, stop the engine from idling speed by turning the ignition switch to "OFF". As the engine stops open the throttle rapidly and leave it open to prevent after firing. If the carburetor is a Marvel-Schebler MA-25SP A, stop the engine by moving the mixture control to the "full lean" position, where it acts as an idle cut-off. Do not open the throttle, because it actuates the accelerator pump and rapid opening will flood the engine.

7-10. LUBRICATING OIL

Teledyne Continental Aircraft Engines are certificated on straight mineral oil. Detergent oils are not a requirement. It is recognized that for engine operation in extreme ambient temperature ranges of high or low temperatures, detergent oils show advantages of coping with sludge, varnish and carbon formation in the engine, and improved performance can be obtained for aircraft operating under these adverse conditions. For obvious reasons, we do not propose to indulge in testing of any oils to ascertain whether or not they meet our specifications MHS-24B. The proof of compliance rests with the oil manufacturer. Recommendations relative to transition from a straight mineral oil to a detergent oil, as outlined in Federal Aviation Administration "Power plant Branch Report No. 1" titled "Evaluation of Aircraft Engine Fuels and Lubricating Oils", apply to the use of Specification MHS-24B detergent oil. It is safest and simplest to begin use of this oil when the engine is new or just major overhauled. However, if an engine has been using straight mineral oil for a considerable period of time, and it is desired to change MHS-24B oil, it is generally agreed that the oil should be drained after five or ten hours of operation and the condition of the oil screen checked. If an abnormal amount of sludge is found, the oil should be changed and the screen should be checked at approximately five hour intervals, until the condition of the screen appears normal. Teledyne Continental Motors approves the use of only those detergent oils meeting oil specifications MHS-24B.

7-11. VISCOSITY

Viscosity grades of oil, as listed in Table XVIII, should be used in season, according to the prevailing air temperature. In extremely cold

weather it is advisable to drain the oil sump immediately after stopping for a long period and to warm the oil to 100° F. before refilling the sump. To prevent excessive cooling of the oil sump and excessively high oil viscosity in cold weather, the sump may be covered with an oil-proof lagging.

7-12. OIL CHANGE PERIODS

Under normal operating conditions, engine sumps should be drained and refueled with fresh oil after each 30 hours of operation. Condition of oil and oil screen after this period will determine whether the operating time between oil changes should be altered to suit local conditions. Under adverse conditions of dust and humidity, the operating period may need to be reduced to 20 hours.

7-13. OIL CHANGE PROCEDURE

Always drain engine oil immediately after warming up the engine to obtain an oil temperature of 100° F. place a clean container under the sump. Remove the drain plug, and allow the old oil to drain

completely. When it is reinstalled, use a new copper-asbestos gasket and safety with lockwire. Remove and inspect the oil screen. If the screen contains heavy sludge deposits or if the drained oil is highly diluted, more frequent oil changes will be advisable. If many or large metallic particles are found on the screen or in the drained oil (except machinings in new engines) the engine is in need of overhaul. clean the screen in unleaded gasoline. Replace it with a serviceable gasket; tighten the cap securely, and install lockwire. Replace the oil temperature capillary. Refill the sump with fresh oil to the gauge "FULL" mark.

7-14. ENGINE FUEL

These engines are designed to operate efficiently on gasoline of aviation quality with octane ratings at least equal to those specified in Table XIII. Tetraethyllead content should not exceed 1/2 cc. per gallon. The fuel should be free from water and as free as possible from solid particles.

TABLE XVIII RECOMMENDED OIL VISCOSITY GRADES

| | | |
|-------------------------|---------------|---------------|
| AMBIENT AIR TEMPERATURE | Below 40°F | Above 40°F |
| OIL VISCOSITY GRADE | S.A.E. No. 20 | S.A.E. No. 40 |

When average ambient air temperature is approximately at the dividing line of the above temperature ranges, use the lighter oil.

SECTION VIII

ENGINE TROUBLES AND SERVICE REPAIR

| TROUBLE | PROBABLE CAUSE | REMEDY |
|------------------------|-----------------------------------------------------|-----------------------------------------------------------------------------------------------------------|
| Engine does not start. | Insufficient fuel. | Fill tank. |
| | Fuel does not reach carburetor. | Clean tank vents, blowout supply line, replace shut-off valve, repair pump, clean filter. |
| | Carburetor float valve stuck shut. | Remove carburetor and repair. |
| | Carburetor screen or jets plugged. | Remove and clean. |
| | Insufficient priming (weak explosions). | Repeat starting procedure with more priming. |
| | Excess priming (puffs of black smoke). | Clear cylinders by turning propeller several revolutions, with ignition switch "OFF", throttle wide open. |
| | Engine hot (Vapor lock in fuel system). | Disconnect fuel line at carburetor and purge system. |
| | Low battery charge | Recharge battery. |
| | Cold oil | Turn propeller by hand several revolutions to break loose congealed oil. Also refer to paragraph 7-11. |
| | Incorrect starter adjustment. | Readjust shift lever screw. Refer to paragraph 10-27. |
| | Spark plugs fouled | Remove and clean. Check gaps. |
| | Spark plug cables defective. | Replace defective parts. |
| | Magneto breaker points burned or fouled. | Remove oil from breaker. Replace defective condenser. |
| | Magnetos incorrectly timed internally or to engine. | Check and correct timing to Overhaul if internal engine. |

| TROUBLE | PROBABLE CAUSE | REMEDY |
|-------------------|------------------------------------|-----------------------------------------------------------------------------|
| Irregular idling. | Incorrect idle mixture adjustment. | Correct carburetor adjustment. |
| | Carburetor idle air bleed plugged. | Disassemble, as required, and clean. |
| | Spark plugs fouled. | Remove and clean. |
| | Leak in air induction system. | Tighten loose joints. Replace damaged parts. |
| Rough running. | Propeller out of balance. | Remove and inspect. |
| | Engine mount bolts loose. | Tighten (Refer to Section XVIII). |
| | Fouled spark plugs. | Remove and clean. Inspect gaps. Replace worn valve guides or piston rings. |
| | Defective spark plug cables. | Test for break-down at high voltage. |
| | Cracked magneto distributor block. | Overhaul magneto. Check for very fine cracks in block. |
| | Worn cam lobe. | Overhaul engine. |
| | Defective valve lifter. | Remove and test hydraulic unit. Replace if worn. |
| | Scored valve stems. | Replace valves and guides. |
| | Warped valves. | Replace. Grind seats. |
| | Detonation. | Use specified fuel. Keep cylinder head temperature below specified maximum. |

| TROUBLE | PROBABLE CAUSE | REMEDY |
|--------------------|----------------------------------------------|-----------------------------------------------------------------------------------------------------------------|
| Poor acceleration. | Engine not warm enough. | Continue warm-up. |
| | Defective throttle control. | Check for binding, kinks, slipping, worn parts. |
| | Plugged air filter. | Remove and clean filter. |
| | Idling mixture too lean. | Readjust. |
| | Idling jet plugged. | Clean carburetor. |
| | Water in fuel. | Drain sediment trap. |
| | Leak in air induction system. | Check all joints and throttle shaft bearings. |
| Low power. | Defective ignition cable. | Test for high voltage leaks. Replace parts. |
| | Scored valve stems. | Replace valves and guides. |
| | Warped valves. | Replace valves. Grind seats. |
| | Defective magneto. | Overhaul magneto. |
| | Throttle not fully open. | Readjust linkage. |
| | Carburetor air heat valve not closing fully. | Remove filter, inspect valve. Straighten plate. |
| | Incorrect propeller installed. | Check specification and propeller model. Replace. |
| | Propeller blades warped. | Inspect pitch. Replace. |
| | Ice forming on carburetor throttle valve. | Apply full carburetor air heat. |
| | Air filter plugged. | Remove and clean. |
| | Fuel flow restricted. | Inspect tank vents. Inspect shut-off valve. Clean strainer. Clean carburetor screen. Blow out fuel supply line. |
| | Worn cylinders, pistons and/or piston rings. | Overhaul engine. |

| TROUBLE | PROBABLE CAUSE | REMEDY |
|-----------------------|----------------------------------------------------------------------------|------------------------------------------------------|
| Low oil pressure. | Low oil supply | Replenish. |
| | Low oil viscosity. | Drain sump. Refill with correct grade. |
| | Plugged oil screen. | Remove and clean. |
| | Dirt on oil pressure relief valve seat. | Clean plunger and seat. Replace dirty oil. |
| | Oil pressure relief valve seat worn. | Overhaul engine. Refinish valve seat. |
| | Oil pressure relief valve plunger sticking. | Remove cap and plunger. Clean parts. |
| | Oil pump suction tube screen plugged. | Remove sump. Clean screen. |
| | Engine bearings worn. | Overhaul engine. |
| | Oil pressure gauge defective. | Test gauge, and replace or repair. |
| | Internal oil leak. | Overhaul engine. |
| High oil temperature. | Cracked crankcase cover casting, defective oil pump, leaking suction tube. | Overhaul engine. Replace damaged parts. |
| | Low oil supply. | Replenish. |
| | Dirty or diluted oil. | Drain sump, and fill with fresh oil of proper grade. |
| | Winter baffles installed. | Remove in warm weather. |
| | Prolonged ground operation at high speed. | Avoid prolonged running on the ground. |
| | Excessive rate of climb. | Avoid low air speed. |
| | Lean fuel-air mixture. | Refer to Section X. |

SECTION IX

PERIODIC INSPECTION AND MAINTENANCE

9-1. DAILY INSPECTION.

Engines should be inspected prior to first flight and after the last flight each day. The purpose of this inspection is to detect serious maladjustment, leaks, looseness and other developments of a dangerous character. Inspect the following points and make necessary corrections:

- a. Inspect propeller for nicks, cracks and other damage. Ascertain that all attaching parts are tight and secure.
- b. Check operation of throttle control for free operation and full travel.
- c. Check fuel meter bowl for water and sediment. Clean, if necessary, and safety.
- d. Inspect oil gauge to estimate rate of consumption and determine need of replenishment.
- e. Refill fuel tanks, and inspect vent openings in caps.
- f. Trace any oil leaks or fuel leaks to their source and correct.
- g. Wipe any oil from surfaces of engine and cowling.
- h. Inspect spark plug cable terminals and brackets for tight installation and for any damage.
- i. Inspect accessory attachments, control attachments and cylinder baffle attachments and fits. Baffles must fit snugly on cylinders.
- j. Inspect starter and generator electrical connections and magneto switch wire terminal connections.
- k. Visually inspect entire engine for loose or missing nuts, palnuts, screws and lockwire. Properly safety plugs.

1. Inspect air intake filter for excessive dirtiness.

NOTE

The air filter should be cleaned as it becomes dirty, every day under severe conditions. Whenever the intake filter is found to be restricted by dust it must be removed and cleaned. To remove the filter, turn each of the four locking studs to the left, and draw the filter forward. Remove the gasket if it adheres to the filter. Clean the filter element with mineral spirits solvent used for cleaning parts. Use fresh solvent for final cleaning and dry thoroughly. If avoidable, use a jet of dry compressed air to blow off all liquid on the surfaces. If, after cleaning, the surface of the air filter shows metallic wires through the remaining flocking material, the filter is no longer effective and should be replaced with a new part. Dip the filter in clean engine lubricating oil, and allow to drain overnight before installing. Replace the filter with a gasket in serviceable condition, making sure to push each stud home before turning to lock. A damaged filter will allow dust and foreign matter to enter the combustion chambers, which results in a high rate of cylinder, piston and ring wear.

9-2. FIRST FIFTY HOUR INSPECTION

Inspect each engine after the first fifty hours of operation when new, remanufactured or overhauled, giving particular attention to the following checks and adjustments.

- a. Inspect propeller for tightness and security of attaching parts and check track of blades. !
- b. Remove palnuts, and check tightness of cylinder retaining nuts with a torque wrench. Refer to Section XVIII for correct torque.
- c. Check fit of all cylinder baffles on cylinder fins.

- d. Remove lockwire, if installed, and check tightness of oil sump retaining nuts. Tighten to take up gasket set, and safety.
 - e. Remove palnuts from stud, if installed, and check tightness of retaining nuts on accessories and crankcase cover. Check tightness of upper starter retaining bolts. Tighten all nuts and bolts, as necessary, to take up gasket set. Do not tighten excessively.
 - f. Remove palnuts, if installed, from pushrod housing adapter studs, and check tightness of adapter retaining nuts. Tighten, as necessary.
 - g. Check tightness of hose clamps on intake pipes, and pushrod housing rubber connectors. Do not tighten excessively.
 - h. Check tightness of retaining nuts of carburetor, and air intake. Tighten, if necessary to take up gasket set, and replace lockwire or other safety devices which were removed.
 - i. Check tightness of rocker cover retaining screws, and tighten, if necessary, to take up gasket set. Tighten screws evenly around each cover. Do not tighten excessively.
- a. Start and warm up the engine to obtain an oil temperature of 1000 F. During this period, check all engine instruments to detect fluctuations or other abnormal indications. Test operation of all engine controls, and observe engine response. Restrict running to the minimum time necessary for warm-up and instrument checks. In warm weather prolonged running for tests should be performed in flight.
 - b. Immediately after stopping the engine, drain the oil sump, and carry out the complete oil change and inspection procedure described in paragraph 7-14. Refer to Table XVIII for correct oil viscosity grade.
 - c. Check the propeller for visible defects, track within 1/8 inch, tightness of attaching parts. Remove the engine cowling.
 - d. With ignition switch "OFF" and throttle fully open, turn the propeller, and test compression in all cylinders. Uniformly low compression will usually indicate the need of overhaul. Low compression in one or two cylinders only may be caused by defective valve lifters.
 - e. Remove rocker covers, and inspect all parts within each rocker box for breakage, wear and full lubrication. Remove all spark plugs, and observe valve lift while the propeller is turned slowly. Replace rocker covers with new gaskets, and tighten retaining screws evenly.
 - f. Remove magneto breaker covers. Wipe any oil from breaker housings. Inspect magneto points for pitting or burning (indicating a defective condenser). If magneto points are suspected of incorrect gap or opening position, or if the breaker assembly must be replaced, refer to Section X for procedures. When finished, replace the breaker covers.
 - g. Clean spark plugs. Check and adjust electrode gaps. (Refer to current Spark Plug Application Bulletin.) Test plugs in dry compressed air at 100 psi pressure. Reinstall plugs with serviceable gaskets, and tighten to specified torque.

NOTE

The first fifty hours of operation is a "shakedown" period, during which soft gaskets take a permanent compression or "set", and certain other parts may become slightly less tight than when initially installed. A general inspection and necessary retightening after this period will help to prevent oil leaks and other annoying troubles which result from the nature of materials subjected to high temperatures and stresses.

9-3. 100-HOUR PERIODIC INSPECTION

This inspection should be made to coincide with a regular oil change. The following inspections and servicing should be considered preventive maintenance, and whatever maladjustments, looseness, wear or damage are discovered will indicate and demand appropriate readjustment, repair or replacement of parts, accessories and/or instruments.

- h. Examine cylinder head fins for breakage or serious cracks, and make sure that cylinder baffles fit closely and firmly on the fins.
- i. Inspect all spark plug cables for condition of terminals, cracked or chafed insulation, attachment and fit of brackets and installation of rubber grommets (in unshielded systems). Reconnect cables to spark plugs.
- j. Inspect all electrical connections and magneto switch wires for firm attachment, proper support and insulation condition.
- k. Inspect all connections and attachments in the induction system, including air intake housing and air filter, carburetor and cylinder elbows.
- l. Remove and service the air filter as described in the note following paragraph 9-1-1.
- m. Test operation of all engine controls, and inspect control connections for wear and looseness and conduits for firm support.
- n. Remove fuel filter bowl. Empty and clean bowl and screen, and reassemble parts. Remove carburetor screen; clean, and replace. Turn on fuel supply, and check for leaks.
- o. Remove cotter pins from engine mount bolts, and test torque on nuts. Tighten all nuts 60-80 inch pounds torque, and replace cotter pins. (Lord mount bushing bolts of model C90-14, -16 and 0-200 require 180-190 inch pounds torque.)
- p. Test adjustment of starter lever. (Refer to paragraph 10-27.)
- q. Remove all dirt and oil from the exterior of the engine and accessories and dry thoroughly.
- r. Start the engine and warm up as described in paragraphs 7-2 and 7-3. Perform the ground test described in paragraph 7-4. Stop the engine and inspect for fuel and oil leakage. Replace cowling.

SECTION X

ADJUSTMENT AND MINOR REPAIR

10-1. CARBURETORS

10-2. REMOVAL

Disconnect and remove parts in the following order:

- a. Shut off fuel supply; then disconnect supply line from the carburetor fuel inlet.
- b. Loosen clamp screw in carburetor throttle lever swivel on right side, and pull control cable from swivel.
- c. Disconnect control cable or rod from mixture control lever. This lever is located on top of the float chamber at the left side on the Stromberg carburetors, and at the rear of the Marvel-Schebler carburetors.
- d. Remove carburetor heat valve control cable clamp from its support at left rear corner of intake housing, and remove control cable end from valve lever.
- e. Remove air filter from intake housing.
- f. Remove lockwire from heads of two bracket screws inside the intake housing and from slotted retaining nuts at carburetor top and bottom flanges. Current production engines no longer use drilled studs for attaching the air intake housing and carburetor and use plain hex nuts and lock washers in these locations.
- g. Remove the two bracket screws and the four nuts or nuts and lockwashers attaching the intake housing to carburetor. Remove the intake housing.
- h. Remove the four carburetor attaching nuts or nuts and lockwashers and remove the carburetor and gasket from the manifold.

CAUTION

Do not use sharp or pointed tools to remove gasket material. Damage to parting surfaces will result in premature replacement of an otherwise serviceable part.

10-3. INSTALLATION

Coat the carburetor upper flange gasket with a film of non-hardening gasket paste, and place the gasket on the manifold studs. Install the carburetor on the manifold with the throttle lever on the right side. Install four slotted hex nuts and plain washers if the manifold studs are drilled or plain washers, lockwashers and plain hex nuts if manifold studs are undrilled. Secure slotted hex nuts with lockwire. Similarly, install the intake housing on the carburetor bottom flange. Attach the support bracket to the intake housing with the two fillister head screws and plain washers. Install lockwire to connect and secure the screw heads. Replace the air filter, and push each locking stud fully home before turning it to lock. Apply a thin film of gasoline and oil resistant lubricant to the first three pipe threads and install a 1/4 inch pipe and tube connector of the tube required by the aircraft, in the carburetor fuel inlet. Reconnect throttle, mixture and air heat valve controls, and test for full range operation. If the throttle lever motion is short, loosen the lever clamp screw, and readjust the lever position on the throttle shaft until the control cable will move it through the full range between stops.

10-4. STROMBERG CARBURETOR ADJUSTMENT

The main metering jet is a fixed orifice type. Its size is determined by factory test, and no adjustment is provided. The rear adjusting screw on the throttle shaft stop assembly controls the open throttle position. It is set at the factory to contact the body stop when the throttle valve is parallel to the barrel, and no further adjustment is required. This screw

stops forward motion of the throttle lever. The front screw on the throttle stop assembly adjusts the idling position of the throttle valve by stopping rearward motion of the lever. The slotted and knurled brass screw head projecting from the oblique boss behind the throttle body is part of the idle mixture adjusting needle valve. To adjust idle speed and mixture, proceed as follows:

- a. Start the engine and warm up in the normal manner.
- b. Slightly loosen the idle adjusting stop clamp screw.
- c. Close the throttle, and observe engine speed. Do not lock the throttle.
- d. Turn the idle speed adjusting screw in (right hand) to increase idling speed or out (left hand) to reduce. Set idling speed at approximately 600 R.P.M. with throttle closed against the stop.
- e. Turn the idle mixture adjusting needle valve to the right to lean mixture or left to enrich. Adjust until engine runs smoothest; then turn to the left very slightly. Again observe engine speed and correct with the speed adjusting screw. Again adjust idling mixture for smoothest operation and enrich by turning valve to the left slightly. When smooth idling at 600 R.P.M. is obtained the mixture will be slightly on the rich side for safety.
- f. Tighten the idle speed stop clamp screw, and secure the idle mixture needle valve with lockwire.

NOTE

The Stromberg Parts List number of each carburetor is stamped on the lower flange under the throttle lever. The Continental part number is stamped on an adjacent side of the flange. Make sure that the proper carburetor for the engine model and aircraft is installed. Otherwise, no adjustment can be made, except by disassembling the carburetor and changing jets, to provide correct fuel metering at high speed.

10-5. MARVEL-SCHEBLER CARBURETOR ADJUSTMENT

If after checking all other possibilities, it is found necessary to readjust this type of carburetor, proceed as follows:

- a. Start and warm up the engine in the normal manner.
- b. Set throttle stop screw to obtain an idle speed of 500 R.P.M.
- c. Turn idle adjusting needle out slowly until engine "rolls" from richness, then turn in slowly until engine lags, or runs irregularly from leanness. This step will determine the adjustment range and how the engine operates under extreme idle mixtures.
- d. From the lean setting, turn needle out slowly to the richest mixture that will not cause the engine to "roll" or run unevenly. This adjustment will in most cases give a slower idle speed than a slightly leaner adjustment with the same throttle stop screw setting, but will give smoothest idle operation. A change in idle mixture will change the idle speed and it may be necessary to readjust the idle speed with the throttle stop screw to the desired point. The idle adjusting needle should be from 3/4 to 1 turn from its seat to give satisfactory idle mixture.

CAUTION

Care should be taken not to damage the idle needle seat by turning the idle adjusting needle too tightly against seat, as damage to the seat will make a satisfactory idle adjustment very difficult.

10-6. MAINTENANCE

Once the carburetor is installed and the controls and idling properly adjusted, very little attention is required. At each Periodic Inspection all adjustments and attachments should be inspected for security. The large hex plug in the left side of the float chamber at the rear covers the fuel screen. A drain plug is screwed into the bottom of the float chamber. These should be removed to clean the screen and to flush accumulations of dirt and water from the chamber as frequently as necessary.

10-7. MAGNETOS

10-8. REMOVAL

Spark plug cables may be removed from Eisemann AM-4 magnetos merely by pulling the terminals from the distributor blocks. To remove the cables from Eisemann LA-4 magnetos, first remove the breaker cover; then back out the distributor block screws to free the cable terminal eyes. Unscrew the union nuts from the cable plate spigots, and pull the cables carefully from the distributor housing. To remove the spark plug cables from Bendix S4RN-21, S4LN-21 or Slick magnetos, the high tension outlet plate must be freed by removing the retaining screws. Carefully pull the plate, grommet and cable assembly from the magneto housing. Remove AM-4 magneto switch wires by loosening the hex nuts which attach them to the rear side studs. To remove Eisemann LA-4 or Bendix switch wires, unscrew the union nut which attaches each wire terminal to the magneto housing. LA-4 switch wire terminal spigots are on the left side near the bottom of the breaker housing. Bendix spigots may be either at the bottom or at the rear of the housing. To free the magneto (any type), remove the two palnuts, then the two plain hex nuts from studs through the magneto mount flange slotted holes. Current production engines no longer use palnuts at the magneto mount flange, but use plain washers and lockwashers, together with the plain hex nut. Except for gasket adhesion, the magneto will be free and may be pulled straight to the rear. The drive gear will come with the magneto.

10-9. INSTALLATION AND TIMING

Unless the original magneto drive gear is unserviceable, install it on the replacement magneto in the same manner as it was positioned on the original magneto. This requires only loosening the gear retaining nut, removal and installation of the gear and tightening and pinning the nut.

10-10.

Before installing a replacement magneto, it is advisable to test the opening position of the breaker points. This should occur at the same time that timing marks are aligned when the drive gear is turned in the direction of its normal rotation. Magneto timing marks are located and may be inspected as follows:

- a. Eisemann AM-4: There are no timing marks for installation. Locate No.1 firing position roughly by inserting a cable in the marked outlet socket holding the bare cable end near the bare mount flange, and spinning the shaft through the firing positions. When spark occurs, the rotor has just passed No.1 position.
- b. Eisemann LA-4: There are no exact timing marks for installation purposes. When breaker points are installed at assembly their opening position is adjusted to occur when the rotor magnet has passed its neutral position and is separated from the pole shoe .059-.138 inch (edge gap). With this adjustment made, the breaker cam opens the points a maximum "gap" of .018-.022 inch. The distributor terminal for No.1 spark plug cable is located radially in line with the timing window in the distributor block. When the rotor arm is centered in the timing window, the magneto is in position to fire No.1 spark plug, and the breaker points should be opening. Remove the distributor cover at the rear to observe the timing window and to connect spark plug cables. Depress the impulse coupling pawls so that they will pass under the stop pins to permit forward rotation of the magneto shaft.
- c. Bendix S4RN-21 and S4LN-21: The fixed timing mark is located inside the breaker housing at the top and is covered by an aluminum hex head screw plug. The timing mark or pointer in the housing will be seen in the center of the opening when the plug is removed. A white tooth on the distributor gear aligns with the fixed mark at the No.1 firing position. The breaker points will open at the same time if internal timing is correct. Also inspect the position of the impulse coupling pawl stop pin. It should be installed in the No.2 hole at the lower right side of the magneto pilot shoulder, as viewed from the drive end, in model S4RN-21, and in the No. 3 hole at the lower left side in model S4LN-21. The first named model is used on -8 model engines and requires an impulse coupling with pawls so located that they will stop against the pin when the shaft is turned clockwise, as viewed from the drive end, whereas the S4LN-21 coupling pawls must be

stopped by the pin when the coupling is turned counterclockwise, as in operation of -12, -14, -16 and O-200 models.

- d. The Slick Model 4000 has fixed timing marks which appear as red marks through the vent window on the side of the magneto which carries the Slick Trademark and as black marks through the vent hole on the opposite side.

NOTE

The special breaker grounding spring used on these magnetos short-circuits the primary when the switch wire terminal is not installed. A strip of thin cord may be inserted between the spring and the breaker housing for insulation before the timing light is connected. This requires removal of the breaker cover plate. Alternatively, the plate may be left in place and the timing light lead connected to a short lead wire assembled into a Bendix switch wire terminal assembly, which can be installed in the terminal spigot of the breaker housing or cover plate to depress the grounding spring, breaking its contact with the housing and making contact with the insulated breaker point. Connect the other timing light lead to a bare spot on the magneto housing.

10-11

Refer to Table X for correct crankshaft angles to be used for timing magnetos to each engine model. Crankshaft angles of 240, 260, 300, and 320 B.T.C. and a top dead center mark between the letters "TC" are stamped on the edge of flange type crankshaft propeller flanges. These marks indicate positions of No.1 crankpin when they are aligned with the crankcase split line below the crankshaft. Figure 33 illustrates one method of aligning a crankshaft flange timing mark with the split, with the propeller removed. Another method, which does not require removal of the propeller, involves the use of a triangular piece of sheet metal, on which an index mark is scribed perpendicular to the base and passing through the apex. When the base of this indicator is placed on the machined front surface of the crankcase, with the index mark at the split line, the apex will indicate No.1 crankpin angles. Figure 32 illustrates the use of a special tool to locate No.1

crankpin positions when a tapered crankshaft is installed. A timing disc and a piston position indicator or a Time-Rite indicator (for Time-Rite information and prices, address Gabb Mfg. Co., 16 Orchard St., East Hartford 8, Conn.) may also be used to position the crankshaft for timing magnetos. The Time-Rite indicator does not require removal of the propeller. It is installed in No.1 upper spark plug hole with the adjustable scale to the rear. Operating instructions are furnished with each Time-Rite instrument. Scales and arms are available for adaptation to most aircraft engines.

10-12.

Using any of the methods of crankshaft positioning mentioned in paragraphs 10-15 & 10-16, install and time the magneto thus:

- a. Remove all upper spark plugs.
- b. Position the No.1 crankpin on its compression stroke and at the proper-advance firing angle. (Refer to Table X.)
- c. Position the magneto distributor at its No.1 firing point, as described in paragraph 10-15 & 10-16.
- d. Work a small quantity of a non-hardening gasket paste into both surfaces of the magneto gasket, and place it on the mount pad.
- e. Install the magneto on its pad, meshing the drive gear with teeth of the crankshaft gear (in -8 models) or camshaft gear (in -12, -14, -16 and O-200 models), and place plain washers, lockwashers, and plain hex nuts on the retaining studs. Tighten the nuts with fingers only, leaving the magneto free to rotate within the limits allowed by the slotted flange holes.
- f. If an AM-4 magneto is being installed, connect the timing light magneto lead to the switch wire stud and the ground lead to one of the mount studs.
- g. If an Eisemann LA-4, Bendix or slick magneto is being installed, place a switch wire terminal assembly and short lead in the magneto terminal opening; screw in the union nut, and attach the timing light magneto lead to the bored end of the short lead wire. Connect the ground lead to a magneto mount stud.

- h. Turn the magneto case in the direction which its drive gear will rotate to the limit of the slots. The breaker points should be closed. Tap the magneto case in the opposite direction until the timing light indicates that the points are just opening.
- i. Check alignment of Bendix or Slick timing marks or Eisemann distributor rotor arm. Tighten the mounting stud nuts to hold the magneto in place.
- j. Back up the crankshaft 8 or 10 degrees. This will not allow the impulse coupling pawl to leave its position under the stop pin. Tap the crankshaft carefully forward until the timing light indicates that the breaker points have just opened. Check the crankshaft or piston position. If it is not correct, loosen the magneto mounting stud nuts and repeat steps hand i.
- k. When the breaker points open at the correct firing angle, tighten the magneto retaining nuts.

10-13. CONNECTIONS

Connect the bared end of the switch wire to AM-4 magnetos by wrapping around the terminal stud at the rear of the distributor housing and tightening the hex nut. The switch wire terminal assembly for Eisemann LA-4 and Bendix magnetos must be assembled on the wire end piece by piece, the coupling nut going on first, and secured by the method provided. Install the terminal assembly and wire before replacing the breaker cover, if the terminal spigot is in the housing, and ascertain that the end of the terminal makes contact with the breaker contact spring.

WARNING

If an insulating strip was inserted under a Bendix magneto switch terminal grounding spring it must be removed before the switch wire terminal is installed. Failure to remove the insulator makes it impossible to ground the primary circuit and creates a hazard to persons working about the aircraft.

Connect spark plug cables to AM-4 magnetos by pushing the terminal clips into the magneto distributor housing sockets. Start by inserting No. 1 plug cable in the marked socket, and continue in the clockwise direction around the cap, inserting Nos. 3, 2 and 4 cables in that order. To connect spark plug cables to an LA-4 magneto, start by inserting No.1 plug wire through the left end spigot of the distributor cable plate (on top), leading it around the left side of the distributor block, and attaching it with a screw to the terminal in line with the timing window. Then, insert No.3 plug cable through the right end cable plate spigot, lead it around the block to the right, and connect it to the next terminal in the counterclockwise direction (at the bottom). Insert the No.2 plug cable through the second spigot from the right, and connect it to the next counterclockwise terminal (upper right). Connect the No.4 cable to the last terminal. If tubular cable terminals are installed on the ignition cables their ends must be pushed up inside the insulation and must not be pulled out when the terminal screws are tightened. Seat the rubber cone bushings in the plate spigots. Make sure that a plain washer is located between each cone and the cable coupling nut. Then, screw the knurled coupling nuts on the plate spigots, and tighten with the fingers. Replace the distributor cover and tighten its two retaining screws. The terminal plates of Bendix cable assemblies need only to be inserted into the distributor housings and retained by installation of the four lockwashers and screws which attach each.

WARNING

Eisemann magnetos are not equipped with grounding springs at the switch wire terminals. No work should be performed on engines equipped with these magnetos while the spark plug cables are connected to installed spark plugs from either magneto until the following points have been checked.

1. The connection from magneto to switch must be completed.
2. The connection from the switch to the engine must be completed.

3. The magneto switch must be in the "OFF" position.

10-14. MAINTENANCE OF EISEMANN AM-4 MAGNETOS

These magnetos have oil-impregnated breaker cams and grease packing bearings. The breaker follower is lubricated by oil held in the cam. Gears are also impregnated with oil. No lubrication between overhauls is required. At periodic inspections the distributor housing may be removed by removal of four screws which attach it to the coil housing. Inspect the interior of the case, and remove any dirt, oil or moisture with a clean lintless cloth. Inspect the condition of breaker points. If they are pitted or burned remove and test the condenser. If the condenser is found to be defective replace it with a new part, and replace defective breaker assemblies. Do not dress breaker points, except in an emergency. For right hand rotation, the "V" mark on the large distributor gear is aligned, at assembly, with the punch marked tooth on the rotor shaft gear. The breaker points are adjusted to open when the rotor has passed its neutral position by the correct edge gap. The breaker cam then provides a full point opening of .019-.021 inch. If a new breaker is installed, or if it becomes necessary to readjust breaker point opening, the breaker follower should be placed on the highest side of the cam, by turning the propeller; then adjust the point gap within the limits mentioned above. Check the adjustment by carrying out the timing procedure check described in paragraph 10-12j, without loosening the magneto retaining nuts. If the magneto was correctly timed originally, the readjusted breaker will open at the specified advance firing angle.

NOTE

The propeller must be turned backward to the firing position to prevent engagement of the impulse coupling pawl.

10-15. MAINTENANCE OF EISEMANN LA-4 MAGNETOS

The ball bearings are packed with grease, and the distributor bearing and breaker cam are both oil impregnated, therefore no lubrication between overhauls is required. Do not wash the breaker cam or wipe it with any petroleum solvent. During periodic inspections the magneto breaker should be

inspected. To gain access to the breaker, remove the two screws which attach the cable plate (on top) to the end plate. These are the two front screws in the group of four. Remove the three screws which attach the adapter to the end plate; then carefully remove the adapter and cable plate assembly, bending the spark plug cables, and allow it to hang to one side. Clean the inside of the distributor block with a clean lint-free cloth, and inspect the carbon brush and spring. Check to see that they move freely in the socket and that the brush extends beyond the socket. The high tension spring assembly on the distributor block should be free on the high tension pick-up post. Inspect visually for dirt on the contacts. To check the breaker adjustment, turn the crankshaft until the breaker follower rests on the highest point of the cam. Insert a thickness gauge between the points. The gap should be .018-.022 inch. If the gap is not within these limits, slightly loosen the two breaker fastening screws, and adjust by means of the eccentric stud. Retighten the fastening screws, and check the gap. When this operation has been finished, it will be necessary to recheck timing of the breaker point opening to No.1 piston. Inspect the contact of the switch wire terminal with the breaker contact spring.

CAUTION

Do not lift the movable breaker point to produce an opening of over 1/16 inch when inspecting points.

10-16. MAINTENANCE OF BENDIX S4RN-21 AND S4-LN-21 MAGNETOS.

Ball bearing of these magnetos are packed, at assembly, with grease, and the distributor bushing and breaker cam are impregnated with oil. No lubrication need be applied between overhauls. If engine operating troubles appear to be caused by the ignition system, it is advisable to check the spark plugs and cables for defects before opening the magnetos. If ignition trouble is traced definitely to a magneto, the safest procedure is to replace the defective unit with a new or rebuilt assembly and to send the original magneto to the overhaul shop for complete rebuilding and test. If this should be impossible, a visual inspection may disclose a minor trouble which can be corrected in place.

Remove the high tension cable outlet plate. Inspect the contact sockets in the distributor block for moisture. Remove any condensation with a lintless cloth. Remove the four cable contact screws at the front side of the rubber outlet plate grommet. Remove the washers, and slide the grommet from the cable ends. Inspect the interior of the grommet sockets for moisture and dry thoroughly. Remove any moisture from the cables. Replace the grommet, and secure it with the cable contact screws. If no moisture was found, remove the hex head plug from the top of the case, and turn the crankshaft backward until the white gear tooth aligns with the timing mark or pointer. The breaker points should be just opening. If they do not, loosen the screw in the breaker slotted hole, and shift the breaker until the points just separate, as indicated by a timing light connected across them. Recheck timing, as in paragraph 10-12j, without loosening the magneto retaining nuts. Remove any oil from the breaker points with a small cloth dampened in clear gasoline. Avoid wetting the breaker cam. If breaker points are burned, replace the condenser and the complete breaker.

10-17. SLICK MAGNETOS

Like the Bendix this magneto has no set breaker point clearance. A timing gauge key is used to lock the rotor in the position at which the contact points just open.

10-18. REPLACEMENT OF IGNITION CABLES

10-19. UNSHIELDED CABLES

If only a single cable has been damaged a replacement may be made up of component parts. The number and type of terminal parts will depend on the type of magneto installed. This information will be found in the parts catalog. Since cables for Eisemann magnetos are individual complete assemblies, they are supplied separately, by part number, for the various locations, with proper terminals and ready for installation. Since unshielded cables for Bendix magnetos are assembled into the cable and plate assemblies, they are not supplied separately. Replacements for Bendix - equipped engines may be made of bulk cable by cutting it to the same length as the original and installing a spark plug safety lock terminal. The magneto end may be threaded through the bracket grommets from which the old cable was removed. The old cable may be detached from the high tension outlet plate grommet by removing the plate attaching screws, pulling the plate and grommet assembly

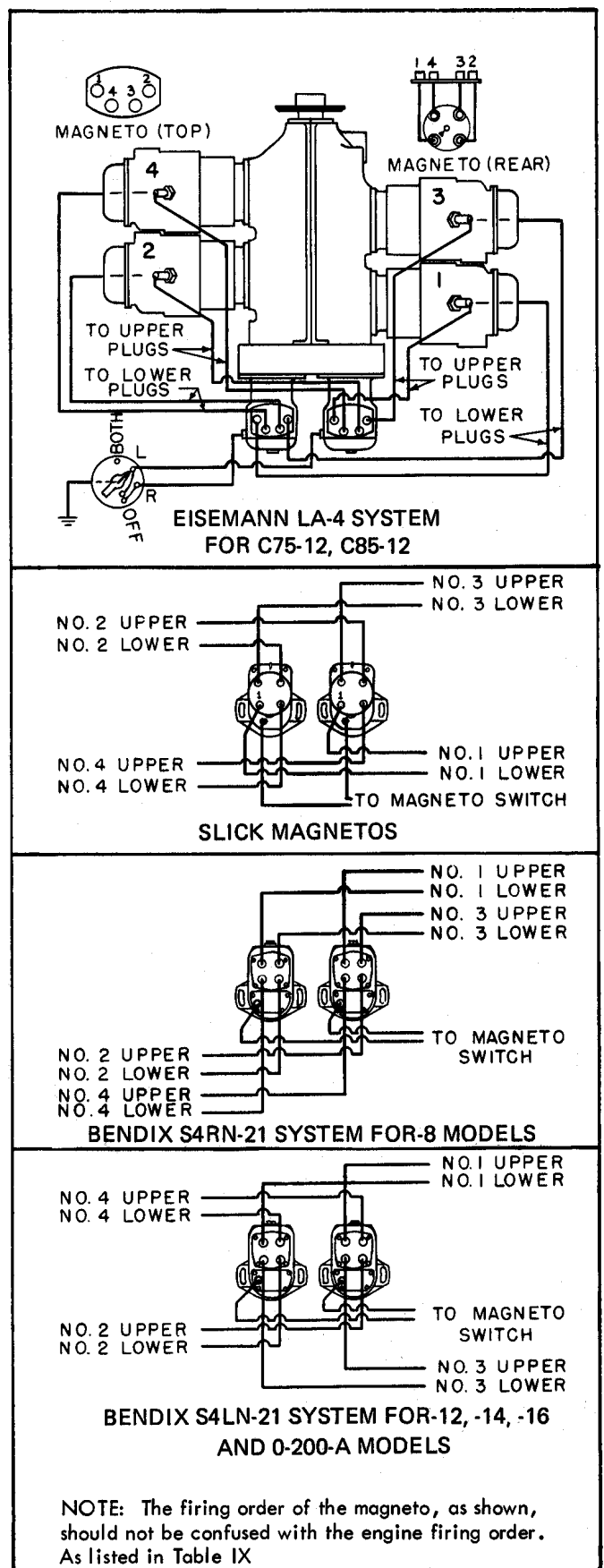

Figure 17. Ignition Wiring Diagram.

carefully from the magneto, and removing the cable piercing screw installed in the cable end. The magneto end of the replacement cable must be cut off square. Insert it into the grommet through the outlet plate hole; place a washer on the front end of the grommet boss, and insert the cable piercing screw so that it will enter the copper conductor and divide the strands. To install a replacement cable in an AM-4 magneto system, it is necessary only to pull the old cable from the magneto terminal socket, disconnect the spark plug terminal, and pull the assembly from the brackets. A new cable assembly may be replaced in the reverse order.

10-20. SHIELDED IGNITION CABLES

While it is possible to fabricate a replacement radio shielded cable assembly for either Eisemann LA-4, Bendix or Slick magnetos, the length of time required for the work and the possibility of unsatisfactory results make the undertaking inadvisable, except in emergencies. As a rule, if one cable in a shielded ignition system breaks down under a high voltage test, the others should also be considered hazardous, and the entire assembly should be replaced.

10-21.

Radio shielded ignition cable assemblies for upper right, upper left, lower right and lower left spark plugs and Eisemann LA-4 magnetos are supplied with brackets and terminals installed, so that any of the assemblies may be installed on -12 and -16 models by removing the contact elbows of the old assembly from the spark plugs, detaching the cable brackets from the crankcase studs, removing the magneto cable terminals, as described in paragraph 10-19, attaching the new assembly brackets and spark plug elbows and installing the magneto cable terminals, as outlined in paragraph 10-19. If replacement is due to mechanical damage of one or two cables, only the assembly affected need be replaced, but if the old cables leaked under a high voltage test, the complete system, consisting of four cable assemblies, should be installed. (Refer to diagram, Figure 17.)

10-22.

For model O-200 engines and either of the -8, -12, -14, or -16 models equipped with Bendix magnetos, the radio shielded ignition system consists of the

two magnetos and a cable and plate assembly for each plus two ground terminal kits, with which to make up the switch wire terminal assemblies. If the dielectric qualities of any cable have been reduced so that a break-down under high voltage occurs, both cable and plate assemblies should be replaced. They are obtainable under a single part number, or each cable and plate assembly may be purchased separately. Bulk cable and other component parts may be purchased for repair of mechanical damage. To replace a cable and plate assembly on a Bendix-equipped engine, remove the old cable elbows from spark plugs, and detach the old cable brackets from crankcase and crankcase cover studs; then remove the four retaining screws from the high tension cable outlet plate, and carefully pull the plate and grommet from the magneto case. Attach brackets of the replacement cable and plate assembly to the engine studs, and install the new cable contact sleeves and elbows on spark plugs. Carefully insert the new plate and grommet in the magneto in the only position in which screw holes will align. Install the plate retaining screws and lockwashers.

NOTE

Make sure that the correct cable and plate assembly is used. The sequence of cable numbers around the high tension cable outlet plate differs in assemblies for -8 models from that of assemblies for -12, -14, -16 and O-200 models. (The latter four are identical.) Assemblies for -8 models have only one straight bracket on each pair of upper and lower cables, while those for -12, -14, -16 and O-200 models have an additional (twisted) bracket on each pair. (Refer to the wiring diagram, Figure 17.)

10-23.

In an emergency, a single radio shielded cable may be made up of bulk shielded cable and terminal parts. Remove terminal parts from the original; cable, and observe how the outer covering and shielding braid are stripped back and the braid turned into a cuff under the spark plug elbow lead cone and under the magneto and flanged ferrule. Duplicate lengths of cable and stripping. The ferrule must be swaged onto the cable over the braid cuff, in order to hold the cable firmly to the magneto. The job should not be attempted unless a swaging

tool is available. Other operations require only the usual hand tools. Lengths of the stripped cable ends and of the bared copper strands must be accurate. Swage the ferrule on the magneto end so that the braid cuff (3/16 inch long) is centered under it. Cut the magneto end to final length after the ferrule is swaged in place. Then, cut the cable to correct overall length. For LA-4 magnetos, bare the magneto end, and install a tubular Eisemann terminal, pushing it 1/8 inch into the insulation and bending it to a hook, or wrap the bare strands around an eyelet, and form the straight eyelet tube end into a second flange like the preformed end. Then, push a rubber cone bushing over the eye and up to the ferrule flange. For Bendix magnetos, cut off the stripped magneto end cable insulation and copper strands to final length and square after swaging the ferrule in place. Cut the cable to overall length. For either type of magneto, run the appropriate coupling nut on over the spark plug end. Spark plug ends of all cables are the same. Slide the elbow coupling nut on; then place the lead cone over the braid cuff, and push the stripped cable end through the elbow. Screw the coupling nut on the elbow. Strip the high tension insulation hack from the cable end about 1/8 inch; twist the strands of wire, and install a contact sleeve. Make sure that the sleeve seats on the elbow; then spread the wire strands and bend them over the sleeve eyelet. This completes the cable. To install it, the bracket rivets must be sheared and the tape removed. Rewrap the replacement cable with the mate, using 3/4 inch friction tape, and re-rivet the brackets to hold the pair of cables securely.

10-24. DELCO-REMY STARTER

10-25. REMOVAL

Disconnect the cockpit control from the starter clutch shift lever, which is pivoted on the right side of the motor housing. Unscrew the hex nut on the starter switch terminal post, and remove the electric power cable. Insulate the cable end. The starter is attached to its aluminum adapter plate, which also supports the pinion and clutch assembly. This assembly must be removed, as a unit, by removing the lockwashers, plain washers, then the three plain hex nuts, which attach the round part of the adapter to crankcase cover studs, and the two through bolts installed from the front side of the upper extensions of the crankcase rear flange. When these five

attachments have been removed the starter will be free, except for possible adhesion of the gasket. Tap the motor housing with a non-marring hammer or bump the motor housing with a non-marring hammer or bump it with the hand, if necessary, to break loose the gasket. The starter clutch is piloted on the pivot head in the crankcase. Slide the assembly straight to the rear until the clutch and pinion clear the pivot.

10-26. INSTALLATION

Coat the starter pinion pivot and the starter pinion and gear teeth with the engine oil. Apply a thin film of non-hardening gasket paste to both surfaces of a new starter gasket, and install the gasket on the crankcase cover pad, making sure that all old gasket material has been removed. Examine the mounting surface of the starter adapter for cleanliness, and wipe it dry. Keeping the clutch assembly back against the adapter, start the pinion over the end of the pivot. Hold the starter and clutch assembly in line with the pivot as it is moved forward. The pinion will not mesh, and the adapter should seat firmly on its gasket without interference. Install three plain washers and three lockwashers on crankcase cover studs and a plain washer and lockwasher on each through bolt. Run on the three plain hex nuts, and install the two bolts through the crankcase flange and cover. Tighten the bolts and nuts evenly to prevent warping the adapter plate.

10-27. ADJUSTMENT

It is very important that the control cable return spring have sufficient tension to hold the starter shift lever in the fully released position. There must be at least 1/16 inch clearance between the clutch shaft end and the shift lever end when the control is released. The shift lever switch contact screw must be adjusted to allow 9/16 inch clutch travel from the released position to the fully engaged position. The last 1/8 inch of clutch movement is made while the shift lever screw is compressing the switch button. When the screw has been adjusted to fulfill these requirements, tighten its lock nut. To check the adjustment, turn the propeller so that the minimum clutch travel is now obtained. The pinion and crankshaft gear teeth are now abutted. The clutch must move from its released position to touch the crankshaft gear, so that there will be a clearance when the control is released. Actuate the control,

and determine, by inserting a screwdriver into the clutch shaft end and pushing forward, that the spring cap can be moved at least another 1/16 inch to assure that the switch is making contact.

WARNING

Before starting any work on the electric starter or generator, make sure that both the ignition switch and the master switch are in the "OFF" position.

10-28. MAINTENANCE

The starter commutator and brushes, visible when the brush cover band is removed, should be inspected periodically for cleanliness. Adjustment of the shift lever should be checked at periodic inspections, however this will need no alteration, unless the adjustment was incorrectly made previously. No lubrication is required between overhauls. An oilite bushing in the clutch bore for the pinion pivot and another in the clutch shaft hole in the adapter provide lubrication for the exterior bearings, and the gears are lubricated by engine oil. If any repair or disassembly is necessary, the starter assembly must be removed from the engine.

10-29. PERFORMANCE DATA

The starter armature rotates counterclockwise, as seen from the drive end. Correct brush tension is 24-28 ounces. With no load, the armature turns 7000 R.P.M. when the drop across its terminals is 11.25 volts. The current draw is then 75 amperes. On blocktest load it should develop 18 ft. lbs. torque at 6.1 volts, with a current draw of 590 amperes.

10-30. PRESTO LITE STARTER

10-31. REMOVAL

Unscrew the hex nut on the starter switch terminal post, and remove the electric power cable. Insulate the cable end. The starter is attached to its aluminum adapter plate, which also supports the clutch assembly. Remove five sets of nuts and washers and two bolts which are installed from the upper front side of the crankcase. It may be necessary to tap the adapter with a plastic hammer, or bump it with the hand to break loose the gasket adhesion. Be careful when removing the starter that the clutch assembly does not drop.

10-32. INSTALLATION

Lubricate the starter pinion and intermediate gear and install on starter adapter. Hold the starter assembly in position to align the clutch bore with the crankcase pivot and push the clutch over the pivot, holding the assembly in line as it approaches and seats in the pad. Install the nuts and washers on the studs. Insert the two bolts and secure with washers and nuts. Torque to value specified in Table of Limits.

10-33. ADJUSTMENT

See appropriate airframe manual.

10-34. MAINTENANCE

The starter commutator and brushes, visible when the brush cover band is removed, should be inspected periodically for cleanliness. Brushes must be replaced when they have worn down to a length of 1/4" or less.

10-35. PERFORMANCE DATA

The correct brush tension with new brushes is 32-40 ounces. Measure with a spring scale hooked under the spring at the brush. Pull on a line opposite the line of force exerted by the spring and take the reading just as the spring leaves the brush. With no load the armature turns at 8000 RPM when the drop across its terminal is 10.0 volts. The current draw is 50 amps max. On a stall torque test it should develop 11.1 min. ft. lbs. at 4.0 volts with a current draw of 560 amps.

10-36. PRESTOLITE STARTER CLUTCH OVERHAUL

Complete overhaul of the Prestolite starter clutch assembly can be accomplished with repair kit PIN 639297, using tools supplied in tool kit PIN 639298. The following instructions and dimensional information is to be used in conjunction with the procedures included with the repair kit.

1. Inspect the inner race sprag and needle bearing diameters of the shaft portion of the large gear. If either of these areas are scored or pitted, replace the part. Needle bearings should be replaced if they have more than 500 hours service. Measure for wear to the following limits:

- a. The dimension at the needle bearing area for a new part is 0.4997-0.5000. Service limit is 0.4995.
 - b. The dimension at the inner race sprag area for a new part is 0.5772-0.5777. Service limit is 0.5769.
2. Inspect the outer race of the sprag housing. Any "washboard" pattern is cause for replacement of the sprag housing and gear assembly. Measure the outer race diameter for wear.
 - a. The dimension of the outer race for a new part is 1.0734-1.0739. Service limit is 1.0743.
 3. Inspect sprags for pitting or worn flats.

10-37.

When assembling the sprags, coating the inner race of the sprag housing with a bearing grease will help hold the sprags in place around the inside diameter in the proper direction (see figure 17-1) and install one spring at the housing end. Then insert the mandrel from the gear end and proceed as follows:

NOTE

When assembling the PIN 634461 starter clutch adapter in the crankcase, be sure to use the new hardened dowel, PIN 637832. Also, check for proper tolerance between the adapter and crankcase bore, which should be 0.001 T to 0.001L. This tolerance is critical.

1. Remove outer snap ring (1, figure 17-2) and washer (2) from end of inner race (3). Discard snap ring.
2. Remove inner race (3) from outer race assembly (4) by a slight rotation of inner race in the over-running direction (clockwise). Remove needle bearing.
 - a. Remove inner snap ring (5) and washer (6). Discard snap ring.
 - b. Examine inner race sprag and bearing diameters.
3. Insert mandrel (7, figure 17-3) from needle bearing end.
 - a. Push sprags out of outer race assembly (4, figure 17-2) approximately 3/8-inch.
 - b. Wrap sprags with rubber band onto mandrel.
 - c. Remove spring (8) and discard.
 - d. Remove sprags from outer race. Sprags should remain on mandrel.
 - e. Inspect bearings and outer race sprag diameters. If bearings or outer race sprag diameters show a "washboard" wear pattern, replace the sprag housing and gear assembly.
4. Insert inner race (3, figure 17-4) into sprags replacing mandrel (7).
 - a. Remove spring (9) and discard.
 - b. Install new spring.
5. Insert mandrel (7, figure 17-5) into sprags replacing inner race (3).
 - a. Install sprags in outer race. Remove rubber bands.
 - b. Install new spacer (10) between sprags.
 - c. Install new springs (11).
 - d. Install washer (6) and remove mandrel and install new inner snap ring (5).
6. Install inner race (3, figure 17-6) into sprags by gently pushing and turning in over-running direction (clockwise).
 - a. Locate bearings on inner race end and push in with mandrel (12) until flush with end of outer race (4).

- b. Install end washer (2) and new snap ring (1).
- c. Check for smoothness and correct rotations.

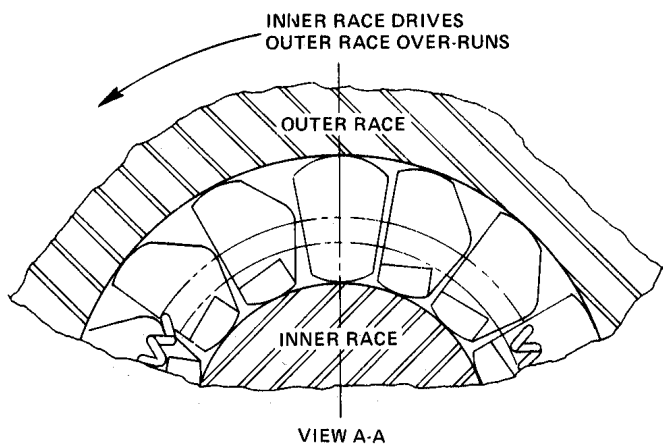

VIEW A-A

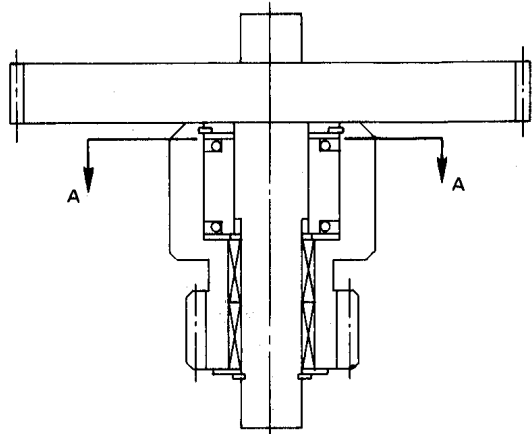

Figure 17-1

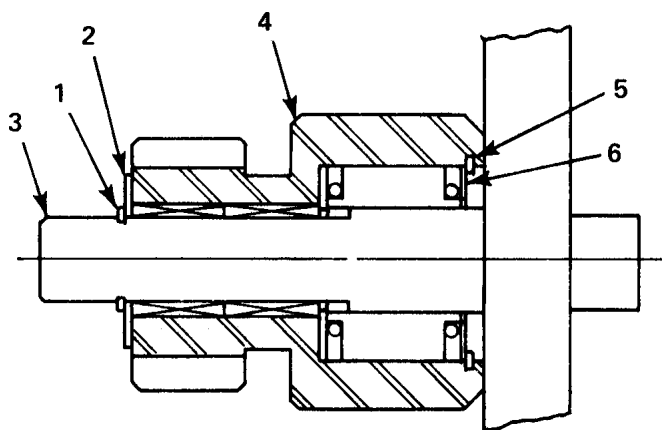

Figure 17-2

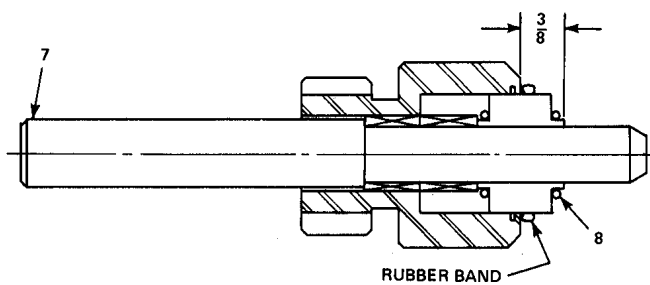

Figure 17-3.

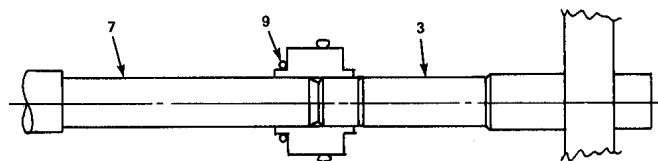

Figure 17-4

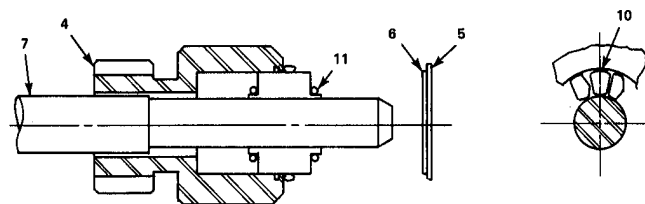

Figure 17-5.

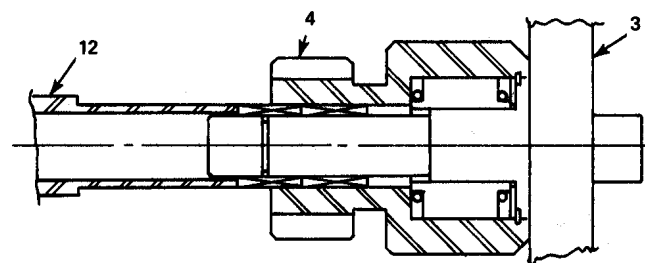

Figure 17-6

10-38. GENERATOR/ALTERNATOR AND DRIVE

10-39. REMOVAL

Before removing the generator and drive assembly, disconnect the tachometer drive conduit and pull the cable end from the engine drive shaft. Inspect for oil leakage into the tachometer drive conduit. If leakage is observed, a new oil seal should be

installed in the tachometer drive housing when it is off the engine. Remove the three elastic stop nuts and plain washers, and pull the tachometer drive housing from the shaft. Disconnect both electrical wires from the generator terminals. Remove the three elastic stop nuts which retain the generator and the three plain washers, and pull the unit straight to the rear. Remove all gasket material from the mount pad and generator flange.

10-40. DISASSEMBLY OF DRIVE

Remove the cotter pin from the end of the generator shaft, and unscrew the drive retaining nut. The gear, sleeve (if installed), bushings (or old type rubber drive disc) and retainer will slide off the shaft easily. Use a gear puller to remove the coupling hub. The woodruff key may be lifted by tapping on its outer end with a hammer and screwdriver very carefully. The oil seal may be removed from the counterbore in the generator drive end frame with some type of bearing race puller, or it may be pried from the recess by cutting two holes in the rolled edge of the seal case with a small, sharp chisel and prying on opposite sides against wood blocks set on the flange. Present generator shafts are equipped with an "D" ring seal installed between the bearing and coupling hub. Remove and discard the "D" ring seal.

10-41. TYPES OF DRIVE

Three types of drive assembly have been produced at various times. The earliest type included a single piece rubber drive disc without a retainer and the gear fit directly on the generator shaft. The second type of drive in production had a steel retainer to prevent spreading of the rubber drive disc, and the gear, disc and retainer were centered on a steel sleeve which was held against the coupling hub by the shaft nut, leaving the gear a free fit to avoid compression of the rubber drive disc. The latest type of drive assembly is similar to the second type, however the rubber cushioning member is now composed of two bushings, instead of the slotted disc, and the drive gear lugs extend to the rear side of the bushings, not quite touching the surface of the bushing retainer, but contacting the full bushing face. This arrangement prevents any possibility of shearing the rubber member. If the drive gear is serviceable and single piece discs still available, the second type of drive may be continued in service,

though the latest type is preferable. The original drive without disc retainers, should not be reinstalled.

10-42. REASSEMBLY OF DRIVE

If groove is machined in the generator shaft adjacent to the bearing, lightly coat an "O" ring seal with engine lubricating oil and install it in the groove. New generators are not sold without oil seals. Coat the lip of the oil seal with Gredag No. 44. Center the seal in the generator recess with the seal lip outward. Tap the seal case squarely into the recess. Tap a woodruff key into the shaft slot. Slide the coupling hub on the shaft, and align its key slot with the woodruff key. Drive the hub over the shaft shoulder and key until its rear end seats against the shaft bearing shoulder and over the "O" ring seal. Slide the steel sleeve over the shaft end, then the pressed steel retainer. Place either two new type rubber bushings or a rubber drive disc, depending on the gear type, in the retainer. Place the drive gear on the sleeve, and engage its lugs in the bushing or drive disc slot. When pressed back firmly by hand, the front end of the gear hub should lie slightly to the rear of the sleeve end, and the end of the steel sleeve should be slightly ahead of the shaft front shoulder, so that the nut flange will bear on the sleeve, but not on the gear. Tighten the shaft nut, and install a cotter pin to retain it. If the cotter pin hole and nut slot cannot be aligned without excessive tightness or looseness of the nut, select and try another nut. (Refer to Section XVIII.) Test for flexibility between the coupling hub and the gear.

WARNING

Do not install a gear with short lugs, for the single piece rubber disc, in combination with two new type rubber bushings. Disintegration of the rubber, caused by insufficient contact area, may allow bits to plug the suction oil screen or an oil passage hole, with consequent failure of all or part of the lubrication system.

10-43. INSTALLATION

Coat the generator and tachometer gasket with a thin film of non-hardening gasket paste and position

it in place on the crankcase cover. Replace the tachometer housing oil seal if the leakage is indicated. To prevent cutting the seal lip place a strip of fiber or wood in the drive shaft slot. The protective strip must fit exactly and have a curvature corresponding to that of the shaft surface. Apply Neates Foot Oil to the lip of the seal and install the tachometer drive housing on the crankcase cover. Secure the housing with three new elastic stop nuts and washers. Remove the protective strip from the shaft slot.

NOTE

Older engines have drilled studs for slotted nuts to retain the tachometer drive housing. Do not use elastic stop nuts with these.

10-44.

Install the generator and drive assembly on its mount pad, meshing the drive gear with the camshaft gear internal teeth as it moves into position. Install three plain washers and elastic stop nuts on the cover studs to retain the generator assembly. Tighten the nuts evenly. Check gear backlash by inserting two fingers through openings near the drive end and attempting to rotate the armature. There must be a slight backlash to prevent shaft breakage. Attach the wire from regulator terminal marked "GEN" to the generator armature terminal, marked "A". Connect the wire from the generator field switch or master switch to the generator field coil terminal, marked "F".

10-45. MAINTENANCE

The generator armature bearings are grease packed and shielded. They require no lubrication between overhauls. The drive gear is lubricated by engine oil. At periodic inspections the brush cover and vent tube assembly may be removed by loosening the clamp screw, and the commutator and brushes may be inspected for cleanliness. The performance of the generator will indicate its electrical condition, and its mechanical condition may be considered satisfactory unless overheating or noise or sudden stoppage point to damage of one of the few moving parts. Any disassembly or repair work must be performed after removal from the engine.

10-46. PERFORMANCE DATA

The generator armature rotates in the clockwise direction, as seen from the drive end. The unit is designed for operation in a battery charging circuit in which the battery negative terminal is grounded. For proper performance, the air blast directed through the vent tube must provide a minimum air pressure differential across the generator of 1-1/2 inches of water column, by manometer test. Brush spring tension should be 24 ounces. For early 12 volts -12 amperes generators the field current draw at 12 volts is 1.62-1.69 amperes. Output at 3650 R.P.M. at operating temperature is 13 amperes at 15 volts. For the current 12 volts -20 amperes generator the field current draw at 12 volts is 1.58-1.67 amperes. Output at 4100 R.P.M. at operating temperature is 20 amperes at 14 volts. Cruising speed range for either generator is 4000-4900 R.P.M. Maximum output is regulated by a current and voltage regulator.

10-47. HYDRAULIC VALVE LIFTERS

10-48. TYPES OF FAILURE

In general, there are four types of trouble which affect valve lifter operation, only two of which are caused by the lifter assemblies. The indications and causes of these troubles may be described as:

- a. Slight single or multiple noise, if caused by the valve lifters, is due to either a leaky check valve or excessive clearance between the hydraulic plunger and cylinder. Either fault will prevent the unit from maintaining zero lash in the valve train, though the resulting clearance and shock noise are small. The same symptom may indicate faults in parts of the train other than the lifters, since any binding or imperfect seating of the valve or wear in the moving parts which would increase the "deflated" lash beyond the limit specified in The Table of Limits would make it impossible for the lifter to compensate for the shrinkage in total train length.
- b. A single, loud "tappet noise" is usually caused by sticking of the plunger in the bore of the hydraulic unit cylinder. This may be due to a gummy deposit or to formation of a ring of carbon above the shoulder of the plunger. Either trouble will cause the plunger to be held down in the cylinder and will prevent it from compensating for cylinder expansion, thus

allowing a large lash in the train. Since the full lash occurs only when the engine is at operating temperature, it is difficult to locate the troublesome lifter by any visual means, though it may be possible to feel the lash immediately after the engine is stopped. With the engine running, a listening rod may be used to compare the noise level of all cylinders and to locate the faulty one. Then, it is a matter of eliminating one of the two lifters of that cylinder. If one unit is stuck because of oil varnish or carbon, it is probable that the others are approaching the same state and all require attention.

c. General "tappet noise" is nearly always an indication that insufficient oil is reaching the hydraulic units. This starvation may be caused by anyone, or a combination, of the following:

1. Hydraulic Units installed without oil. In order to check "deflated" lash in the valve train, it is necessary to install the lifters in a completely dry condition. If hydraulic units are removed from an installed engine, oil will inevitably drain from the reservoirs. (See Figure 8.) Unless other trouble is present, the lifters will fill within 45 seconds of running at warm-up speed.
2. Oil supply running low. If the oil supply level is lowered until the oil pump can suck in air, it will not pick up oil, and continued running will result in complete engine failure. Usually, the valve lifters will give a warning by intermittent noise as air is fed in with the oil a short time before complete failure occurs.
3. Air leak on suction side of pump. The effect is the same as that due to low oil supply, and the result may, or may not, be as rapid and as serious. A defective copper-asbestos gasket between the oil suction tube hex and the crankcase cover will allow a small leakage of air without increase. Failure to tighten or safety the suction tube at assembly may allow it to

loosen progressively. A crack, caused by dropping or other shock, can develop in the crankcase cover oil suction passage wall, allowing a constant air leakage. Warp in the oil pump cover can have the same effect.

4. Solid particles in the oil, after long use, may be fine enough to pass the oil screen and plug or restrict passages to the lifters. Under some conditions, rapid formation of large flakes of carbon can coat the oil screen and cause it to be collapsed by pump pressure, admitting the solid matter on its surface to the oil system. Partial starvation or abrasion may cause the hydraulic unit plungers to stick down in the cylinders, causing a load noise.
- d. Overheating and low power, if not the result of low oil supply or a lean fuel-air mixture, may be caused by subnormal valve lift. Failure of the lifter to rotate leads to grooving of its cam follower, causing excessive friction and possible cam wear. In early stages, this may not affect lifter compensation of noise, however, a reduction in travel will eventually prevent intake of oil to the lifter reservoirs, causing starvation.

10-49. INSPECTION BEFORE REMOVAL

If valve lifter faults are suspected because of noise, the quantity and quality of engine oil should be checked. If a loud single noise was heard, remove the rocker cover of the cylinder affected, and test by pushing on the socket end of each rocker arm. If lash is found in the train, the lifter is definitely inoperative. Inspect valve stems for battering; inspect rocker contact surfaces, and look for broken valve springs. If the tappet noise was not loud, and if it was continuous, the cylinder or cylinders affected should be removed, and the pushrods and rockers should be inspected for wear, as well as the lifters. If the noise was intermittent the sump should be removed and the suction tube and gasket checked, provided that oil condition is good.

10-50. REMOVAL

Remove spark plug cable terminals and plugs of the cylinder affected, and turn the crankshaft to T.D.C. of that cylinder on its compression stroke. Remove hose clamps, and push the pushrod housing rubber connectors back on the housings. Remove palnuts and cylinder base nuts. Withdraw the cylinder and pushrods, catching the piston as it comes free. Inspect pushrods and rocker sockets for wear, and replace serviceable pushrods in their original positions. With a bent wire, hook lifter socket and remove it. (See Figure 18.) Similarly, remove the hydraulic unit. If it tends to stick and the plunger comes out alone, turn the crankshaft until oil pressure forces the cylinder out far enough to be grasped. Test the lifter body for free movement in its guide, and inspect the cam lobe and the follower for wear and scoring.

10-51. CLEANING AND TESTING HYDRAULIC UNITS

Wash the unit in clean petroleum solvent. Twist the plunger to wind up the spring while pulling outward to remove it. If the plunger appears to be stuck, insert a hard wood stick into the inlet tube to release the check valve, and push the plunger inward. If it was held only by a ring of carbon it will slide in freely as the oil drains. The ring can be broken by twisting the plunger and pulling outward with taped pliers (See Figure 20) or, in stubborn cases, by use of a carbon solvent. Wash the separate parts thoroughly in clean solvent, and dry them with dry compressed air. Start the plunger into the upright cylinder; push it down, and immediately release it. If the valve is seating and the plunger fits the cylinder correctly, the plunger will kick back. If it does not the valve may be leaking or the plunger may be excessively worn. Check the plunger fit by sealing the inlet tube with a finger and pushing the plunger inward momentarily. If it does not kick back the clearance is too great. If it does, either the valve seat is dirty or it is worn out of round. Wash the cylinder again to remove possible dirt, and repeat the first test. If the plunger still does not kick back discard the unit. In handling hydraulic lifters,

remember that cleanliness is essential. Also, no grinding, lapping or interchanging of parts is permissible. No shellac, paste or gum may be allowed to reach the units. The plunger must be free in the cylinder, and the check valve must not leak appreciably. For more exact testing, when suitable equipment is available, reassemble the unit by releasing the check valve and installing the plunger, twisting it to wind up the spring until it snaps into the cylinder recess. Hold the inlet tube in clean kerosene, and pump the plunger to fill the adjusting chamber. Place the unit in the fixture, and load the plunger with a force of 50 lbs. The check valve should not leak more than one drop of kerosene per second, nor should the plunger move more than 1/16 inch per second. Some fixtures are designed to test units against a master unit for leak-down rate. These will provide an accurate test of serviceability.

10-52. INSTALLATION AND TEST

Install serviceable hydraulic units in the two lifters of the cylinder, and place the pushrod sockets on the plunger ends. The units should be completely dry to test for mechanical clearance in the valve train with deflated lifters. With the piston at T.D.C. of its compression stroke, stagger the piston ring gaps; compress the rings, and reinstall the cylinder. Push the pushrod housing connectors onto the adapter spigots, and tighten the hose clamps. Push each rocker socket end inward, in turn, to compress the hydraulic unit spring, and measure the clearance between rocker and valve stem with a thickness gauge. (Refer to the Table of Limits for clearance limits.) If the clearances are within limits reinstall rocker covers, sparkplugs and cable terminals. Turn the propeller by hand a number of revolutions to fill the lifters as much as possible before starting the engine. If the trouble has been eliminated, the lifter noise should stop after a short period of running at warm-up speed. Do not increase speed until the lash has been adjusted to zero by displacement of air in all lifters.

SECTION XI

DISASSEMBLY

11-1. PRELIMINARY OPERATIONS

11-2. FIXTURES

The engine should be mounted on a work stand which can be moved over the floor and which has a rotating bed to permit the engine to be held with crankshaft either vertical or horizontal. In the latter position, the crankcase 2, 4 side should be downward. A wood fixture should be available to support a cylinder in such a way as to prevent the valves dropping during disassembly of the subassembly. Another fixture will be needed to hold the crankshaft by its propeller taper or flange during removal of connecting rods. A parts rack, on which to store all disassembled parts of one engine, will prevent mixing. Suitable racks for parts of which more than one are installed, and which must not be interchanged, should be at hand and should provide for separation and identification of the multiple parts.

11-3. STARTER AND GENERATOR

Remove these accessories before washing the engine. The starter may be removed after the two through bolts and three plain nuts, lockwashers and plain washers which attach its adapter are taken off. Pull the assembly straight to the rear. The generator may be freed by removing its three retaining nuts. If gasket adhesion makes removal of either accessory difficult, do not pry. Bumping with the hand will loosen them.

11-4. PRELIMINARY CLEANING

The engine assembly should be sprayed and brushed with a petroleum solvent to remove all caked dirt and oil, particular attention being given to attaching parts. To reduce oil drainage during disassembly, it is advisable to remove rocker covers, oil sump and oil suction tube during this operation.

11-5. IGNITION SYSTEM

Remove spark plug cable terminals from the plugs. Detach cable brackets of shielded systems from case studs. If Eisemann AM-4 magnetos are installed the unshielded cables may be pulled from

the magneto sockets and threaded through the brackets to remove them individually. If Eisemann LA-4 magnetos are installed, the cables should be removed with the magnetos and disassembled later. Bendix or Slick cable outlet plates may be detached by unscrewing the screws which attach each plate to the magneto. Pull the plate and grommet carefully from its position. Remove all spark plugs. Remove two nuts retaining each magneto, and withdraw it to the rear.

11-6. LOCKING PARTS

It may be found expedient to remove all cotter pins, lockwire and palnuts before proceeding with disassembly. If not, then the locking parts should be removed completely and discarded before attempting to loosen nuts and screws. Make sure that no lockwire or cotter pin fragment remains in a stud hole to bind the nut.

CAUTION

Always remove the palnut before applying the wrench to the plain nut under it. If this procedure is not followed, an attempt to remove both nuts at once may back out the stud.

11-7. FUEL PUMPS

Detach the delivery tube between dual pumps, if both are installed. The side pump is detached by removing the two flange retaining nuts. Spring force on the lever will tend to cock the pump and must be resisted to prevent binding on studs. Detach the lower pump from its adapter studs in the same manner. The adapter will be free when the four nuts are removed from mount pad studs. Keep the pushrod with the adapter.

11-8. CARBURETOR AND AIR INTAKE HOUSING

Detach the air filter by turning the four locking studs to the left, and remove the gasket with it. Detach the intake housing by removing four slotted nuts or plain nuts and lockwashers from

carburetor lower flange studs. Similarly, detach the carburetor from the manifold.

11-9. AIR SCOOP

Remove the air filter and gasket by turning the four locking studs to the left and withdrawing. Detach the scoop by removing two slotted nuts and cotter pins inside the scoop. Remove cotter pins from throttle link rod ends, and remove the rod assembly from the throttle levers.

11-10. DISASSEMBLY

11-11. NON-REUSABLE PARTS

All lockwire, cotter pins, palnuts, lockwashers, elastic stop nuts, gaskets, oil seals and synthetic rubber parts must be discarded in such a way as to avoid the possibility of reuse. The nature and functions of these parts make it unwise to trust their reliability, once they have been removed.

11-12. OIL SUMP AND SUCTION TUBE

Loosen and run off the six castle nuts or elastic stop nuts which attach the sump flange to the case. Remove the slotted or elastic stop nut which attaches the oil filler neck to the case lower mount arm. Withdraw the sump, being careful not to strike the suction tube within. Remove lockwire from the suction tube hex, and unscrew the tube. If an oil cooler is installed remove the cooler from its adapter and the adapter from the crankcase.

11-13. AIR INDUCTION SYSTEM

Loosen all hose clamps, and push hose connectors back to the intake tubes. This frees the tubes. Remove the two manifold retaining nuts, and draw the casting from the crankcase studs squarely. Detach all intake elbows from cylinder flanges by removing retaining nuts and tapping carefully to loosen the gaskets.

11-14. ROCKER COVERS

These are detached by removal of six fillister head screws, lockwashers and plain washers from each, and they may be removed by carefully pulling outward at points around the rims. Careful handling is necessary to avoid distortion and subsequent oil leakage. Prying is not advisable

because of the possibility of scratching the rocker box flange.

11-15. CYLINDERS

It is not necessary to remove rockers and pushrods before the cylinders are removed, however this may be done after pushing out the rocker shaft. Usually, the valve lifters make it difficult to remove the rocker shaft, because the units take up all lash. For this reason, the following procedure is suggested.

- a. Remove pushrod housing hose clamps, and push the rubber connectors outward onto the housings. Do this on all cylinders.
- b. Turn the crankshaft until the piston of the first cylinder to be removed is at T.D.C. on its compression stroke. The order of removal is not important, except to avoid overbalancing the work stand. To minimize crankshaft turning, the order of 4, 1, 3, 2 is suggested. For greatest accessibility, the crankshaft should be vertical and its front end upward.
- c. Loosen and remove the six base nuts; then pull the cylinder outward, and make sure that the connecting rod does not strike the crankcase.

CAUTION

Do not grasp or lift cylinder by pushrod housings. They must not be loosened in the cylinder head.

11-16. PISTON ASSEMBLIES

Remove each piston immediately after its cylinder has been removed and stored in a safe place. If the piston pins have loose fitting end plugs it is advisable to remove the lower one as the cylinder comes off to prevent falling. The loose plugs may be removed to permit insertion of a screw type pin puller. Current production pins with pressed in plugs should not require force to remove unless a heavy varnish deposit has formed. If driving is necessary support the piston against the impact, and use a non-marring drift. Remove and discard the piston rings, spreading each ring as it is removed to avoid scratching the piston lands. Push the pin back into the piston for storage.

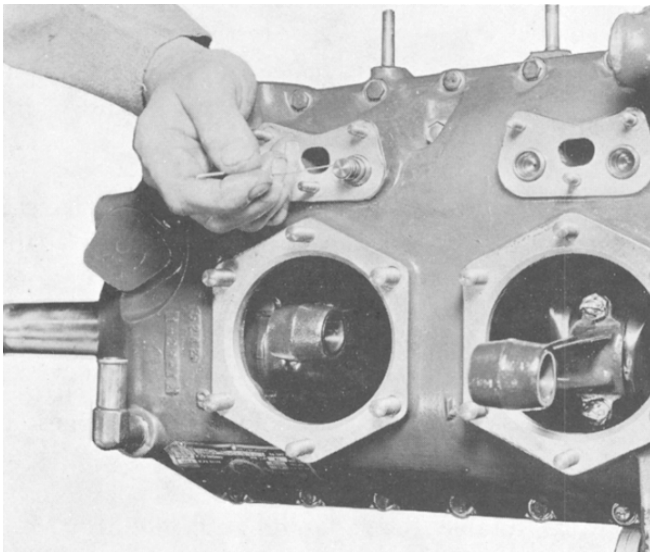

Figure 18. Removal of Hydraulic Unit from Valve Lifter Body.

11-17. PROTECTORS

It is advisable to install on each connecting rod, after removal of the piston, some type of protector to prevent impact on the crankcase chamfer and damage to it. Split pieces of rubber hose, used cylinder base packings and other means may be kept on hand for this purpose.

11-18. CRANKCASE AND COVER

Separate the remaining subassemblies thus:

- a. Remove nuts which attach all pushrod housing adapters to the crankcase, and remove the adapters, tapping carefully to loosen.
- b. In the event that an old style lifter, without a retaining ring, is used, the following procedure should be used. While the crankshaft remains in the vertical position, hook each valve lifter socket, and remove it with a bent wire; then remove the hydraulic units with the wire. Keep unit parts in original pairs. The parts are not interchangeable. Store units to indicate cylinder number and position. (See Figure 18.)
- c. Make a double loop of a cylinder base packing or obtain a rubber band of suitable length to hold each pair of lifter bodies on the 1, 3 side, and pass the loop around their outer ends. This will prevent falling when the case casting is lifted off later. Pushrod housing rubber

connectors may be placed on individual valve lifters for the same purpose.

- d. Turn the work stand bed to place the crankcase cover upward. Loosen and remove the oil screen from its housing in the cover.
- e. Loosen the bronze acorn cap of the oil pressure relief valve at the right rear side of the -8 rear cover or at the right side of the -12, -14, -16 or 0-200 crankcase cover. Hold against spring force as the cap is unscrewed and comes free. Lift out the spring and the plunger.
- f. If the engine is a -8 model loosen the tachometer drive housing by turning the hex shoulder to the right. Do not remove it.

CAUTION

The tachometer drive housing in the -8 cover assembly is screwed into the cover boss with a left hand thread. Attempts to loosen by turning to the left will tighten thread and do serious damage.

- g. At this stage, the -8 model crankcase cover will be attached to the ten crankcase studs. Remove the retaining nuts, and lift off the cover and attached parts.
- h. At the same stage of disassembly, the crankcase cover of a -12, -14, ~16 or an 0-200 model will be attached by two crankcase studs through the oil screen housing flange and five shorter studs. Remove the oil screen housing retaining nuts and the housing; then remove the other five cover retaining nuts, and lift the partial assembly from the crankcase.
- i. Insert a screwdriver through one of the camshaft gear holes to prevent turning, and loosen the four camshaft gear retaining screws. Run the screws out, and lift the gear from the camshaft pilot.
- j. Loosen and remove the four crankshaft gear retaining screws, and lift off the gear.

- k. Unscrew and remove the breather elbow ahead of No.3 cylinder.
- l. Turn the work stand bed to place the crankshaft in a horizontal position and the crankcase, 1, 3, side upward.
- m. If the engine is an O-200 model, remove three 1/4 in. nuts, lockwashers and plain washers and one 5/16 in. nut, lockwasher and plain washer; then withdraw the vacuum pump adapter assembly.
- n. Loosen the 14 nuts on the crankcase parting flange screws, and remove the eleven 1/4 inch screws and three dowel screws. The engine lifting eye will be removed with two of the nuts. If necessary, tap the close-fitting dowel screws from their flange holes.
- o. Remove two nuts from 7/16 inch crankcase through studs ahead of No.4 cylinder and the nut from the 3/8 inch through stud above the lower right engine mount arm. Detach the 1, 3 side mounting arms. If engine is equipped with through bolts at the center bearing boss locations, drive them out with a non-marring hammer. Catch the bolts as they come free of the 2, 4 side crankcase half.
- p. Lift the 1, 3 side case casting straight upward clear of the through studs, and lay it on a wood surface with parting flange up.
- q. Lift out the crankshaft and connecting rod assembly, collecting the bronze thrust washers at the front main journal as they come out. (Old type thrust washers are retained by case dowels and must be removed after the case castings and shaft are separated.)
- r. Remove the camshaft from its bearings, and remove all valve lifter bodies from their guides. Store bodies with mating units.
- s. Lift each main bearing insert from its seat, and discard.
- t. If the engine is a -12, -14, -16 or 0-200 model, remove the starter pinion pivot from the 2, 4 side casting; then remove the casting from the work stand, and store it on a wood surface.

NOTE . . . Current production crankcases have a gallery drilled to lubricate the starter clutch adapter. Old style cases can be adapted per instructions in para. 14-13A.

11-19. CONNECTING RODS

For greatest ease of disassembly, it is suggested that the crankshaft be held in a fixture similar to that illustrated in Figure 23, if it is a tapered shaft, or in a suitable flange holding fixture if it is a flange type shaft. Remove all cotter pins from connecting rod bolts, and loosen all slotted nuts. Unscrew the nuts from bolts of each rod, in turn, and take rod and cap from the crankpin. Discard bearing inserts, and reassemble rods and caps loosely to avoid mixing.

11-20. CRANKCASE

If no fuel pump or oil cooler was installed remove the mount pad covers and gaskets. Unscrew and remove the oil gallery front plug from each casting. Do not remove dowel pins from the case rear flanges. Remove mount bushings.

11-21. CRANKCASE COVER

If the engine is a -12, -14, -16 or 0-200 model loosen and remove the three elastic stop nuts or slotted nuts which attach the tachometer drive housing, and pull the housing straight to the rear and free of the shaft. If the cover is for a -8 model unscrew and remove the tachometer drive housing and oil seal assembly. Discard gaskets. Remove lockwire from the oil pump cover attaching parts, the attaching parts and the oil pump cover at the front of the crankcase cover. Lift out the oil pump impellers.

11-22. CYLINDERS

With the following procedure a suitable lever type valve spring compressor must be used to bear on the rocker shaft as a fulcrum. If a press type fixture is used the process will be slightly different.

- a. Slide out the rocker shaft, and remove the two rocker arms. Mark the arms for position or store them in a marked container.

- b. If pushrods were not previously removed, take them from their housings, and store them in marked containers to identify their cylinder numbers and positions and their crankcase ends.
- c. Replace the rocker shaft, and set the cylinder on a suitable fixture which will hold down the base flange, with the cylinder upright, and which will prevent the valves dropping inward.
- d. With the lever compressor, depress either valve spring retainer enough to free the split stem lock, and lift out the two locks with long nose pliers, being careful to avoid binding in the stem groove and nicking the valve stem. (See Figure 19.)
- e. Release the spring seat, and lift off the valve springs, spring seat and inner retainer.
- f. Repeat steps d and e to remove the parts from the other valve.
- g. Lift the cylinder by the two valve stems; remove it from the fixture, and lay it on its side on a bench.
- h. Grasp one valve head at a time, and withdraw the valve through its guide. Valves need not be marked for position, since they will be refaced. Remove the cylinder base packing ring from the barrel skirt.

11-23. HYDRAULIC VALVE LIFTERS

A Rack should be constructed to hold the disassembled lifter parts, i.e., lifter bodies, hydraulic units and sockets so that their original assembly relation will be obvious. The groups of rack holes or compartments should be labeled "No. 1 IN.", "No.1 EX.", etc. The parts named will already be separated and should be in the proper rack holes at this stage. The only disassembly remaining is that of removing the plungers from hydraulic units. This operation should be performed only at the time of cleaning of individual parts and testing of same. The plungers should be replaced in cylinders immediately after cleaning. Ordinarily, the plunger may be removed from the cylinder by turning to wind up the spring and pulling it out. If the plunger appears to be

stuck, refer to paragraph 10-43 for removal procedure. (Also see Figure 20.) If these measures are not effective discard the unit.

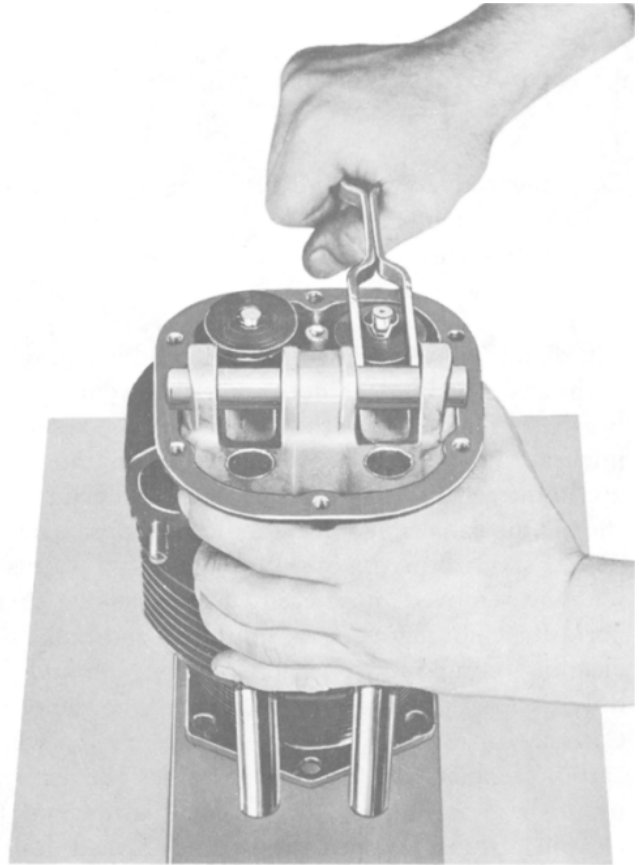

Figure 19. Compressing Valve Spring to Remove Locks

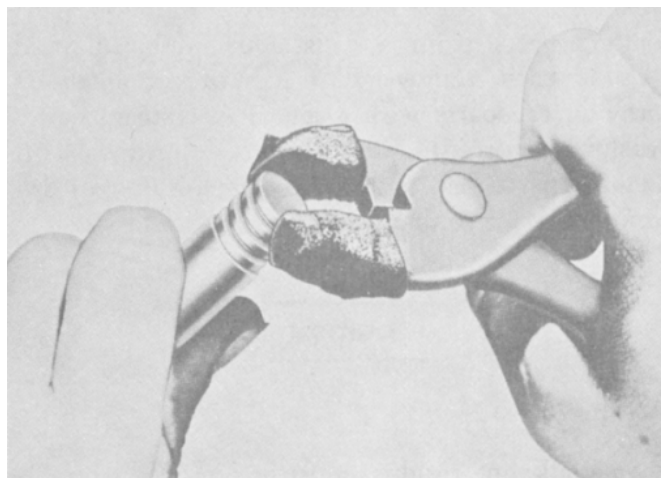

Figure 20. Removing Plunger From Hydraulic Unit With Taped Pliers

SECTION XII

CLEANING PARTS

12-1. MATERIALS AND PROCESSES

12-2.

Equipment, materials and processes in general use in aircraft engine overhaul shops are satisfactory for cleaning engine parts.

12-3.

Aluminum alloy parts can be degreased by spraying with any fortified mineral spirit solvent or by brush application of the same liquid. Fortified mineral spirits are more effective when the parts are immersed in them and allowed to remain for a short time to permit solvent action to loosen caked deposits. Carbon deposits and gum (oil varnish) may be removed most easily by immersing these parts in a hot bath of an inhibited, mild alkaline cleaning compound. Immersion time should be only as long as necessary to remove the deposits. Carbon solvent should be employed only when carbon deposits are too hard and thick for removal by other solvents. Give special attention to cleaning studs, tapped holes and drilled holes. Caution must be exercised in cleaning of all aluminum alloy engine parts. Do not use any strong alkaline solutions to clean aluminum alloy castings or wrought aluminum alloy parts, because strong solutions will attack and destruct a bare machined surface. Immediately after removing soaking parts from a caustic or inhibited, mild alkaline bath, remove all traces of the alkali by spraying the parts with a jet of wet steam or by brushing vigorously with a mineral spirit solvent. Cleaned parts may be dried by use of a jet of dry compressed air to remove all solvent liquids.

| |
|----------------|
| CAUTION |
|----------------|

All alkaline residues must be removed from crevices, recesses and holes, as well as from other surfaces, to prevent the formation of a foaming emulsion in the engine lubricating oil after reassembly.

12-4.

No polishing compound or abrasive paste or powder should be needed or employed for cleaning engine parts. Scraping, abrasion with wire brushes, sand paper or abrasive cloth and buffing wheels are dangerous methods to use on soft metals such as aluminum. Scratches resulting from such methods allow a concentration of stress at the scratch and may cause fatigue failure.

12-5.

Various blasting techniques can be employed to remove hard carbon deposits if suitable equipment is available. The most suitable types of grit for dry blasting are plastic pellets and processed natural materials, such as wheat grains and crushed fruit pits or shells. Air pressure should be the lowest that will produce the desired cleaning action. Small holes and finished surfaces which do not require cleaning should be protected from the blast by seals and covers, particularly if the grit is sharp. Sand, shot and metal grit are too abrasive and too heavy for use on soft metals such as aluminum. After any blasting process, blow off all dust with dry compressed air and make sure that no grit has lodged in crevices, recesses and holes.

12-6. SPECIFIC PARTS

12-7. CYLINDERS

Precautions applicable to both aluminum and steel must be exercised in cleaning and storing these assemblies. Remove oil and loose material with a mild alkaline cleaner by spraying or brushing. If stubborn deposits of carbon remain on cylinder heads, the areas affected may be vapor blasted. All machined surfaces must be protected from abrasive action during the blasting operation.

12-8. PISTONS

Do not use wire brushes or scrapers of any kind. Soft and moderately hard carbon deposits may yield to solvent action. If deposits remain, blast the heads with soft grit or by the vapor grit method, first having installed tight fitting skirt protectors. Ring

grooves may be cleaned by pulling through them lengths of binder twine or very narrow strips of crocus cloth. Do not use automotive ring groove scrapers, since the corner radii at the bottoms of the groove must not be altered, nor any metal removed from the sides. Discoloration and light scoring need not be removed from piston skirts. The use of abrasive cloth on the skirts is not recommended, because the diameters and cam-ground contour must not be altered. Heavily scored or burned pistons should be discarded.

12-9. VALVES

After degreasing valves, inspect them and discard any whose head is warped excessively, or which has insufficient stock to permit refacing within specified limits, or whose stem is burned, scored, eroded or nicked. Carbon deposits may be loosened by solvent action or they may be scraped off while the valve is rotated in a polishing head or lathe collet. Apply crocus cloth moistened in mineral spirit, and polish the stems with dry crocus cloth.

12-10. ROCKER SHAFTS

Degrease these parts by brushing on any mineral spirit solvent. Prior to magnetic inspection, polish the steel bearing surfaces with crocus cloth moistened with kerosene, then with dry crocus cloth.

12-11. PUSHRODS, VALVE ROCKERS AND OTHER SMALL STEEL PARTS

Degrease these parts with mineral spirit solvent, paying special attention to removal of sludge from all oil passages.

12-12. CAMSHAFT AND CRANKSHAFT

All parts may be degreased by brushing or spraying with mineral spirit solvent. Pay particular attention to threads, oil holes and recesses. Before magnetic inspection, the crank pins, main journals, oil seal race of the crankshaft and all journals, cam lobes and gear mount flange of the camshaft must be smoothed with crocus cloth, moistened in a mineral spirit. If possible, this should be accomplished while shaft is rotated in a high speed lathe (about 100 rpm). All gum (varnish) deposits must be removed to permit reliable magnetic indications.

12-13. CONNECTING RODS

If a mineral spirit solvent does not clean these parts thoroughly, they may be immersed in a chemical carbon solvent. They should be immersed only long enough to loosen and soften the deposits without adversely affecting the metal. The parts should be pre-soaked in mineral spirit fortified with organic solvents to soften the hardest deposits. After removal from the carbon solvent the parts should be rinsed or sprayed with mineral spirit. Do not use a wire brush or other coarse abrasives. Vapor blasting may be employed if bushings and bearing slots are protected from the abrasive. Discoloration need not be removed from piston pin bushings, and no abrasive cloth or paste should be used. All vapor blast grit or chemical must be removed.

12-14. CRANKCASE

The oil passages should be pressure-flushed with mineral spirit solvent and inspected with the aid of a flashlight. If the castings are immersed in an alkaline bath, it is strongly recommended that such treatment be followed by spraying with a jet of wet steam and this followed by flushing of the oil passages with solvent. After the castings dry, inspect them thoroughly for alkaline residues, and remove any traces of scum.

12-15. GEARS

Gears without bushings may be freed of hard deposits by immersion in a caustic stripping bath, when cold solvents are not effective. Bushings are discolored by such treatment, hence bushed gears should be cleaned by other methods such as spraying and/or brushing with a mineral spirit solvent and brushing with a brass wire brush.

12-16. SHEET METAL PARTS

Clean these parts with a mineral spirit spray or by brushing with the same liquid, or use a cold emulsion type cleaner and flush with water to rinse.

12-17.

Immediately after cleaning bare steel parts spray them with or dip them in clean engine oil or, for longer storage, in a corrosion-preventive oil mixture. Wrap ball bearings in waxed paper. Wrap or cover other clean parts to protect them from abrasive dust in the air.

SECTION XIII

INSPECTION

13-1. DEFINITIONS

Terms used in this section to describe various defects are defined as:

- a. Abrasion: Light scoring or scratching caused by direct contact and friction between two parts or by cleaning with abrasive materials.
- b. Burrs: Sharp, rough, upstanding edges.
- c. Corrosion: Rust (oxidation) or deterioration of metal, leaving a rough, uneven surface.
- d. Deformation: Any departure from original surface shape or finish, such as bends, twists, elongation, crushing, flattening, peening, indentation or gouging.
- e. Fretting: Rusty appearance (of steel) caused by vibration of or against a mating part.
- f. Elongation: Stretching, or increase in length.
- g. Galling: Pick-up of soft metal on a harder surface, due to excessive friction and heat.
- h. Pitting (or spalling): Small, deep cavities in a surface.
- i. Oxidation: Chemical combination of a metal with oxygen.
- j. Run-out: Eccentricity or wobble (full indicator deflection).
- k. Scoring: Deep scratches caused by friction or abrasive particles.

13-2. INSPECTION TOOLS

13-3. GAUGES

Micrometer calipers, both inside and outside types, are the only measuring instruments which can be used to determine wear by measurement of a variety of sizes with sufficient accuracy for reliable comparison with specified limits. Since inside micrometers are rather difficult to use with small parts, telescoping gauges are often fit to the bores and locked so that they can be measured, as

substitutes, with outside micrometers. All micrometer calipers must be handled carefully and kept clean and free from corrosion to maintain accuracy and free operation. They should be checked for "zero error" and readjusted when necessary, due to wear, in order that readings will be of value. Nearly all micrometer calipers have means of taking up wear in the thread to overcome looseness after long service. Such adjustments must be made carefully when necessary. Various types of dial gauges are sold for measurement of larger bores. These provide a rapid method of measurement when many pieces are handled. Cylinder bore gauges of this type are particularly to be recommended, since they offer an easy and time-saving means of reaching the remote end of the barrel. Dial gauges of this type must be set to an accurate ring to give direct measurements within a narrow range. Other dial indicators of various patterns are available for measurement of "run-out", or eccentricity, between normally concentric bores and journals or between journals which are nominally in line. Such gauges may also be used to measure other type of "run-out", or wobble, between shafts, or bores, and nominally perpendicular flanges or to indicate variations in height, when used with height gauge holders, or fixed supports, and surface plates. Several types of dial indicators should be available in every shop for inspection work. Fixed, adjustable, gauges, such as snap gauges and plug gauges materially speed inspection, however, they are useful for single dimensions only, so that a large number would be required to make all necessary measurements in the engine. The expense of making these special tools usually makes their cost prohibitive, unless a large volume of work is handled. Thickness gauges are required for measurement of backlashes and end clearances. These are available in several ranges of thickness and blade pattern. Spark plug wire gauges are necessary for measurement of electrode gaps in some types of spark plugs. These are supplied by spark plug manufacturers and tool dealers.

13-4. FIXTURES

A surface plate is practically a necessity, unless special fixtures are available for checking crankshaft alignment and connecting rod bearing alignment. With a true surface plate, a set of accurate, matched Vee blocks, a surface gauge (or a fixed holder for a dial indicator) and two accurately ground parallel blocks of the same height, it is possible to measure alignment of crankshafts, camshafts and connecting rod bearings and bushings. In order to measure "run-out", or wobble, of gears, they may be assembled to the shafts on which they operate and checked in Vee blocks. This is unnecessary, except when the wear pattern indicates an irregularity in running. Piston pins may be mounted between bench centers of lathe centers or in Vee blocks to measure out-of-roundness and bending.

13-5. INSPECTION METHODS

13-6. VISUAL INSPECTION

A preliminary visual inspection of all parts will indicate whether any are deformed, corroded, scored, galled, pitted or otherwise damaged beyond repair. A more careful visual inspection should be performed on each part to determine the need for minor repair, such as stoning to remove nicks, chasing or stoning of slightly deformed threads or lapping of parting flanges. Visual inspection to detect cracks is often difficult, and a magnifying glass is a very useful tool for this work, however, if cracks are suspected in any aluminum casting and if they cannot be verified by visual inspection, that part of the area should be etched. Visual inspection should also include a detailed observation of all areas, holes, pockets and threads to ascertain that all foreign material, cleaning compound and abrasives have been removed.

13-7. ETCHING

Before etching any area to be inspected for cracks, all enamel, carbon and oil must be removed. The surface should be clean and dry. The following procedure and precautions apply.

- a. Paint the area with a solution made by dissolving caustic soda in water (at room temperature) in the proportions of 2 lbs. of caustic soda per gallon of water. Expose the aluminum surface to the cleaning action of the solution for no more than 60 seconds.
- b. Immediately rinse the part in running water; then neutralize the action with a solution of 1 part nitric

acid in 4 parts water. Allow the diluted acid to act only long enough to remove the black deposit left by the alkali.

- c. Rinse the part thoroughly and dry with compressed air. The etching process will leave the surface perfectly clean, but the black deposit will remain in cracks and deep scratches. These may be seen more clearly with a magnifying glass and, thus, distinguished.

13-8. DIMENSIONAL INSPECTION

Diametrical and end clearances, interference (tight) fits, out-of-roundness and "run-out" of all important part dimensions are listed in Section XVIII. In most instances, each of two mating parts must be measured and their dimensions compared to determine whether the fit is correct. This applies to tight fits, as well as to running fits. When a tight fit requires that the female part be heated before insertion of the male part, both parts must be measured at the same room temperature before heating 'of the former. Since new bearing inserts will be installed in the crankcase and all connecting rods, it is unnecessary to measure the new bearing diameter. For this reason and others, certain parts should be inspected for individual dimensions against individual limits or the serviceable limit of fit. Some dimensions for this purpose are listed in Section XVIII. Other necessary dimensions are:

| Feature | New Dimensions (Inches) |
|-------------------------------------------------------------|----------------------------|
| Intake valve guide bore | 0.3432-0.3442 |
| Exhaust valve guide bore | 0.437-0.438 |
| Cylinder barrel bore | 4.062-4.064 |
| C75, C85 Piston (Std.) diameter | |
| *At top of skirt | 4.051-4.053 |
| *At bottom of skirt | 4.054-4.055 |
| C90, O-200 Piston (Std.) diameter | |
| *At top of skirt | 4.049-4.050 |
| *At bottom of skirt (above 4 th groove) | 4.052-4.053 |
| Piston pin bore diameter..... | 0.9217-0.9221 |
| Piston pin diameter..... | 0.9214-0.9216 |
| Rocker Arm bushing bore | 0.6097-0.6107 |
| Rocker shaft diameter..... | 0.6082-0.6087 |
| Rocker shaft boss bore | 0.6089-0.6099 |
| *Measured at right angles to pin bore. | |

NOTE

Reground barrels (.015 inch oversize must be within limits No. 44, Section XVIII, and taper may not exceed .002 inch, with largest diameter, if any, at bottom. Bore must be less than .001 inch out-of-round and less than .001 inch out-of-square with flange, full indicator reading, in length of barrel.

13-9. MAGNAFLUX INSPECTION

Parts listed in Table XIX should be inspected at each overhaul by the Magnaflux process or an equivalent method of crack detection. Table XIX provides data for proper inspection by the Magnaflux method. When this process is used, the following precautions must be observed to assure reliable results and safe condition of inspected parts.

- a. Parts must be free of carbon and oil.
- b. Crankshafts and piston pins must be polished before inspection.
- c. All parts should be inspected for forging laps, seams and grinding cracks which may have opened in service.
- d. The suspension liquid should be maintained at a strength of 1-1/2 oz. of red Magnaflux paste No.9 per gallon of kerosene.
- e. The suspension liquid must be vigorously and continuously agitated to keep magnetic particles circulating.

CAUTION

Before magnetization, all small openings and oil holes leading to obscure cavities must be plugged with either a hard grease or similar non-abrasive material, which is readily soluble in lubricating oil, or wood or fibre plugs to prevent accumulation of magnetic particles where they cannot be removed completely by washing and air blasting.

- f. All parts must be completely demagnetized after inspection and between successive magnetizations. Demagnetization is performed by inserting the part in an alternating current demagnetizer, from which it is withdrawn slowly. Irregular shaped parts must not be withdrawn at a rate of more than 12 feet per minute.
- g. The magnetic substance must be removed completely from all parts after inspection. All plugs must be removed.

13-10.

Both the wet continuous method and the wet residual method are used. In the former process, the magnetic solution is poured over the part while it is mounted between poles of the magnetizer, and application of the fluid is stopped as the magnetizing current is started. In the wet residual process, the part is immersed in the magnetic suspension fluid after it has been magnetized. TABLE XIX shows the method recommended for inspection of each kind of part.

NOTE

If the crankshaft is suspected of any defect not firmly established by inspection after circular magnetization, it should be demagnetized and magnetized longitudinally for further inspection.

13-11.

Two methods are used to support parts between poles of the magnetizer for circular magnetization. They are:

- a. Pads of copper braid or soft lead plate are installed on the pole pieces, and the part is clamped between them to assure good contact and to prevent burning.
- b. The parts are strung on a copper rod, which is held between poles of the magnetizer.

13-12.

Following demagnetization the parts must be thoroughly cleaned by spray and air blast. Plugs should be removed before cleaning to admit fluid and air to all holes and cavities. When dry, the parts should be flushed in a corrosion-preventive oil.

TABLE XIX
MAGNETIC PARTICLE INSPECTION
FLOURESCENT METHOD PREFERRED,
WET CONTINUOUS PROCEDURE REQUIRED

| Part | *Method of Magnetization | AC or DC Amperes | Critical Areas | Possible Defects |
|----------------------------|--------------------------------------------------|-------------------------|-----------------------------------------------------------|--------------------------------------------------------------|
| Crankshaft | Circular and Longitudinal | 2000 | Journals, fillets, oil Holes, thrust flanges, Prop flange | Fatigue cracks, Heat cracks, Flange cracks, From prop strike |
| Connecting Rod | Circular and Longitudinal | 1500 | All areas. | Fatigue cracks. |
| Camshaft | Circular and Longitudinal | 1500 | Lobes, journals Drilled hole edges | Heat cracks, Fatigue cracks |
| Piston Pin | Circular and Longitudinal | 1000 | Shear planes, ends, Center. | Fatigue cracks. |
| Rocker Arms | On Conductor Bar And Single Between Heads | 1000 | Pad, socket under side Side arms and boss. | Fatigue cracks |
| Gears to 6 Inch Diameter | Circular or On Center Conductor | 1000 to 1500 | Teeth, splines, Keyways. | Fatigue cracks |
| Gears over 6 Inch Diameter | Shaft Circular Teeth Between Heads Two Times 90° | 1000 to 1500 | Teeth, splines | Fatigue cracks |
| Shafts | Circular and Longitudinal | 1000 to 1500 | Splines, keways, Change of section. | Fatigue cracks, Heat cracks. |
| Thru Bolts Rod Bolts | Circular and Longitudinal | 500 | Threads under head | Fatigue cracks |

13-13. FLUORESCENT PARTICLE INSPECTION

This process, commonly known under the trade name of "Zyglo", is recommended for inspecting aluminum alloy and magnesium alloy parts for invisible cracks. The standard operating technique for the process is applicable.

13-14. INSPECTION OF CRITICAL PARTS

13-15. CRANKCASE

Inspect the following features by applicable methods.

- a. Examine carefully for fatigue cracks, especially around cylinder pads.

- c. Examine bearing seats for cracks, scratches and nicks.
 - d. Inspect parting flange surfaces for nicks and warp.
 - e. Examine camshaft bearings for scores, cracks and excessive wear.
 - f. Inspect valve lifter guides for wear and scoring.
 - g. Examine oil galleries and feed holes for cleanliness.
 - h. Check all studs for damaged threads, tight fit, height and bends.
 - i. Inspect all surfaces for removal of cleaning compounds.
- f. Nicked, pulled, peened or stripped threads in rear flange tapped holes or at front end (exterior) of a tapered shaft.
 - g. Fretting of the puller hub taper.
 - h. Run-out at center journals and front end (and propeller flange).

13-16. CRANKSHAFT

Inspect for the following kinds of damage and wear.

- a. Cracks (use Magnaflux equipment or the equivalent).
- b. Galling, scoring, burning and wear on main journals and crank pins and their fillets.

NOTE

Crankshafts which have been reground to .010 inch undersize should be inspected for fillet radii. Radii of main journal fillets must be 5/32-11/64 inch, and radii of crank pin fillets must be 11/64-3/16 inch. Crankshafts which were originally nitrided must be re-nitrided after grinding. (Refer to paragraph 3-8.)

- c. Make sure that oil tubes are tight and free of obstructions.
- d. The Hubbard plug at the front end of flange type shafts must be removed before Magnaflux inspection.
- e. The screw plug in the front end of a tapered crankshaft must be removed before Magnaflux inspection. Observe thread condition of plug and tapped hole.

13-17. CONNECTING RODS

Inspect alignment in plane (convergence) and twist of the crank pin bearing seat (without inserts) and the piston pin bushing. If the bushing was replaced its bore should be compared with limits in The Table of Limits, Section XVIII; if not, the bore should be compared with the piston pin diameter. Look for peening on all surfaces and bends in the beam. Check cap bolts for elongation. (Note position of cotter pin hole in nuts slots.) Observe condition of threads.

13-18. PISTON PINS

The pins should be inspected visually before polishing and dimensionally before and after polishing. Pressed in end plugs should be inspected visually for damage after Magnaflux inspection. Loose fitting end plugs should be checked for snug fit in pins and wear on ends. Measure pin diameter, out-of-round, bending.

13-19. PISTONS

Inspect for removal of carbon and oil varnish. See that fillets of roots of ring grooves were not deformed or reduced. Look for scores extending the length of the skirt, burning, and cracks. Discard any piston which is cracked, heavily scored, deformed, burned, corroded by salt water or worn beyond dimensional limits (Refer to paragraph 13-8.)

13-20. PUSHRODS

Roll all rods on a surface plate, and check for bending. Very slight bending may be corrected by tapping with a non-marring hammer or lead mallet. Inspect ball ends for excessive wear. See that the oil passages are clear.

13-21. ROCKER ARMS

Excessively worn bushings should be / removed before Magnaflux inspection and replaced afterward. Inspect used and replaced bushing bores. See that oil holes are clear. Look for worn sockets

and badly worn, rough or chipped stem rockers. See that oil hole plugs are tightly installed.

13-22. VALVES

Inspect for cleanliness, warp of heads, limit of face regrind, limit of stem tip regrind, scored stems, stem diameter and burning. Discard all excessively ground, worn, scored or warped valves. After regrinding, lapping and installation all valves should be checked for full seating.

13-23. VALVE SPRINGS

Look for cracked or broken ends, corrosion and correct color coding. Use a spring test machine to determine whether any valve spring is weak.

13-24. CAMSHAFTS

Inspect journals for scoring, deformation and excessive wear. Inspect cam lobes for profile wear, scoring, and pitting, particularly along the toe line. If any valve lifter body in the group did not turn during the previous operating period, its cam lobe should be measured for a taper on the toe. A slight taper is ground on the toe line of all lobes to turn the lifters. Its value is expressed as an angle and its linear dimension amounts to a very few thousandths of an inch, but it is important that some taper be present. Inspect fuel pump eccentrics for wear and scoring. Check thread condition of tapped holes at the rear flange of all camshafts and at the front end of -16 and O-200 camshafts. Inspect shims of bevel gears for the latter type to make sure that they are perfectly flat.

13-25. CYLINDERS

Examine steel barrel fins for bending and aluminum head fins for cracks. All steel fins should be straight and even to permit air flow. Not over 10% of head fin area may be removed by cracking or by cutting out to stop cracks, without reducing cooling efficiency dangerously. Small cracks starting at the edges of head fins should be marked for repair by drilling reliefs. If cracks extend to the fin roots the head wall is probably cracked and should be discarded. Inspect all finished surfaces for nicks, peening, cracks, residual gasket material and deep scratches. These defects may permit oil leakage. Inspect valve port studs for burrs, stripping, bending, elongation and backing out. Examine spark plug inserts for thread condition and tight

installation. Inspect cylinder base flanges for cracks, bending, nicks, corrosion and smoothness of nut seats. Inspect rocker shaft support bosses for cracks, worn bores and side wear. If bores are worn excessively the bosses may be repaired by installation of repair bushings, and they should be marked for such attention. See paragraph 14-8g. Inspect valve guides for proper clearance with valve stems, and measure replaced guides for diameter and for concentricity within .002 inch with valve seat insert throats. Make sure that pushrod housings are tightly installed in the rocker box holes. Mark cylinders which will require replacement of valve seat inserts which have been ground to a diameter equal to the O.D. of the valve head. Measure the cylinder bore, and classify the cylinder, according to the reconditioning required, as:

- a. Grind to remove ring step and hone bore.
- b. Grind to .015 inch oversize and hone.
- c. Rebarrel.

After regrinding and honing, the bore should be rechecked for diameter, taper, squareness with flange, roundness at all sections and surface roughness, (Refer to limits, No. 43-44, Section XVIII.)

13-26. HYDRAULIC VALVE LIFTERS

Inspection of lifter parts should be conducted at the time of cleaning. A rough test of hydraulic unit operation is described in paragraph 10-43. Accurate determination of leakdown rate is also discussed in the same paragraph, and such methods are recommended, however, they require special inspection fixtures. Visual inspection should include examination of follower faces for scoring, grooving, spalling and corrosion. The shank of each lifter body should be measured to determine clearance in its crankcase guide. The bearing surface should also be examined for scoring, galling, cracks and clear oil holes. Inspect each socket for clear oil passages and for excessive wear in the cup. All parts must be thoroughly clean. Following inspection they should be coated with a corrosion-preventive oil.

13-27. GEARS

The crankshaft and camshaft gears should be inspected by Magnaflux methods for cracks. In addition, all gears should be inspected visually for

deformation and burring of the teeth, excessive tooth profile wear or scoring. The starter driven gear wheel of the crankshaft gear in -12, -14, -16

and O-200 models must be discarded if any chipping or serious gouging of the entering edges is found.

SECTION XIV

REPAIR AND REPLACEMENT

14-1. GENERAL REPAIR

14-2. CASTINGS

Remove the raised edges of nicks and burrs on machined surfaces with a hard Arkansas stone. Unobstructed flat surfaces, such as cover plates etc. may be returned to true flatness if a lapping plate is available. Use a fine grade lapping compound and move the part in a figure 8 motion evenly.

14-3. STUD REPLACEMENT









Remove damaged whole studs with a standard stud remover or a small pipe wrench. Turn slowly to avoid overheating. Remove broken studs which cannot be gripped by drilling on center to the correct diameter for and unscrewing them with a splined stud extractor. (Splined extractors and drills are usually sold in sets.) Examine the coarse thread end of the damaged stud to determine its size. Standard studs have no marking. For oversize stud identification refer to Table XX. Clean the tapped

hole with solvent and blow dry with compressed air; then examine the thread. If it is not damaged install the next larger oversize stud. If the old stud was maximum oversize, or if the thread is damaged, the hole may be tapped and a helical coil insert installed for a standard size stud. Coat the new studs coarse thread with Alcoa Thread Lube if the hole is blind or with National oil Seal Compound if it is a through hole that is subject to oil spray. It is advisable to drive the new stud with a tee handle stud driver. Turn it slowly, and compare the estimated torque with values listed in Section XVIII. Drive the stud in until it projects a distance equal to others in the same group.

14-4. HELICAL COIL INSERT INSTALLATION

Helical coil thread inserts are factory installed at various locations. These inserts may be replaced, if damaged, with the aid of a helical coil remover and replacer. (See Figure 21.)

TABLE XX STUD IDENTIFICATION CHART

| Typical Part No. | Oversize on Pitch Dia of Coarse Thread (inches) | Optional Identification Marks on Coarse Thread End | | Identification Color Code |
|------------------|-------------------------------------------------|-------------------------------------------------------------------------------------|--------------------------------------------------------------------------------------|---------------------------|
| | | Stamped | Machined | |
| XXXXXX | Standard | None |  | None |
| XXXXXXP003 | .003 |  |  | Red |
| XXXXXXP006 | .006 |  |  | Blue |
| XXXXXXP009 | .009 |  |  | Green |
| XXXXXXP007 | .007 |  | | Blue |
| XXXXXXP012 | .012 |  | | Green |

14-5.

Helical coil inserts are manufactured from wire with a "diamond" shaped cross section forming both a male and female thread. Drilling and tapping depths for inserts, being installed in blind holes, should be equal to twice the nominal diameter of the insert. The helical coil drills and taps must be absolutely perpendicular to the machined surface of the casting. Drilling should be accomplished in a drill press after the casting is firmly supported, clamped and alignment checked. For drilling and tapping aluminum alloy castings, use a lubricant made of one part lard oil and two parts kerosene thoroughly mixed to prevent overheating the metal and damage to the threads.

14-6.

To remove a damaged helical coil use the proper size extracting tool specified for the nominal thread size. Tap the tool into the insert so the sharp edges get a good "bite". Turn the tool to the left and back the insert out. To install a new insert, blowout all chips and liquid, slide the insert over the slotted end of the mandrel, and engage the driving tang in the mandrel slot. Wind the insert into the tapped hole slowly (See Figure 21). The outer end of the insert should lie within the first full thread of the hole. Break off the driving tang with long nose pliers.

14-7. REPAIR AND REPLACEMENT OF SPECIFIC PARTS

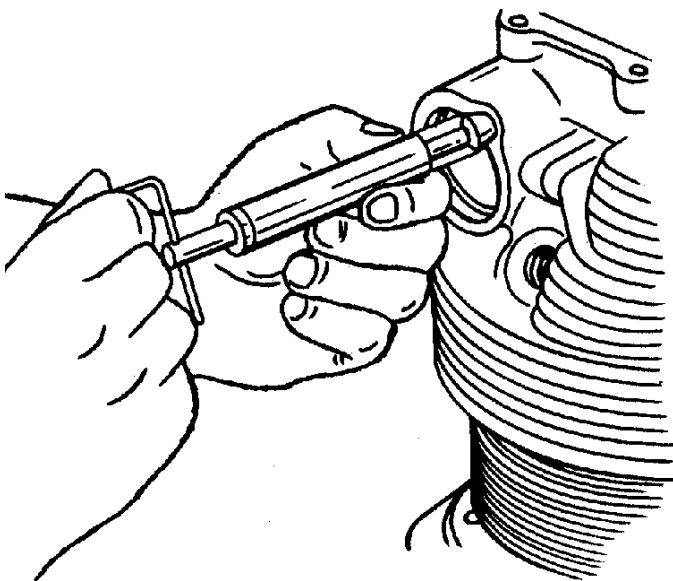

Figure 21. Installing Helical Coil Inserts

14-8. CYLINDER AND HEAD ASSEMBLY
Before application of enamel, any of the following repairs found necessary by inspection should be completed and reinspected.

- a. If the cylinder bore is not more than .005 inch oversize the ring step at the head end of the barrel may be removed by grinding and the bore glaze may be roughened by honing to restore the original finish. The proper surface roughness of refinished cylinder walls is specified in limit No. 44, Section XVIII. A close approximation of the correct bore surface may be maintained by visual inspection of refinished cylinder walls with a magnifying glass and by comparison with the appearance of new cylinder bores. The hone marks in factory finished cylinders have a definite cross pattern, with an appreciable flat between grooves. This finish allows enough depression to hold oil during the break-in period without sacrificing flat bearing area for the ring faces. The crossed pattern of the grooves allows each ring to slide over them with no tendency to dig in. Honing scratches which have a circular pattern invite the sharp lower edge of each tapered ring face to attempt to follow their contour, causing rapid removal of metal from the high points and ridges of both cylinder wall and ring face. The crossed pattern is achieved by honing in a figure 8 motion with rapid reciprocation of the honing head in proportion to its rotation speed. If a spring-loaded hone is employed it will not be possible to reduce the out-of-roundness of the bore appreciably nor will the taper be reduced by the amount of honing required to roughen the surface. If the values of these irregularities exceed those specified in limit No. 43, Section XVIII, the cylinder should be reground to oversize or rebarreled, if already oversize.
- b. If cylinder bores are tapered or out-of-round beyond limits they may be reground and honed to .015 inch oversize and installed with .015 inch oversize pistons and rings. The refinished bores must be:
 1. Not over .001 inch eccentric to ground skirt pilot.

2. Not over .001 inch out-of-round at any point.
 3. Not over .001 inch out-of-square with ground surface of flange, as measured at top of bore.
 4. Not over .001 inch tapered in full length of bore, with large diameter, if any, at bottom.
 5. Within limits of diameter (Refer to limit No. 43, Section XVIII.)
- c. If valve guides are loose, worn beyond limits or scored they must be replaced with the next oversize. The cylinder should be supported in the inverted position and the old guides pressed out with an arbor press and a driver piloted in the guide bore. Bore or broach the cylinder head bore for the specified tight fit with the replacement guide. (Refer to the Parts Catalog for available oversizes.) The cylinder head bore must be square with the cylinder axis and concentric with the valve seat throat. Concentricity must be maintained within .002 inch, so that the same limit can be held in the replacement guide. With the cylinder supported upright on a suitable fixture and seated on its mount flange, dip the insert end of the oversize guide in engine oil, and insert the other end in a close fitting socket driver which will bear on the guide flange. Start the guide into the head bore square, and press it to fully seated position in the cylinder head with the driver and an arbor press. Driving with a heavy mallet may be used as a substitute when an arbor press is not available, however, it entails some risk of peeling metal from the cylinder head, with a resulting loose fit and an out-of-square hole. It is not necessary to heat the cylinder for this replacement. Ream or broach the new guide to size.
- d. If the flanged and pinned type spark plug inserts are loose, stripped or rough on the gasket surface they should be removed, after drilling out the locking pin, with a tool which will dig into the 18mm thread in somewhat the same manner as a screw type stud extractor. When drilling out the locking pin, exercise care to avoid drilling into the combustion chamber. Use a No. 31 drill. Center punch the pin to locate the

drill point. Make sure that the lips of the drill are of equal length and angle to avoid enlarging the hole. Drill to a depth of only 7/16 inch from the bushing surface. Mark the cylinder head to locate the old pin hole. Inspect the cylinder head hole for thread condition, and clean it with solvent. Obtain the next oversize insert, and clean it thoroughly. The cylinder assembly must be heated to not more than 575° F. before installation of the new insert. If valve seats are to be replaced they should be removed and the cylinder head prepared for replacements so that one heat will serve both purposes. Drive the new spark plug insert into the heated head with a tool which will fit the spark plug hole thread and shoulder on the insert face. Be careful to start the insert thread square and to seat it firmly. Remove the driver after the head has shrunk enough to hold the insert tight. When the cylinder has cooled, drill a new pin hole with its center 3/16 inch from the center of the old hole and at a radius of 1/2 inch from the bushing center. Drill to a depth of 7/16 inch with a No. 31 drill. Drive in a new locking pin. Face the new insert square with the 18mm thread. Retap the 18mm hole to eliminate any out-of-roundness. Use a standard 18mm tap with 15mm pitch. If the cylinder incorporates a helical coil spark plug insert refer to paragraph 14-5 and 14-6 for removal and installing instructions.

- e. If either or both valve seats have been reground until the slight overhang of the valve head has been eliminated and can no longer be restored by cutting back with a 25° stone, or if the exhaust valve seat is burned or pitted, or if either insert is loose, the defective inserts must be replaced. In practically all instances it will be necessary to heat the cylinder and head assembly in an oven to 575° F. or to heat the cylinder head to that temperature by other means in order to remove the inserts. A tap or suitable alternate type of insert extractor must be used. Two extractors will be required, since the diameters of intake and exhaust valve seats differ. This operation always involves some chance of failure, especially in removing the steel exhaust valve seat, which is difficult to grip. Better results can be obtained if the tools

have a provision for feeding cold water to the insert throat surfaces. A squirt of cold water will shrink the insert and make its removal much easier. provided that the water does not come in contact with the aluminum head and shrink it too. For this reason, the cylinder can best be handled in an upright holder with the open end downward. If the tool has a pilot to enter the valve guide, the water passage can be drilled through the pilot stem and side holes drilled from the central inlet to the tap surface, so as to deliver the water squirt close to the insert. Unless the water can drain downward without touching the cylinder head, very little should be used. The hand which holds the extractor in an upright cylinder should be protected by an asbestos glove. After removal of seat inserts, examine the cylinder head counterbores and clean them with a cloth saturated in solvent. Dimensional inspection of counterbores which are not roughened will determine whether a standard or oversize insert must be installed. If the counterbore has any roughness or scoring whatever it should be bored to the correct tight fit with the smallest oversize insert for which it can be cleaned up. The oversize recess must be concentric with the valve guide within .002 inch. Heat the cylinder to 575° F. throughout, and install the new insert with a tool which will grip it lightly and will be piloted in the valve guide. A ball or lever detent on the insert holding shoulder is sufficient. When the tool is piloted in the valve guide, a quick thrust must be

used to seat the insert before it has time to heat. It is best to have the cylinder inverted during this operation. After a few seconds a firm blow with the installing tool will seat the insert.

- f. Worn valve seats must be reground at each overhaul to make a true seating ring for the reground valves. Current production engines have a 30° intake valve and seat. All cylinders being repaired should be converted to the new configuration. Replacement seat inserts must be ground to correct size. Necessary dimensions for valve face and seat grinding are:

| | |
|-----------------------------------------------------------------------------------|-------------------|
| Valve seat angle (to guide axis) exhaust: | 45° |
| Valve seat angle (to guide axis) intake: | 59° 30' - 60° 00' |
| Valve face angle (to valve axis) exhaust: | 45° 45'-46° 15' |
| Valve face angle (to valve axis) intake: | 60° 45'-61° 15' |
| Intake valve seat outside diameter: (inches) | 1.662-1.682 |
| Exhaust valve seat outside diameter: (inches) | 1.537-1.557 |
| Valve seat inserts to (machined) mount flange surface (distance in inches): | 6.060-6.064 |
| Intake valve minimum overall length: (inches) | 4.041 |
| Exhaust valve minimum overall length: (inches) | 4.056 |

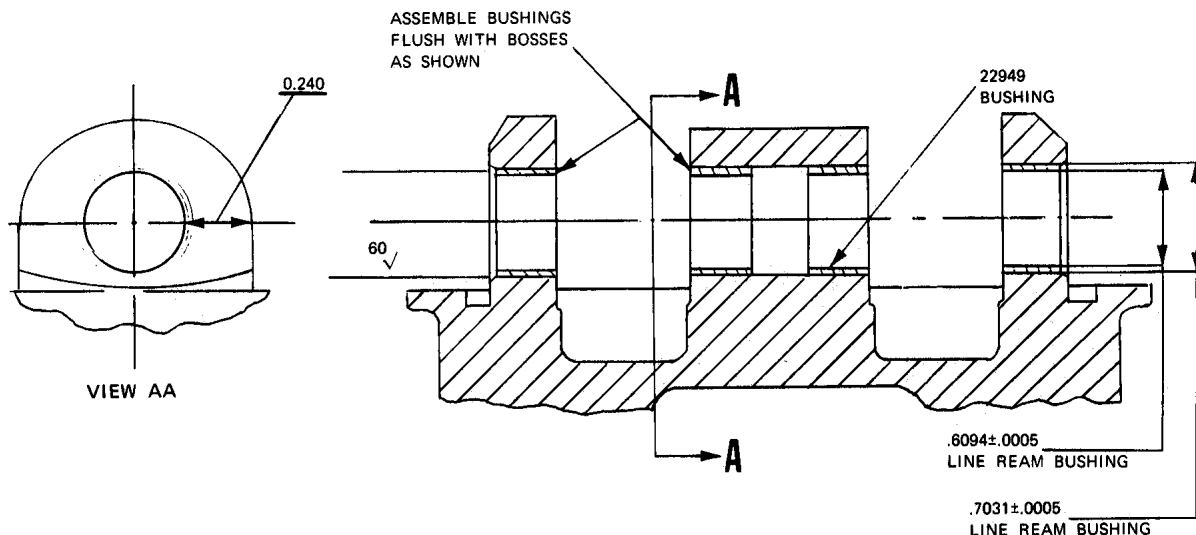

Figure 22. Dimensions of Rocker Shaft Boss Bushings

The difference in angle between valve and face permits lapping the valves to a single ring contact. The ring must be very narrow, but complete. Use fine grade lapping compound, and remove all traces of the abrasive before testing.

- g. If the rocker shaft is excessively loose in the cylinder head support bosses they may be brought back to standard size by boring or reaming in line and installing repair bushings. The center line of the enlarged boss bores must be 9.901-9.911 inches above the cylinder base flange mounting surface, in order that the reamed bushing bores will maintain the same distance. This dimension is important, because variations in spacing of the rocker axis from the camshaft will change the mechanical clearance in deflated valve lifter units and may make them inoperative. The minimum boss wall thickness measured at the edge of the center boss prior to any reaming and bushing must be 0.240 inch. The bore surface must be 60 RMS after reaming. (See Figure 22.)

14-9. CRANKSHAFT

In addition to the normal stoning and polishing operations, the following operations may be performed if appropriate equipment is available.

- a. Replace damaged propeller bolt bushings of flanged crankshafts by driving out the old bushing with a drift piloted in the bushing hole and pressing in a replacement bushing with a screw type puller. When driving a bushing out, support the propeller flange near the bushing location. An arbor press may be used to advantage in this operation. The puller screw should fit the bushing thread (3/8-24). A satisfactory puller may be made with a hardened screw, squared at the front end for a wrench, a puller nut, a thrust bearing and a sleeve to bear on the crankshaft propeller flange. The screw is inserted, from the front, through the bushing hole. Dip the bushing in engine oil and screw it on the puller screw behind the flange. Pull the bushing into the hole with its rounded flange corner toward the crankshaft.

- b. If main journals and crankpins are worn beyond limits of serviceability for standard size crankshafts they may be reground to .010 inch undersize and the crankcase and connecting rods equipped with undersize bearing inserts. Reground crankshafts must meet the following specifications:

1. Main journals and crankpins must not taper more than .001 inch, and any taper must be uniform from end to end.
2. No main journal or crankpin may be out-of-round more than .0005 inch or have flat spots or tool marks.
3. Radii of main journal fillets must be 5/32-11/64 inch.
4. Radii of crankpin fillets must be 11/64-3/16 inch.
5. All crankpin and main journal fillets must be tangent to the journals and each must be of uniform curvature, without tool marks or flat spots, all around. The shoulder between fillets and crankcheeks must not be removed.
6. All journals and crank pins must "clean up" within the undersize limits specified in Section XVIII.
7. All crankshafts which were originally nitrided must be renitrided after grinding. After nitriding, the run-out limits of new crankshafts must be maintained.
8. Surface finish on reground cranks shall be 6 RMS on all bearing journals and crankpins. Exercise care in polishing to maintain concentricity.

14-10. CONNECTING RODS

Piston pin bushings which are worn to give a clearance with the mating pins in excess of the serviceable limit specified in Section XVIII, or which are scored or burned, must be replaced with new, standard bushings. The original types of bushing used in C75, C85 and C90 connecting rods were solid rings. The bushings used in current

production are single piece, split rings. Either type of bushing may be used for replacement. Bushings for C90 and O-200 models are of different length from those supplied for C75, C85 connecting rods. Press out the unserviceable bushing with a shouldered driver whose pilot will fit closely, but not tightly, in the unfinished bore of a new bushing. The same tool will serve to press in the replacement. The pilot and shoulder of the driver must be machined square with each other, and the O.D. must clear the rod end bore. The rod end must be supported on a ring whose bore will clear the old bushing. For pressing in the new bushing the rod may be supported on the same ring or on a flat plate. Dip the new bushing in engine oil before installing. If the bushing is split, the split line must be located at an angle of 45° from the rod axis toward the big end and on the side opposite the numbered bolt bosses. Press the new bushing in squarely to avoid peeling off its surface. The new bushing must be reamed or bored to a finished diameter within the limits stated in Section XVIII, No. 21. The finished bore must not be more than .0005 inch out-of-round or tapered more than .0005 inch in its length. The centerline of the finished bushing must be 6.373-6.377 inches from the centerline of the crankpin bearing seat bore. In order to maintain this degree of accuracy, it is necessary that reaming be performed in a suitable fixture which will pilot both the big end bore and the reamer. When the volume of work permits, and when equipment is available, a more satisfactory bushing finish can be obtained by diamond point boring. The big end should be clamped on an arbor in the boring machine and the arbor indicated parallel in all planes with the boring bar. The center to center distance of bearings, mentioned above, must be established at the same time. Both ends of the bushing must be finished square and flush with the connecting rod boss. After reaming or boring, the rebushed rod must be inspected for bushing diameter, taper, out-of-round, bearing center distance, twist and convergence. Twist (out-of-plane) and convergence of bearing seat and bushing bore must not exceed .001 inch per inch of length.

NOTE

Connecting rod assemblies are balanced in sets with a maximum difference in weight in any engine of 1/2 oz. per pair in

opposite bays. If new or reconditioned rods are purchased the weight limit must be maintained. In ordering single replacement connecting rods, specify maximum and minimum permissible weights.

14-11. PISTONS, RINGS AND PINS

Repair small nicks in piston heads by dressing with a hard Arkansas stone. Dress light scores in skirts in the same manner and polish lightly with dry crocus cloth.

CAUTION

Stone and polish piston surfaces only enough to remove upstanding metal. Scratches cannot be removed without reducing excessively the dimensions. If large nicks or scores are found replace the piston. Do not use wire brushes or buffing wheels.

Replace removable piston pin end plugs with new parts if they are excessively worn on the heads or loose in the pins. If the heads of pressed in plugs are excessively worn or scored the pin and plug assembly must be replaced with a new part. Piston pins must be polished with crocus cloth dampened in kerosene while revolving at high speed. Finish with dry crocus cloth. Pins equipped with removable end plugs may swell slightly in service. Polish these to obtain the correct fit in piston bores. After Magnaflux inspection, the polished pins must be re-inspected for cleanliness, diameter and nicks.

14-12.

Replace all piston rings with new parts at each overhaul. Piston rings are sold only in complete sets, each set containing the correct number and types of ring for one engine. Ring sets are available in standard size, .005 inch-oversize and .015 inch oversize. If cylinder bores are less than .005 inch oversize use standard size pistons and rings. If the bores are .005 inch oversize, or very slightly more, use standard pistons and .005 inch oversize rings. If cylinders are ground to .015 inch oversize, use the same oversize of pistons and rings.

NOTE

The set of pistons for each new engine is selected so that the maximum difference in weight does not exceed 1/2 oz. per pair in opposite bays. This limit must not be exceeded when replacements are made. When ordering single pistons, specify maximum and minimum permissible weights.

14-13. CRANKCASE AND COVER ASSEMBLY

Dress any nicks in machined surfaces by stoning. Replace any loose, bent, stripped, nicked or broken studs. Carefully chase any damaged threads in holes for oil screen, oil pressure relief valve cap, oil plugs or tachometer drive housing (-8 models). Remove by stoning any burrs on threads of oil pressure relief valve cap, oil screen cap, oil pump suction tube or tachometer drive housing. Examine oil pump impellers, cover and chambers in the casting. If the chambers or cover are badly scored or if wear has increased impeller clearances beyond serviceable limits the damaged part must be replaced. If impeller tooth profiles are badly worn, scored, nicked or burned, or if the impeller driving square is noticeably worn, both impellers must be replaced. Replace the tachometer drive housing oil seal at each overhaul. Check seating of the oil pressure relief valve. If it does not seat perfectly the cover casting seat must be lapped with the plunger, the latter being guided in an old valve cap which has been bored through for the purpose. Remove all lapping compound. If a -12, -14, -16 or O-200 model oil screen housing flange is warped, lap it flat. Also lap the oil pump cover to a flat rear surface. If camshaft bearings are worn beyond serviceable limits they may be line bored or reamed to .020 inch oversize and an oversize camshaft installed. It is most important that re boring of camshaft bearings be done without shifting the camshaft centerline in any direction. The crankcase must be firmly clamped together during this operation, and the finished bores must be 1.3945-1.3955 inches in diameter. Lap the parting flanges of pushrod housing adapters, fuel pump pad cover and oil cooler pad covers (if used) to flat surfaces.

14-13A. STARTER CLUTCH AND CRANK-SHAFT MODIFICATION

A change has been incorporated in the O-200 crankcase and starter jack to extend service life by providing positive lubrication to the starter clutch.

New parts are available through normal channels to accomplish the revisions. Parts affected are the crankcase, starter jack shaft and bearing. See parts catalog X30011A for appropriate part numbers.

Special tooling has been designed so this modification can be accomplished in the field. This tooling is available from the Burroughs Tool and Equipment Corporation, 2429 North Burdick Street, Kalamazoo, Michigan 49007. Instructions for the use of this tooling are as follows:

Bearing-Bushing Drill Fixture, Burroughs P/N 8094B. (See Figure 23)

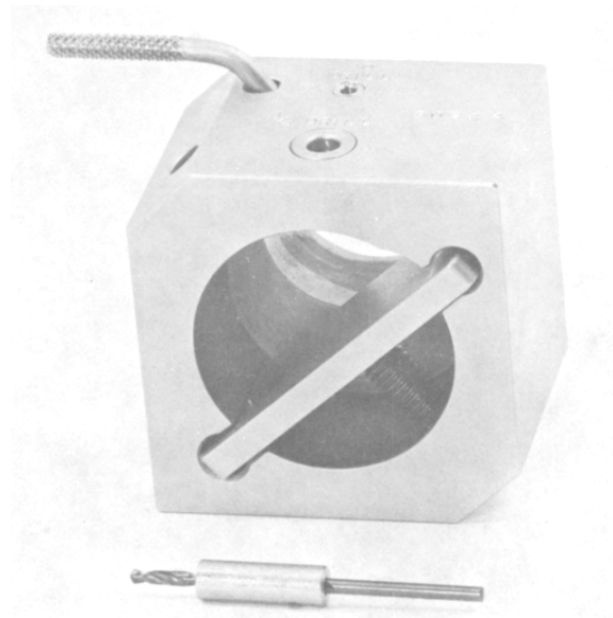

Figure 23. Drill Fixture

- a. Drilling rear main bearing.
 1. Back off allen set screw and remove flat retaining bar from center of tool.
 2. Insert bearing shell with index tab toward inside of tool and set shell into fixture so side of bearing is bottomed out in fixture bore.
 3. Insert retaining bar between bearing shell and Allen set screw. Turn in Allen set screw so bearing shell is held firm.

4. Put fixture in vise to hold securely. Drill hole in bearing with 1/4 inch drill the bushing in fixture. (See Figure 24.)

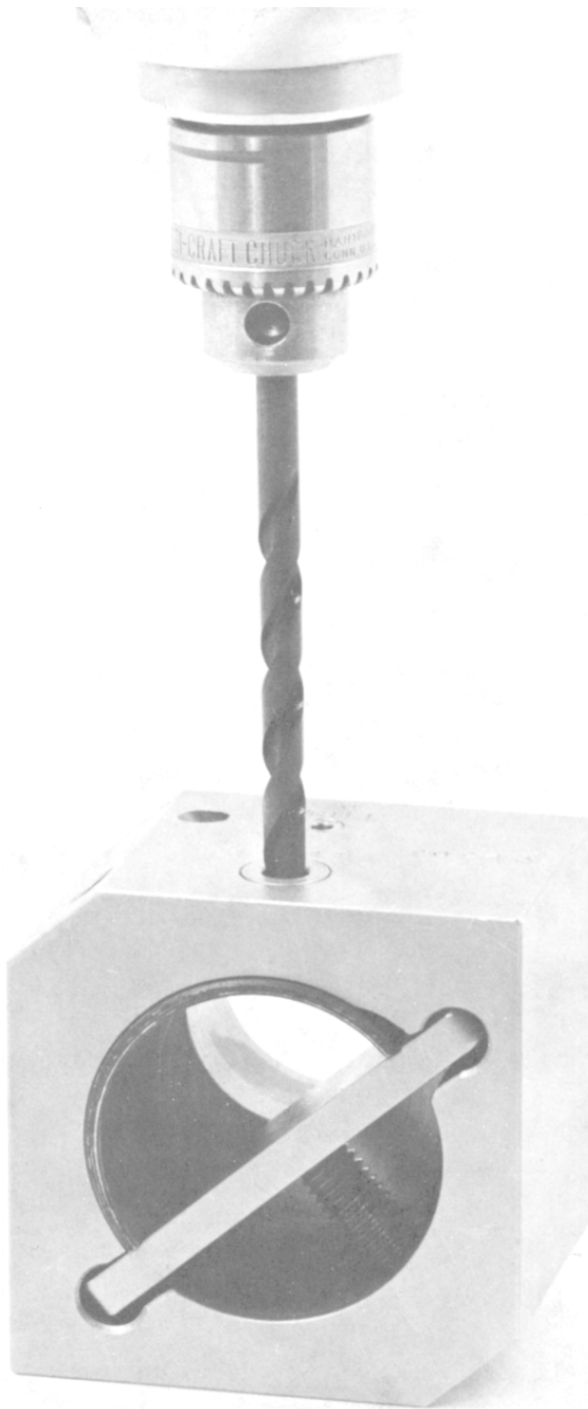

Figure 24. Drilling Hole in Bearing

5. Remove retaining bar and punch out bearing with a drift thru the hole in the 45 degree bevel.
- b. Drilling adapter assembly starter jack shaft PIN 634461 (See Figure 25)

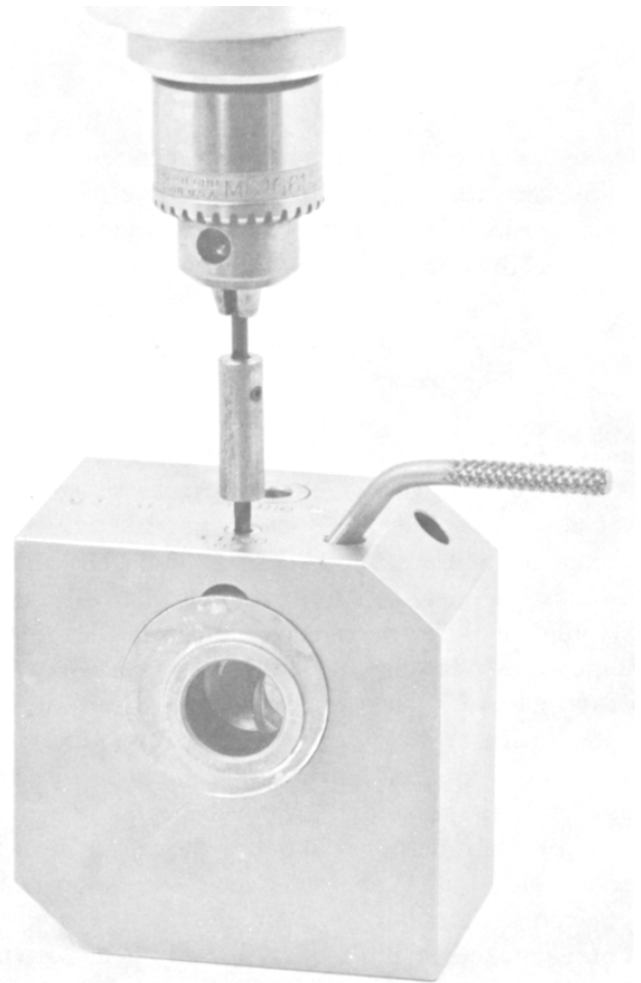

Figure 25. Drilling Adapter Assembly

1. Insert adapter into fixture with flat end first and index hole lined up with lock pin hole.
2. Lock adapter in place with lock pin.
3. Drill 1/8 inch hole until stop on drill bottoms on drill bushing. Drill speed to be 2500 - 4500 RPM. Drill length from tip to stop to be 0.625 inch.
4. Use drill press for following operation. Drill remaining distance with a No. 60 drill (0.040 dia.). This operation forms the orifice to restrict oil flow. Minimum length of 0.040 inch diameter hole is 0.125 inch. Drill speed to be 6000 to 10,000 RPM. Back off drill often to clear flutes.

CAUTION: Wear eye protection during all operations. Use cutting oil to prolong drill and fixture life.

5. Plug 0.500 inch dia. hole in back of adapter with 0.500 dia. x 0.375 inch long aluminum bar stock. Stake securely in place. (See Figure 26)

WARNING: Use care in staking plug in adapter hole to preclude plug being forced out into the engine, since oil to the adapter will now be under pressure.

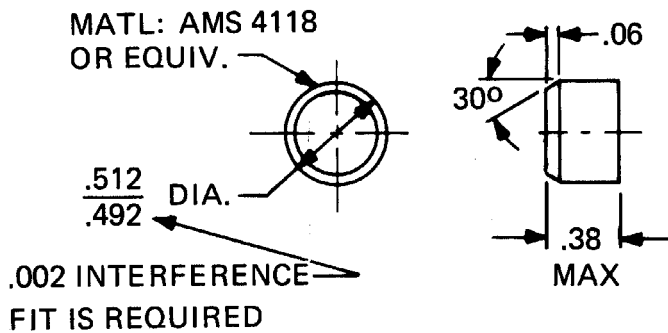
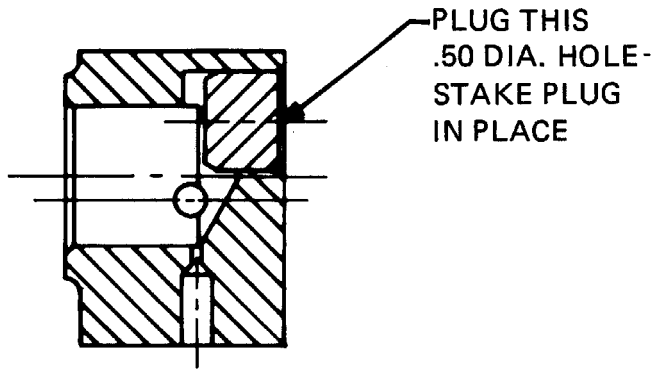

Figure 26. Plug Detail

- c. Drill fixture, Borroughs P/N 8094A. (See Figure 27)

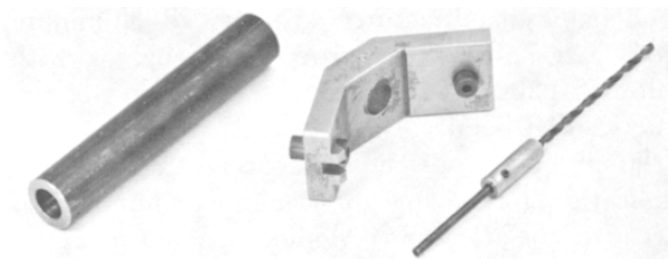

Figure 27. Drill Fixture.

1. Remove two thru studs on either side of the rear camshaft boss.
2. Install drill fixture over remaining stud at rear crankshaft boss. Align guide points of fixture so they straddle the index pin. (See Figure 28)

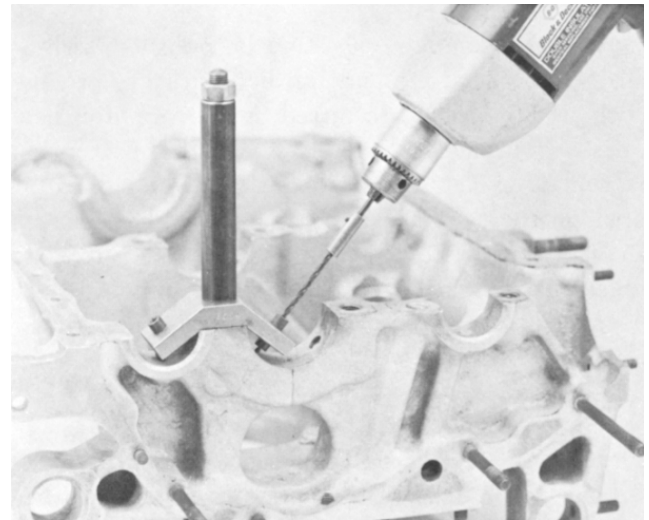

Figure 28. Drill Fixture Installed

3. Place spacer tube on stud and lock down with cylinder base nut.
4. Check drill to sleeve stop distance. Exposed drill should measure 2.625 inches to tip.
5. Drill hole into crankcase web until drill stop bottoms on fixture bushing. Pull drill back frequently to clear flutes. Use 2500 -4000 RPM drill speed. Repeat drill process in other bushing, Use cutting oil to prolong drill and fixture life.
6. Remove drill fixture and check with compressed air not to exceed 30 psi to make sure the holes meet inside the crankcase.
7. Reinstall studs removed in step 1.

When modification has been performed on crankcase, the letters "SO" must be stamped after the serial number (See Figure 29) Record modification in Engine Log Book.

| | | | | | |
|-----------|----------------------|------------|----------------------|--------|----------------------|
| MODEL | <input type="text"/> | TC | <input type="text"/> | PC | <input type="text"/> |
| H.P.-T.O. | <input type="text"/> | RPM | <input type="text"/> | MAG | <input type="text"/> |
| H.P.-M.C. | <input type="text"/> | RPM | <input type="text"/> | TIMING | <input type="text"/> |
| FUEL | <input type="text"/> | GRADE MIN. | <input type="text"/> | R. | <input type="text"/> |
| SER. NO. | <input type="text"/> | | SO | L. | <input type="text"/> |

"SO" TO BE STAMPED OR ETCHED AFTER SERIAL NO. IN THIS AREA

Figure 29. Name Plate Change.

14-14. CAMSHAFT

Light scoring on journals may be polished with a hard Arkansas stone and finished with dry crocus cloth. If cam lobes are pitted or worn or if either lobes or journals are severely scored the shaft must be replaced. Replace any camshaft which has no taper on the toe line of any cam lobe. This taper is necessary to rotate the valve lifters. Make sure that replacement is made with a shaft of standard size or oversize, as required to fit the crankcase bearings.

14-15. HYDRAULIC VALVE LIFTERS

Lifter parts are not repairable, and any part which is damaged or unserviceable, due to wear, must be replaced. New lifter bodies may be installed with used hydraulic units if nicked, pitted, scored, grooved or broken bodies must be replaced. Hydraulic units must be replaced if either the cylinder or plunger of the old unit is damaged or worn. These parts are not interchangeable. Pushrod sockets may be replaced independently of other lifter parts if the cups of old parts are excessively worn.

14-16. OIL SUMP

Small leaks in oil sump seams may be repaired by brazing, after thoroughly cleaning and drying the sump. Lap the mounting flange to a flat surface, and remove all lapping compound. If necessary, retap the 5/8-18 drain plug holes, and replace the plug if its hex or thread is damaged. If the plug lockwire clip is broken off a new clip should be brazed to the sump.

14-17. INTAKE TUBES

Straighten small dents in tubes by tapping with a non-marring hammer, while the tube is supported on a mandrel. Make sure that tube ends are perfectly round.

14-18. GEARS

Dress any small nicks with a hard Arkansas stone or with a fine India stone. Do not attempt to correct scoring or roughness on gear tooth faces. If tooth profiles are noticeably worn or if the teeth are chipped, burned, scored, burred or deformed in any way the gear must be replaced. Gear retaining screws must be replaced if they are stretched or otherwise deformed.

14-19. AIR SCOOPS AND INTAKE HOUSINGS

These sheet metal parts may be repaired in minor ways by brazing and straightening, however any serious damage makes replacement with a new part necessary. Lap mounting flanges flat, if necessary, and adjust plate valves to assure free operation and full closing.

14-20. VACUUM PUMP ADAPTER

Replace any loose, bent, stripped or broken stud. Clamp the adapter (pump mounting pad up) between soft shielded vise jaws. Engage jaws of an oil seal puller behind oil seal case and pull the seal. Smooth the adapter counterbore with crocus cloth, if necessary. Examine adapter bushing dimensionally. If worn beyond the serviceable limit specified in Section XVIII, and an accurate arbor press and boring machine are available, bore out the bushing to a thin shell and collapse it for safe removal. Support the adapter, pump mounting flange down, on a smooth parallel faced metal block. Lay combination of plate and adapter on an arbor press. Dip new bushing in engine lubricating oil and place it on a pilot arbor. Center bushing on adapter bore and press in carefully until fully seated. Remove adapter and plate from arbor press and fasten the combination of adapter and plate in a drill press. Ream bushing to a diameter of 0.8145 to 0.8155 in. Flange and bore must be concentric, flat, square and true to adapter to engine mounting face within 0.002 in. Coat a replacement seal with engine lubricating oil. Place adapter in arbor press with oil seal counterbore upward. Lay a new seal on adapter with sealing lip downward. Press seal squarely into counterbore until seated.

14-21. PROTECTIVE COATINGS

14-22.

The engine manufacturer protects all aluminum alloy parts of current production engines with "Alodine 1200". This material is a product of the American Chemical Paint Co., Ambler, Pa. Although the protective coatings differ, the application, interchangeability and part numbers of parts are not affected. "Alodine" coated parts are easily distinguished by their gold color. In order to maintain a uniform appearance, the manufacturer is painting exposed steel and magnesium parts with gold heat resisting enamel. Refer to the parts catalog for part numbers of gray, black and gold enamel.

14-23. REFINISHING ENAMELED PARTS

If enamel was removed from any exterior part by cleaning, etching or in the course of other repair work, it should be replaced with a new coat of primer and a finish coat of baked engine enamel of the proper color. The primer coat should be Zinc Chromate Primer, preferably applied by spray. After the primer coat has dried the finish coat of engine enamel should be sprayed to cover the primer, but not heavily enough to cause runs or drips. Ferrous parts when painted with gold enamel will be baked with infrared equipment for 15 minutes at 275°-285° following application of each coat. Magnesium parts will be pickled and primed; then baked in the same manner as ferrous parts.

NOTE

If a part which was originally "Alodized" is to be refinished with enamel, it will not be necessary to apply zinc chromate primer except to the surface areas completely stripped of "Alodine".

CAUTION

Before application of primer and enamel to a part, carefully mask all connection joints and mating surfaces. No primer or enamel is permissible on interior surfaces of fuel pump adapter, tachometer and oil pump housing, oil sump, crankcase or any other parts contacted by engine lubricating oil after assembly.

14-24. "ALODIZING" AND REPAIR OF "ALODIZED" SURF ACES

Aluminum alloy castings, sheet metal and tubing are protected from corrosion by treating all surface of the parts with "Alodine 1200" (American Paint and Chemical Co., Ambler, Pa.). "Alodine", unlike enamel or primer, will not flake or peel off to contaminate engine lubricating oil; therefore, corrosion protection can be afforded to all interior aluminum surfaces and parts. If an enamel coating is required for a part previously treated with "Alodine", application of a primer before painting is not necessary. "Alodizing" will be performed after all machining and/or repair operations have been completed. The surface color of an "Alodized" part may vary from light gold to dark brown. When a part is treated with "Alodine 1200" the thickness of the film, or buildup, on the mating or

bearing surfaces is so fine that the effect on dimensional tolerances is negligible.

14-25. APPLICATION OF "ALODINE 1200"

In the event the original finish of an aluminum part has deteriorated or been removed, the part may be "Alodized" as described in "Alodine" manufacturers Technical Service Data Sheet No. AL-1200-D. Wrought or die cast (smooth surface) parts, such as valve rocker covers and intake tubes, should be tumbled or sand blasted to roughen before treatment.

14-26. REPAIR OF ALODIZED SURFACES

If "Alodized" parts have been remachined, rubbed with abrasives or scratched in handling so as to expose areas of bare aluminum, the surface may be repaired by local application of "Alodine" solution in the following steps:

- a. Clean the parts' bare area thoroughly with carbon tetrachloride. Do not under any circumstances use an oil base solvent such as General Specification. P-S-661, TT-291 or alkaline cleaner.
- b. Mix a small quantity of hot water (180°F) with 1-1/2 to 2 ounces of "Alodine 1200" powder to form a paste, then gradually dilute with hot water until a solution of one gallon is attained. This solution is to be adjusted with nitric acid addition to a PH value of 1.6 (1.5 to 1.7).
- c. Application shall be made, with a rubber set paint brush, in a manner so the solution flows over the area.
- d. Allow solution to remain on the part from one to five minutes or until color of the new film is approximately the same as the original.
- e. Flush part with clear water and dry with air. Do not blast or rub with cloth to dry new film area. If color is too light, repeat steps "c" and "d" until desired color is obtained.

NOTE

If "Alodine" does not adhere to metal, a more severe cleaning method must be used. A solution of 12 to 16 ounces of Oakite No. 61 per one gallon of water is preferred. Apply and remove the solution with caution because an alkaline cleaner of this type will remove any "Alodine" film previously applied. Remove cleaning solution thoroughly with plenty of hot water and vigorous brushing.

14-27. IGNITION CABLES

Refer to paragraphs 10-18, 10-19, 10-20, 10-21, and 10-22 for repair and replacement instructions.

14-28. DELCO-REMY STARTER

Refer to paragraph 10-29 for testing data.

14-29. PRESTO LITE STARTER

Refer to paragraph 10-35 for testing data.

14-30. DELCO-REMY GENERATOR

Refer to paragraph 10-38 for testing data.

14-31. STROMBERG NA-S3A1 CARBURETOR

For overhaul instructions, address Aircraft Technical Service, Bendix Products Div., Bendix Aviation Corp., South Bend, Indiana.

14-32. MARVEL-SCHEBLER MA-3SPA CARBURETOR

For overhaul instructions relative to these carburetors, address Service Department, Marvel-Schebler/Tillotson Division, Borg-Warner Corp., 2195 South Elwin Road, Decatur, IL 62525. C90 carburetors are identified by manufacturers part no. 10-4252 and the 0-200 carburetors by part no. 10-4115.

14-33. MAGNETOS

For Bendix magneto instructions, address Bendix Magneto Div., Bendix Aviation Corp., Sidney, N.Y. For Eisemann magneto information, address Jack & Heintz Precision Industries, Cleveland, Ohio. For Slick magnetos, write Slick Electro Inc., Rockford, Illinois. For Slick Magneto instructions, address Slick Electro Inc., 530 Blackhawk Park Ave., Rockford, Illinois 61101.

SECTION XV

ASSEMBLY OF SUBASSEMBLIES

15-1. GENERAL PROCEDURE

15-2. CLEANING AND LUBRICATION

Immediately before assembling the parts of any subassembly they should be sprayed with clean solvent to remove corrosion-preventive oil and grit. The parts should be dried with a blast of dry compressed air. All bare steel surfaces, bushings and bearings must be coated generously with a mixture of one part corrosion-preventive compound, of a type which will not adversely affect the lubrication system, and three parts of engine lubricating oil, if the engine will not be tested immediately, or the surfaces may be coated with clean engine lubricating oil if the test is to be performed at once.

15-3. NEW PARTS REQUIRED

All lockwire, palnuts, lockwashers, elastic stop nuts, gaskets and rubber connectors used in assembling the engine must be new parts. If any of these parts are removed after initial assembly it must be discarded and another new part installed. Sets of gaskets and rubber connectors, piston ring sets and main bearing and thrust washer sets for the various models are listed in the Parts Catalog. New sets of these parts for the model to be assembled should be procured in advance. All other new parts required for replacement of those discarded should be on hand.

15-4. DETAILED PROCEDURE

15-5. CRANKCASE COVER ASSEMBLY

Assemble parts in the following manner:

- a. Inspect the cover casting for any nicks or damage incurred in handling, for thorough cleanliness, condition of enamel or coating, freedom of machined surfaces and interior from enamel and any other irregularity.
- b. Install the pump impellers in their chambers, with the tachometer drive shaft end to the rear. Install the pump cover, and make sure that it fits perfectly on the chamber surface.

No gasket paste may be used in this joint. Place plain washers and bolts or slotted nuts on the pump studs and tighten to specified torque. Install lockwire to connect the studs or bolts in pairs. The lockwire must lie flat against the sides of bolts or nuts and must not pass over their tops.

NOTE

If the slots of any slotted engine nut or castle nut will not align with the stud hole when the nut is tightened to minimum specified torque, continue tightening until either the slot and hole align or the maximum allowable torque is reached, whichever occurs first. If alignment of the slots cannot be obtained within torque limits, substitute another serviceable nut.

- c. Test the oil pump impellers for free rotation. If any binding occurs, disassemble the pump for further inspection.
- d. Insert the oil pressure relief valve plunger in its guide; place the spring in the plunger; place a new copper-asbestos gasket on the cap, and screw the cap into the cover boss over the spring. Tighten the cap securely.
- e. Inspect the new oil seal in the tachometer drive housing. The seal lip must be outward. If the engine is a -8 model, place a new copper-asbestos gasket on the housing. Insert a strip of fiber in the tachometer drive shaft slot to fill the entire space and to protect the housing seal lip. Screw the housing into the left hand tapped hole over the tachometer drive shaft, being careful not to reverse the seal lip, and tighten the housing securely. Remove the fiber strip. If the engine is -12, -14, -16 or O-200 model the housing should be installed later.
- f. If the engine is a -12, -14, -16 or O-200 model prepare the oil screen housing gasket by working into its surfaces a small amount of non-hardening gasket paste. Place the gasket on the

crankcase cover pad. Place a new copper-asbestos gasket on the oil screen, and screw the screen into its housing loosely. Place the housing and screen on the crankcase cover gasket, and attach it temporarily with a plain nut. If the engine is a -8 model tighten the oil screen in its crankcase cover housing.

15-6. CRANKCASE

Install the following parts on the castings:

- a. Spread a light film of Led plate No. 250 on the two front oil gallery plugs, and screw them into the crankcase holes. Tighten both plugs securely.
- b. If no fuel pump is to be installed work a small amount of a non-hardening gasket paste into both surfaces of the pump pad gasket, and place the gasket and cover on the pad. Install two lockwashers and two plain washers and plain hex nuts. Tighten the nuts to specified torque.
- c. If the engine is a -12, -14, -16 or O-200 model, and if no oil cooler is to be installed, treat the cover pad gasket with non-hardening gasket paste, and place the gasket and cover on the small pad behind No.2 cylinder pad. Attach the cover with two plain washers, two lockwashers and plain hex nuts.
- d. Spread a film of Led plate No. 250 on the breather elbow thread, screw the elbow into the crankcase 1, 3 side boss ahead of No.3 cylinder pad. Tighten the elbow enough to prevent loosening. Position elbow 15 degrees rearward from its downward position on O-200 engines.
- e. Check the main bearing seats in both crankcase halves for nicks, and make sure that they are dry and clean. Place a new main bearing insert in each seat with the tang in the case notch and the ends projecting very slightly and equally above the parting surface. The flanged front main bearing inserts are used only on the O-200. Make sure that the set of inserts installed is the correct type for the crankcase being assembled

and of correct size for the standard or reground crankshaft to be installed. If there's an oil gallery for the starter clutch adapter, make sure the bearing shell has a hole and is properly installed.

15-7. CRANKSHAFT AND CONNECTING RODS

For maximum ease of working, the crankshaft, if a tapered type, should be held in a fixture, as illustrated in Figure 30. A fixture may be constructed for holding flange type shafts in the same position. Assemble parts as follows:

- a. If the shaft is a tapered type, screw the front oil plug into the front bore thread. For this purpose, a special type of screwdriver should be made to exactly fit the plug slot. The driver must have a wrench square or hex on its stem. Tighten the plug enough to hold oil, being careful not to damage the slot.
- b. Install the crankshaft in the holding fixture, and secure it.
- c. Layout the four sets of connecting rods, caps and bolts in numerical order, according to the cylinder numbers stamped on their bolt bosses.
- d. Insert two bolts in each rod bearing cap with the head flats against the cap shoulders.
- e. Obtain a set of new bearing inserts of the correct size for the crankshaft. Place an insert in each rod and cap. The inserts must seat fully, and their ends must project very slightly and equally above the parting surface.
- f. Coat the crankpins and bearings with engine oil. Install each rod and cap on the proper crank pin, according to cylinder numbers, and be sure that the numbers on rod and cap bolt bosses will be on top when the crankshaft and rod assembly is installed. Run on the slotted nuts as each rod is installed, in turn, and tighten to specified torque, and secure each with a cotter pin. Torque nuts to low limit. If cotter pin will not enter increase torque gradually up to high limit only. If cotter pin will not enter in this range replace nut and

repeat. In no case shall nuts be torqued below low limit or over high limit. (Refer to Section XVIII for Torque Limits.)

NOTE

When connecting rods and caps are installed correctly, the bearing cap squirt holes will point to the opposite cylinders.

CAUTION

With C90 and O-200 connecting rods, use only the bolts and nuts listed in the current Parts Catalog. Early production engines had longer bolts and taller hex nuts. These should not be used.

15-8. INTAKE PIPES AND HOSE CONNECTORS

Inspect all pipe ends for roundness. Obtain a new set of inner and outer hose connectors, and center one inner hose in each outer hose. Push the outer hoses on the ends of the pipes. Place two clamps on each connector. Tighten one clamp to hold one outer hose on each pipe securely. Push the opposite outer hose on each pipe backflush with the end of the inner hose, and tighten the remaining clamps only enough to prevent falling off.

15-9. INTAKE AIR FILTER

Obtain a new air filter of the proper type and a new gasket to match. Obtain four new locking studs and four cross pins. Insert the studs through the filter from the front side and through the gasket. Support the drilled rear end of each stud, in turn, and drive the cross pin through to centered position.

15-10. GENERATOR DRIVE

Refer to paragraphs 10-33 thru 10-36 for procedure and precautions to be observed in assembly of either type of generator drive.

15-11. OIL COOLER ADAPTER

If an oil cooler is used with the engine, spread a film of Led plate No. 250 on the three socket head pipe plugs. Install the 1/4 inch plugs tightly in the front and lower rear holes of the adapter, and install the 1/8 inch socket head plug in the bottom adapter hole. In the upper rear adapter hole insert the check

valve ball, then the spring. Place a new copper-asbestos gasket on the 5/8-18 hex head plug, and screw it in tightly on top of the spring.

15-12. MAGNETOS

Install the proper drive gear, according to the engine model, on the impulse coupling, or tapered shaft, of the two magnetos. Install the woodruff key before the gear on the tapered shaft of a right side Eisemann AM-4 magneto. Screw on the shaft nut tightly, and secure it with a cotter pin.

15-13. CYLINDERS

Assemble valves and springs in cylinders in the following manner, taking care to use the proper springs for the engine model.

- Lay the cylinder on its side. Coat each valve stem with a film of Shell grease, Alvania No. 2, and insert each valve through the cylinder and into its guide. Seat the valves, and check for correct positions.
- Lift the cylinder by the valve stems and place it on a fixture which will hold the valve heads on their seats.
- Place the two inner spring seats over the valve guides.

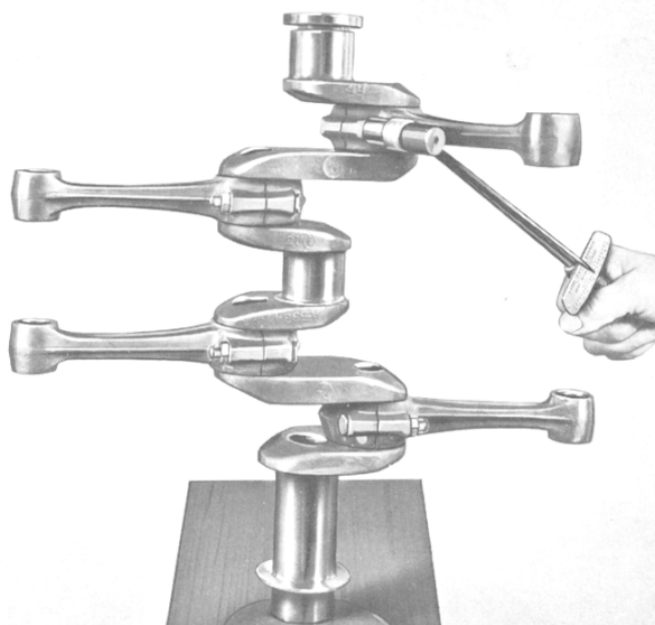

Figure 30. Tightening No. 1 Connecting Rod Bolts.

- d. Place the proper set of inner and outer, or inner, intermediate and outer springs over each valve stem.
- e. Place an outer spring retainer on each set of springs.
- f. If a lever type valve spring compressor is used, push the rocker shaft through its supports, and pivot the compressor on it.
- g. Compress either set of springs. Insert two locks in the valve stem groove, small ends inward, and release the springs. Make sure that the locks seat perfectly in the spring retainer and the stem groove.
- h. In the same manner, assemble the retaining parts on the other valve springs; then lift the cylinder from the fixture.
- j. Invert the cylinder, and place a new base packing ring on the cylinder skirt. Push it against the flange, and remove twists.
- k. Place two clamps and a new pushrod housing rubber connector on each housing, pushing connector back flush with the housing end.

15-14. PISTONS

Install C-90 and O-200 piston oil control rings with the pistons inverted on the bench. Install all other rings with the pistons upright. The upper side of each ring bears the part number. Be sure that the correct size rings for the cylinders are installed. Spread each ring, as it is lowered into position, to avoid scratching the ring lands. Install removable plugs in piston pins, and start the pins into their mating pistons.

15-15. PUSHRODS

Lay all pushrods in logical order in a pan of clean, light oil with crankcase ends raised to permit filling. Pushrods are numbered to avoid interchanging them at assembly.

15-16. VACUUM PUMP ADAPTER

Lubricate the gear shaft with engine oil; then push gear slowly into adapter. Use care when installing gear to prevent reversing oil seal lip.

CAUTION

Never exert lifting or other force on the pushrod housings. They must remain firm and tight in the rocker box.

- i. Slide out the rocker shaft, and install the two rockers in their original positions. Be sure to use the correct parts.

CAUTION . . . Exhaust rocker has an oil orifice in the valve stem end for valve stem lubrication.

SECTION XVI

FINAL ASSEMBLY

16-1. GENERAL PROCEDURE

16-2. ASSEMBLY STAND

The engine should be assembled on a stand equipped with a bed which can be rotated to place the No's 2, 4 cylinder side of the crankcase downward, so that the crankshaft and camshaft can be laid in place in the horizontal position, and can be turned to place the crankshaft in two vertical positions, with the front end of the shaft upward or downward. The stand should be constructed so that all sides and both ends of the crankcase are accessible, with sufficient clearance for installation of all parts and accessories.

16-3. NEW PARTS REQUIRED

Only new parts of the types named in paragraph 15-3 should be used in final assembly work, if removed for any reason, they should not be reinstalled.

16-4. DETAILED PROCEDURE

16-5. CRANKCASE AND ENCLOSED PARTS

Assemble and install parts in the crankcase in the following order:

- a. Attach the upper and lower mounting arms of the No's 2, 4 side crankcase casting securely to the assembly stand bed, and turn the bed so that the open side of the casting is upward.
- b. Place the No's 1, 3 side crankcase casting on the work bench, with the open side upward.
- c. On the parting flange contact surfaces of the castings, and on the small surface immediately below the rear camshaft bearing (around the 3/8 inch stud) spread a thin, uniform film of Aviation Permatex. Do not allow the liquid to run into the interior of the case. Do not apply Permatex on the other camshaft bearing bosses or on any main bearing bosses. Use it only on the surrounding flange and around the 3/8 inch stud.

- d. When the Permatex has become tacky, place a strand of No. 50, Grade "A" silk thread along the upper, lower and front flanges of the No's 2-4 side casting. Place the thread inside the upper and lower flange screw holes and inside the lower front flange hole. Place a loop of thread around the 3/8 inch stud on the surface below the rear camshaft bearing.
- e. In succession, dip each valve lifter body in light engine oil or in a corrosion-preventive oil mixture, and install it in its original crankcase guide from the inside. As each lifter body is installed in the 1, 3 side casting, push a used pushrod housing rubber connector over its outer end to prevent it from falling.
- f. If the engine being reassembled is a C90-16 or an O-200, a driving bevel gear must be installed on the front end of the camshaft before it is installed. Install gear on camshaft and install six retaining screws tightly. Safety the screws in three's with lockwire. Coat the camshaft with oil, and place it in the bearings of the crankcase 2, 4 side. Measure clearance between either camshaft rear bearing flange and the bearing end. (Refer to Section XVIII.)

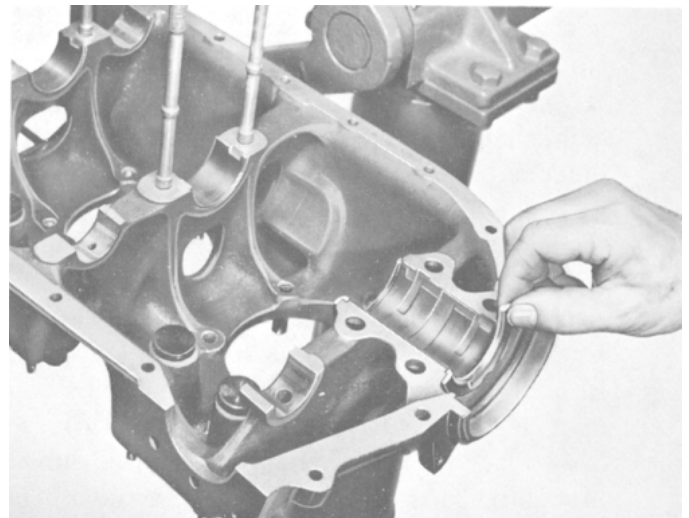

Figure 31. Installing Crankshaft Bearing and Old Type Thrust Washer

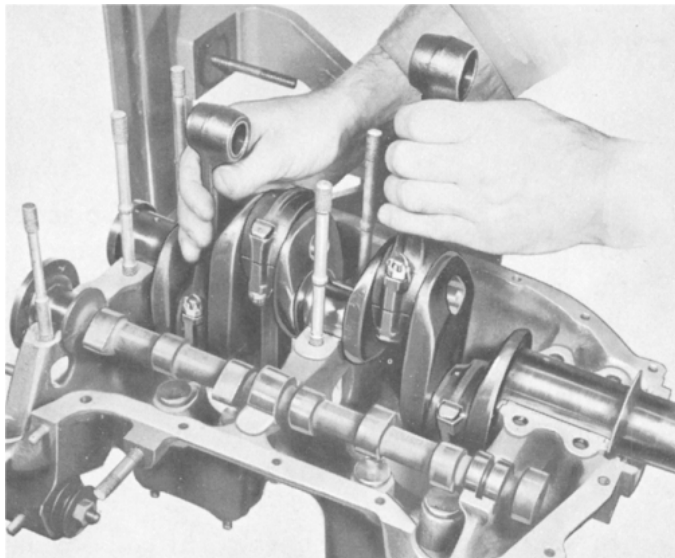

Figure 32. Installing Crankshaft and Connecting Rods.

CAUTION

Some early production O-200 engines require shims behind vacuum pump driving bevel gear. Reassemble original parts with same shims. Replacement parts may not require shims as determined by backlash. Refer to Section XVIII for proper backlash.

- g. Spread a very thin, uniform film of lightweight TiteSeal, or an equivalent gasket paste, on the surface of the recess around the crankshaft opening at the front of each crankcase casting. Coat the sealing lip of a new crankshaft oil seal with a film of Gredag No. 44, or an equivalent lubricant. If the seal is a split type assembly for a flange type crankshaft, remove the helical spring from its inner recess, and unhook the ends.
- h. If the crankcase is the older type, equipped with dowels in the front main bearing boss to retain the thrust washers, obtain new washers of the proper type, and spread a very thin film of soft grease on their shouldered sides, so that they will adhere to the ends of the boss. place each washer in position, as shown in Figure 31. Four identical notched washers are required.
- i. If a flange type crankshaft is to be installed, spread the split oil seal ends by twisting, and

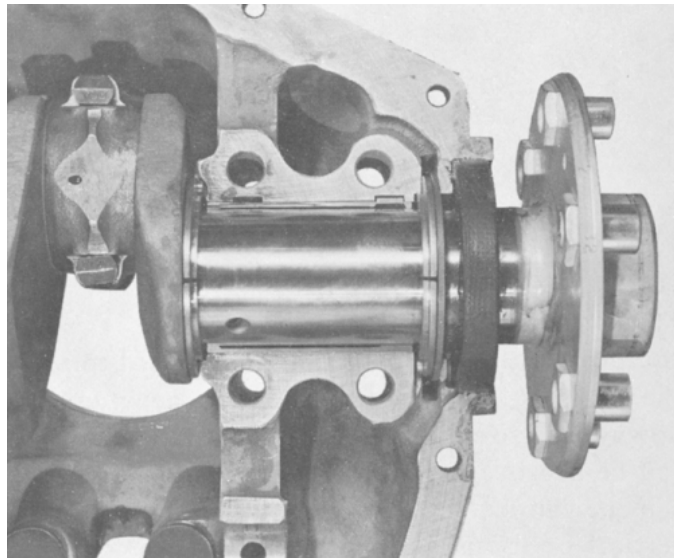

Figure 33. Installing Dowel Type Thrust Washers and Split Oil Seal.

place the seal on the shaft behind the propeller flange with its recessed side toward the rear. Pass the oil seal spring around the shaft behind the seal, and hook its ends to make a loop. Place the spring joint opposite the seal split. Lift the spring into the seal recess at one point, using a wire hook, and work the entire spring into the recess progressively. Make sure that the spring lies in the groove inside the recess.

NOTE

If a flange type crankshaft is to be installed in an old type crankcase (with small shoulder behind oil seal recess) a special spring (part number 25386) may be installed behind (and not touching) the oil seal to act as an oil slinger.

- j. Spread a generous coat of light engine oil or corrosion-preventive oil mixture on all crankshaft main journals. Lift the crankshaft and connecting rod assembly by the No's 1 and 3 rods, and place it carefully in the 2, 4 crankcase side bearings. If it is a flange type crankshaft turn the oil seal, before seating the shaft front end, so that the split will be within the 2, 4 side recess and 20° from the parting surface toward the top of the case. The seal must be against the shoulder of the recess. (See Figure 33.)

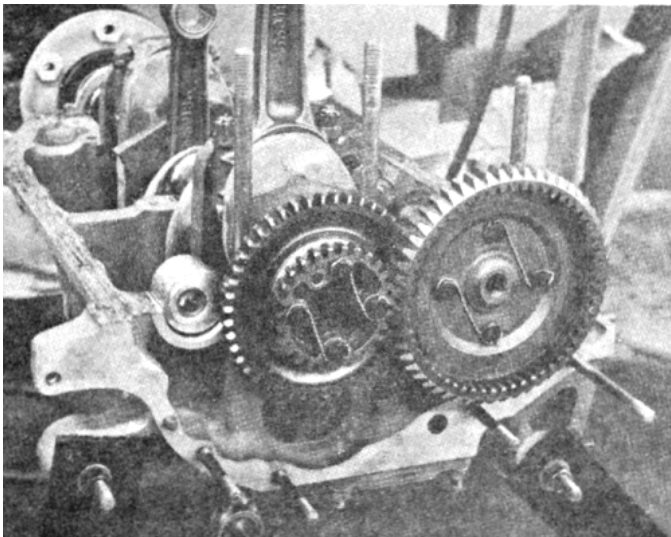

Figure 34.

Installing Adapter Electric Starting Engines.

- k. If the crankshaft is a tapered type, pass the steel cased oil seal over the front shaft end with its sealing lip toward the rear. Lift the shaft end slightly, and push the seal into the case recess as far as it will go, with its drain hole toward the camshaft.
- 1. Early crankcases for all "C" models are notched at the lower front and upper rear edges of the No. 2, 4 side front main bearing to accept the pins installed in two thrust washers. Obtain two plain thrust washers and two with the short dowels installed at the center. Slide the plain half washers into the 2, 4 side crankcase recess; then place the dowel half washers against the crankshaft thrust flanges, and rotate each complete washer until the short dowel lies in a crankcase notch. (See Figure 35.)

NOTE

On the O-200 the front and rear thrust flanges are manufactured on the front main bearing. Before torquing the through bolts or the backbone bolts, pull the crankshaft up against the rear of the front main bearing to seat the front main bearing to seat the thrust flange of bearing against the bearing support boss. Torque through bolts and backbone bolts.

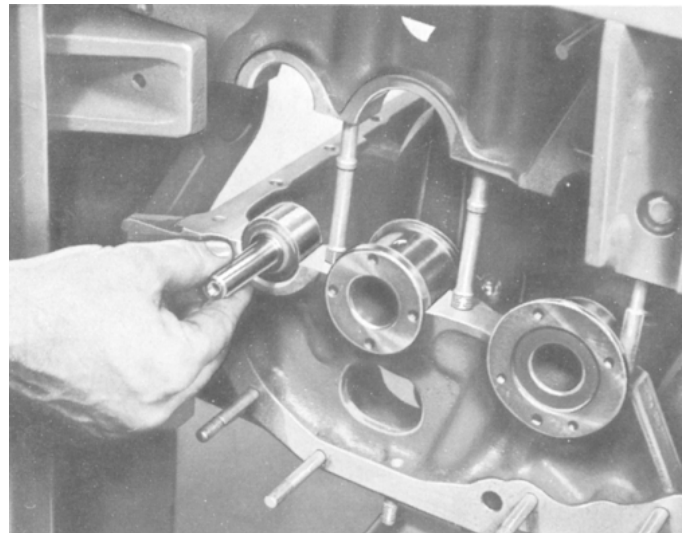

Installing Starter Pinion Pivot
Manual Starting Engines.

- The current "C" and O-200 models have the crankcase assemblies machined at the front main bearing bosses to accommodate a plain main bearing and flat, or tang-type thrust washers. Crankcases not machined for the above type thrust washers must use the available flange type main bearing.
- m. Insert a thickness gauge between the crankshaft front thrust flange and the thrust washer or between the front thrust flange and the flange of the front main bearing of the O-200. With the crankshaft drawn forward, measure the end clearance. (Refer to Section XVIII.)

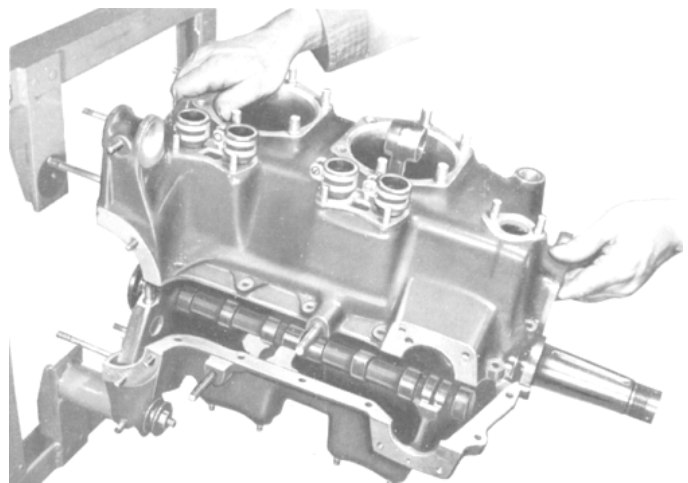

Figure 35 Installing Crankcase 1,3 Side on 2,4 Side.

- n. If the engine is a -12, -14, -16 or any early O-200 model, install the pinion pivot in its recess above the rear main bearing. If the engine is an O-200 using a Prestolite Starter, install the starter jackshaft adapter. (See Figure 34.) Make sure crankcase has been modified per para. 14-13 A.
- o. Place No's 1 and 3 connecting rods upright. Invert the 1, 3 crankcase side, and lower it carefully into place on the 2, 4 side, keeping the parting flanges parallel to prevent binding as the through studs in each casting pass through the opposite half.
- p. Make sure that the case parting flanges make contact all around. See that the starter pinion pivot is correctly seated and retained by the case dowel. If a split oil seal is installed, check position of the joint, and see that the ends are flush. Either type of seal must be against the rear shoulder of the recess, and the seal lip must touch the crankshaft at all points.
- q. Place a plain washer next to the head and install the three 5/16 inch dowel screws through the crankcase flange holes to align the case halves. In addition to the dowel screws, install the two through bolts in the O-200 crankcase and any C model whose crankcase is machined at the center bearing bosses to accept through bolts. If the engine is a -8 model, the dowel screws will all be the same length. For the -12, -14 or O-200 models the longer screw is installed in the second hole from the rear of the upper flange. Install a 1/4 inch hex head screw in the hole ahead of the upper flange dowel screw. Place a spacer washer on each of the upper flange screws, then the engine lifting eye. Secure the four screws with a plain washer and hex nut on all C models. On the O-200 models secure the two lifting eye attaching screws with a lockwasher and plain hex nut and the remaining two dowel screws with a lockwasher, plain washer and hex nut. Tighten the nuts moderately.
- r. Install protectors on all connecting rods to prevent the rods from touching the crankcase.
- s. Test the crankshaft and camshaft for free rotation. If they turn freely, attach the 1, 3 side mounting arms to the assembly stand.
- t. Place plain washers and hex nuts on the two front through studs ahead of No.4 cylinder pad and on the through stud above the lower right mounting arm. Tighten these nuts to specified torques for their respective sizes.
- u. Insert the two longer crankcase flange screws in the holes immediately ahead of the upper dowel screw on -8 models, then install the lifting eye spacers, the lifting eye, plain washers and attaching nuts. On all C75, C85 and C90 models install the remaining crankcase flange screws, with plain washers under their heads and secure them with plain washers and hex nuts. On the O-200 install the remaining crankcase flange screws, in the same manner as the other models and secure them with a plain washer, lockwasher and hex nut. Tighten all flange screws to the standard torque specified for 1/4 inch nuts and screws.
- v. Remove rubber connectors from the outer ends of 1, 3 side valve lifter bodies.
- w. If the engine is a C model and is to be equipped with a carburetor, and if the mount pad at the bottom front of the crankcase is machined and studded, install on the pad a gasket treated with light weight TiteSeal. Install either the lower fuel pump adapter, with its pump pad to the rear, or a cover plate. Attach the adapter or cover with spacers, if required, plain washers and castle nuts. Install lockwire to connect and secure the nuts in pairs. If the engine is an O-200 or C90-16, install a gasket treated with lightweight TiteSeal on the pad at the bottom front of the crankcase. Install the vacuum pump adapter. One stud set in the crankcase is larger in diameter than the other three. Line up matching holes in adapter and install the adapter. Secure it with three 1/4 inch plain washers, lockwashers and plain hex nuts and one 5/16 inch plain washer, lockwasher and plain hex nut.

16-6. GEARS AND CRANKCASE COVER

Rotate the engine bed so that the front end of the crankshaft is downward, and lock it in position. Install parts at the rear of the crankcase in the following order:

Rotate the engine bed so that the front end of the crankshaft is downward, and lock it in position. Install parts at the rear of the crankcase in the following order:

- a. Install the proper type of gear on the rear pilot of the crankshaft, and run in the four hex head screws with fingers.
- b. Turn the crankshaft until No.1 crankpin is at T.D.C. The gear tooth timing marks will be toward the camshaft.
- c. Turn the camshaft counterclockwise until No. 1 exhaust lobe (rear) approaches its closing position and No.1 intake lobe is beginning its lift. Install the camshaft gear on the camshaft pilot with its punch marked tooth meshed between the marked teeth of the crankshaft gear. Install four hex head retaining screws.

CAUTION

Use screws of correct length on each gear. Refer to Parts Catalog for lengths required by each model.

- d. Tighten the eight gear retaining screws to torques specified in Section XVIII.
- e. Install lockwire through the drilled heads of the retaining screws of both gears to connect them in pairs. The wire must pass around the sides of all screw heads, not over their ends, and it must be twisted in the direction necessary to prevent the end loops from rising and led from one screw to the next in the direction necessary to prevent either screw from loosening. Draw the twisted lockwire tight, and bend the twisted ends down.
- f. Work into both surfaces of the proper cover gasket a small quantity of a non-hardening gasket paste, and place the treated gasket over the studs and on the crankcase rear surface.

The dowel holes in the gasket must fit over the crankcase dowels.

NOTE

The cover gasket for -12, -14, -16 and O-200 model crankcase does not have or need a hole for the left oil gallery.

- g. Lower the crankcase cover subassembly over the studs, and seat it on the cover gasket, as shown in Figure 36, for -12, -14, -16 or O-200 models, turning the crankshaft slowly to align the oil pump drive.
- h. If the engine is a -12, -14, -16 or O-200 model place plain washers, lockwashers and plain hex nuts on all crankcase cover retaining studs, except the one through the generator mount pad. Tighten to specified torque these seven nuts and the third retaining nut of the oil screen housing. Loop a length of lockwire around the nearest cover retaining studs to the oil screen housing and oil pressure relief valve cap, and twist the wire. Twist the two lockwires and lead them to the oil pressure relief valve cap and the oil screen cap, respectively, in a counterclockwise direction to engage the cap corner holes. Install a drilled hex head plug and new copper-asbestos gasket in the oil screen cap hole. Tighten the plug, and secure it with the ends of the lockwire in the screen cap. If the engine is a -8 model install all of the ten retaining washers, nuts and safety the oil screen and pressure relief valve-cap in the same manner as described.
- i. With a sharp knife, cut out the strip of the crankcase cover gasket which crosses the oil sump pad opening, then trim the lower ends of the gasket flush with the sump mounting pad.

16-7. VALVE LIFTER UNITS AND PUSHROD HOUSING FLANGES

Rotate the engine bed so that the front end of the crankshaft is upward. Then:

- m. Install hydraulic units in the valve lifter bodies with their plungers outward. Before installing each unit, make sure that its spring is snapped into the cylinder counterbore and that the plunger can be depressed fully. Place the original socket in each lifter.

- b. Work a small quantity of a lightweight TiteSeal into both surfaces of each pushrod housing flange gasket, and place the gaskets on the crankcase pads. Place the housing flanges on the gaskets. Install plain washers and hex nuts on all studs of the C models. For the O-200, install a plain washer, lockwasher and hex nuts on all studs. Tighten the flange retaining nuts to specified torque.

16-8. PISTON ASSEMBLIES

Place each piston assembly with the mating cylinder, and preferably in numerical order. Before installing each piston, coat its skirt, rings and pin with a light mineral oil or with a corrosion-preventive oil mixture. If the pin has removable end plugs place them with the cylinder. Push the pin partially into the piston bore, but clear of the connecting rod cavity. Make sure that piston ring part numbers are toward the piston heads.

16-9. PISTONS AND CYLINDERS

Install these sub-assemblies as follows:

- b. Turn the crankshaft until No.1 connecting rod is at T.D.C., with both valve lifters on the heels of their cam lobes.
- c. Lay the cylinders on their sides, and coat the bores generously with light engine oil or corrosion-preventive oil mixture.
- d. Install No.1 piston with the cylinder number on its head toward the front of the engine. Push the pin through the connecting rod bushing to the centered position.
- e. Remove the protector from No.1 connecting rod. Hang the piston ring compressor on the connecting rod. Stagger the piston ring gaps 90° apart, with no gap in line with the pin.
- f. Hold No.1 cylinder on the left arm. Do not hold the pushrod housings. Take the two pushrods for No.1 cylinder from the oil pan, and insert them in the pushrod housings, seating their ends in the rockers. Make sure that each pushrod is in its original position.

- f. See that the No.1 valve lifter sockets are in the lifters. Make sure that No.1 cylinder base packing is not twisted. If removable piston pin plugs are used pick up the two for No.1 piston pin.
- g. With the right hand, apply the ring compressor to the No.1 piston rings above the pin. Push the cylinder skirt over the rings. Remove the compressor, and install the piston pin plugs. If the engine is a C90 or O-200 model, compress the bottom piston ring. Push the cylinder inward over the piston. Remove the ring compressor, and seat the cylinder on its crankcase pad.
- h. Install six flanged nuts on the cylinder base studs, and tighten them to specified torque.
- i. Fully depress each rocker of No.1 cylinder, in turn, and measure the lash in the -deflated valve train between the rocker and the valve stem. This lash must be .030-.110 inch. If the lash is excessive, either rockers, pushrods, lifter sockets or valves must be replaced.
- j. In the same manner, install No.2 cylinder, after turning the crankshaft one revolution, and check its valve lash.

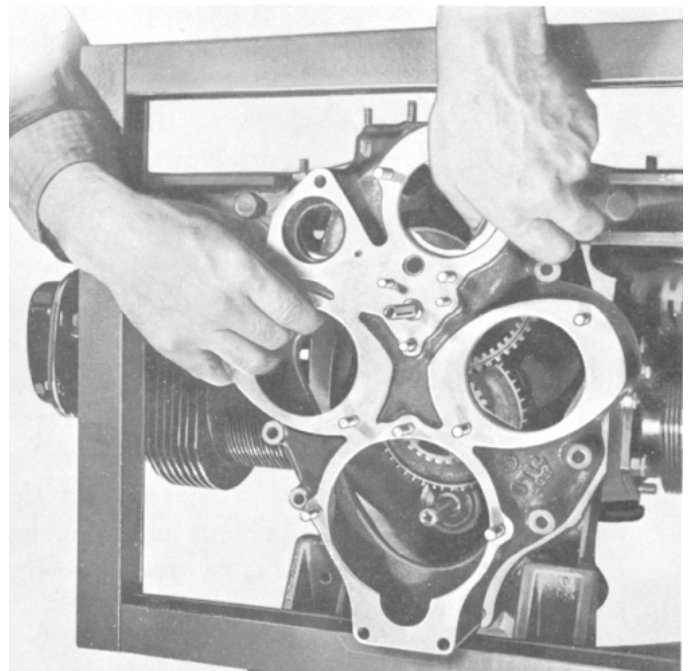

Figure 36. Installing Crankcase Cover on -12, -14, -16 and O-200 Models.

- k. Repeat the installation procedure for No's 3 and 4. cylinders, with the crankpin at T.D.C. and the valve lifters on the heels of the cam lobes in each case. Check lash in each of their valve trains.
- l. Treat each rocker cover gasket with lightweight TiteSeal and install each gasket and rocker cover on a cylinder head. Install plain washers, internal tooth lockwashers and fillister head screws in all covers.
- m. Push the rubber pushrod housing connectors inward over the flanges, and install a hose clamp in each connector groove.

16-10. AIR INDUCTION SYSTEM

Install parts required for the carburetor induction system, as required, in the following order:

- a. Place a new gasket on the studded intake flange of each cylinder head, and place the correct types of elbows on the gaskets. When correctly installed, the elbows point to the manifold attaching studs.
- b. Install lock-o-seal washers between the crankcase and intake manifold and below the intake manifold. When required, install the carburetor air box support assembly on the forward stud. Install castle nuts and tighten

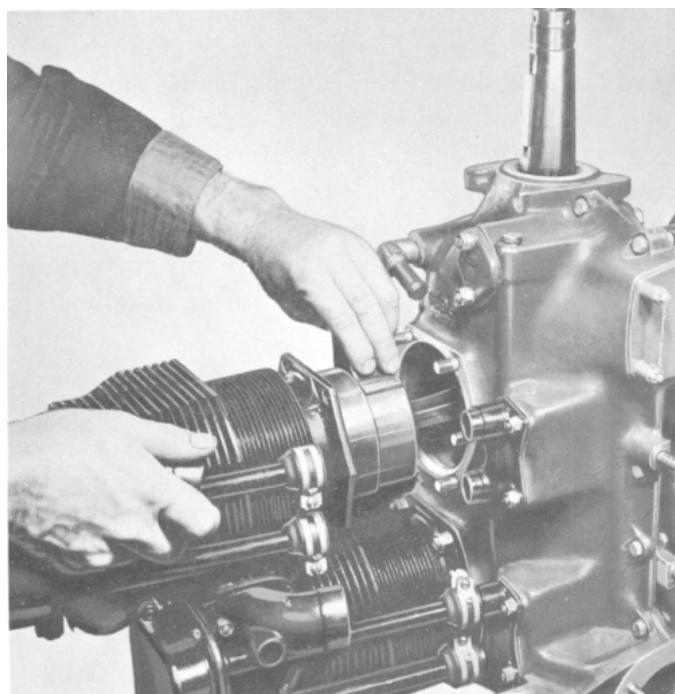

Figure 37. Installing No. 3 Cylinder.

finger tight. Advance as required to install cotter pin. Do not use wrench on castle nut. (See Figure 38.)

- c. Make sure that inner hoses are in position within the outer hose connectors at both ends of all intake pipes and that all hose clamps are in position. Push the projecting hose of each intake pipe over a manifold outlet, and push the hose connectors at the opposite ends over the cylinder intake elbows. Tighten all hose clamps to hold the pipes firmly.

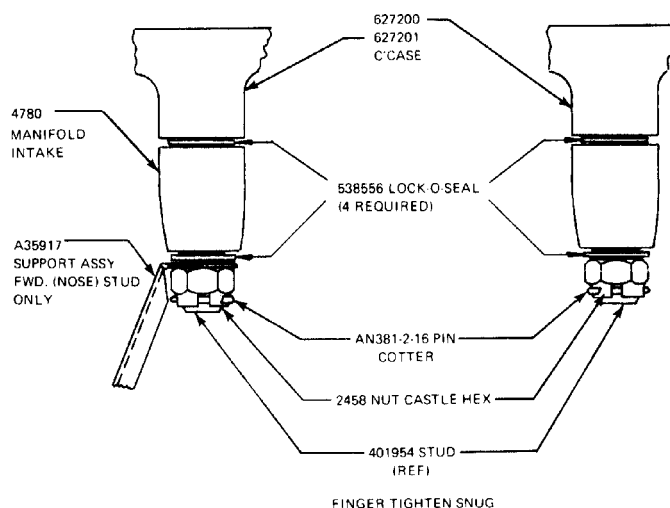

Figure 38. Install "O" Rings on Intake Manifold Studs.

16-11. CARBURETOR AND INTAKE HOUSING

If the engine is to be equipped with a carburetor make sure it is the right model for the engine being reassembled. Place a new gasket on the manifold lower flange over the four studs. Install the carburetor with its throttle lever on the right side, and attach it with four plain washers, lockwashers and hex nuts. In the same manner install and attach the air intake housing with its scoop forward. Be sure to install the proper housings since engines equipped with Marvel-Schebler carburetors require a different air intake housing. Refer to the Parts Catalog for applicable housing required. Attach the housing support under the manifold front retaining nut and to the housing with two fillister head screws.

16-12. AIR FILTER

Place the gasket assembled to the air filter against the flange of the air scoop or intake housing, and with the filter locking studs entering the locking plate holes. Press the filter firmly against the scoop and turn the four studs to lock.

16-13. OIL SUMP AND SUCTION TUBE

Make sure that the sump to be installed is the correct type for the engine model and for the aircraft installation; then proceed in the following manner:

- a. Place a new copper-asbestos gasket on the threaded end of the oil pump suction tube. Screw the tube thread into the crankcase cover hole within the sump mount pad circle, and tighten the hex. Install lockwire in the hole across a corner of the hex; twist it, and lead it clockwise to the nearest of two holes provided in the casting. Insert one end of the wire, and twist the two ends to pull the wire tight.
- b. Spread a thin film of non-hardening gasket paste on both surfaces of an oil sump gasket, and place it on the crankcase pad. Ascertain whether the sump filler neck should extend to the left or to the right side to suit the aircraft; then place the sump on the pad, and check the fit of the filler neck bracket on the lower mount arm. If it does not make contact install one or two plain

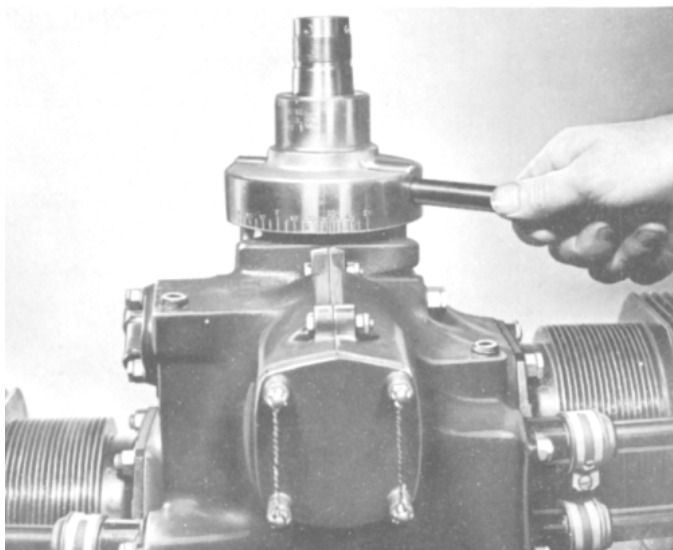

Figure 39. Placing Crankshaft in Firing Positions of No. 1 Piston.

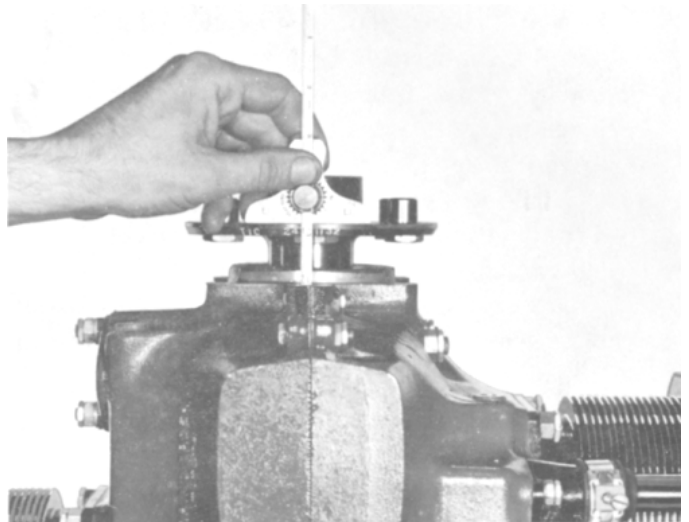

Figure 40. Placing Flange Crankshaft in Firing Position of No.1 Piston.

5/16 inch washers as spacers. Attach the sump and filler neck to crankcase plain studs with elastic stop nuts or to drilled studs with castle nuts and lockwire. Install the oil gauge and cap assembly.

16-14. IGNITION SYSTEM

Install on the two magnetos the proper type or types of gear for the engine model. Tighten the magneto shaft nut, and install a cotter pin to retain each gear. To install the magneto, turn the engine crankshaft in the direction of engine rotation until No.1 cylinder is in its correct firing position on the compression stroke (See Table X). Insert the magneto with the distributor rotor in position to fire No.1 ignition cable (after tripping the impulse mechanism if any). For the Bendix Magneto, timing to the engine is obtained by turning the magneto through the required angle until the breaker points just open. Use a timing light preferably. For the Slick Magneto only the removal of the timing key is required after installing the magneto on the engine.

- a. SLICK MODEL 4001 MAGNETOS. Current production Model O-200 engines are equipped with non-adjustable Model 4001 slick Magnetos. Remove the bottom vent plug and "Spark Out" the magneto. This magneto cannot be overhauled and the breaker assembly, coil and capacitor are non-replaceable. Exchange magnetos are available through your Continental Distributor.

To "Spark Out" the magneto, hold the lead with T1 or B1 on the spark plug nut 1/8" to 1/4" away from the magneto frame, and turn the impulse coupling or gear one (1) click at a time until a strong spark jumps between the wire and the magneto frame. Use care to hold the magneto firmly so the coupling will not move beyond the point where it trips and the spark occurs. Reverse the operation approximately 25° until the white line appears in the center of the hole. Hold the rotor with the index finger so the white line is in the center of the hole and install the magneto on the engine.

- b. For unshielded systems, install the front cable brackets on the front attaching bolt of the lifting eye. On -8 models, install the rear cable brackets under the outboard magneto flange nuts, and on -12, -14, -16 and O-200 models under the lower of two crankcase cover retaining nuts in front of each magneto. Install the upper ignition cable brackets of radio shielded systems under the upper center base nuts of cylinders No's 1 and 2. Install the lower shielded cable brackets of -8 models under the crankcase cover retaining nuts in front of the magnetos. Install the two lower cable brackets of Eisemann LA-4 shielded systems on -12 and -16 models under the lower of two crankcase cover retaining nuts in front of each magneto, and install the loose, unattached bracket under the lower starter retaining nut. Bendix shielded cable assemblies for -12, -14, -16, and O-200 models have a twisted cable bracket on each pair of upper and lower ignition cables. These are installed under the two crankcase cover retaining nuts in front of each magneto. The brackets on the two pairs of cables for lower spark plugs of cylinders No's 1 and 3 and No's 2 and 4 are installed under the pushrod housing nuts. ; Install the upper and lower spark plugs with serviceable gaskets. Tighten all plugs to specified torque. With shielded systems, install the spark plug contact sleeves carefully, and tighten the elbow union nuts only enough to prevent the elbows from turning. Install ignition cable terminals in the magnetos as described in paragraph 10-13.

16-15. GENERATOR/ALTERNATOR

Spread a film of non-hardening gasket paste on both sides of a generator and tach drive housing gasket. Place the gasket on the crankcase cover pad. Install the generator, with the wire terminals to the left, meshing the drive gear with the camshaft gear internal teeth as the mounting flange approaches the case pad. Install three elastic stop nuts on retaining studs and tighten them securely. Insert a finger through each of two openings in the drive end frame, and attempt to oscillate the armature to check gear backlash. A noticeable backlash must exist. If none is felt, loosen the retaining nuts and shift the generator upward slightly. Tighten the nuts and recheck for backlash. If none can be obtained in this manner, it will be necessary to remove the generator and to substitute another drive gear.

16-16. TACHOMETER DRIVE HOUSING (-12, -14, -16 and O-200 MODELS)

Insert a strip of fiber to completely fill the tachometer drive shaft slot and project beyond the rear end of the shaft. The surface of the strip must be smooth to protect the housing oil seal lip. Make sure that the oil seal is installed in the tachometer drive housing with the lip outward. Work the seal lip over the shaft end, and push the housing over the case studs onto the gasket. Install the three elastic stop nuts, and tighten them evenly. Remove the strip from the tachometer drive shaft slot, and install a shipping cover.

16-17. STARTER

Work non-hardening gasket paste into both surfaces of a starter' gasket, and install it on the crankcase cover pad. Lubricate the starter pinion and intermediate gear. Hold the starter assembly in position to align the clutch bore with the crankcase pivot, and push the clutch over the pivot, holding the assembly in line as it approaches and seats on its pad. Place two lockwashers and plain washers on the upper through bolts, and install them through the crankcase rear flange holes. Align the starter bolt holes and screw in the two bolts. Install plain washers, lockwashers and hex nuts on the three lower retaining studs on all model engines. Tighten the nuts and bolts evenly.

SECTION XVII

TESTING AFTER OVERHAUL

17-1. TESTING EQUIPMENT

17-2. TEST STAND

After each major overhaul, engine performance should be tested and new parts run in while the engine is mounted on a rigid test stand, preferably enclosed in a cell of such a design that cooling air recirculation will be held to a minimum. The engine stand should be constructed in such a way as to permit accessibility to all engine line and instrument connections and to permit frequent inspection of all points of possible leakage. All tubes, wires, rods and cables used to connect instruments and controls to the engine should be well supported, yet of sufficient flexibility to permit them to be moved out of the way during installation and removal of the engine.

- a. The aircraft can be considered a suitable test stand for running-in overhauled engines contingent on the following conditions:
 1. Install engine cowling.
 2. Each cylinder must be equipped with a temperature sensing device to monitor the head temperature.
 3. The flight propeller may be used contingent on careful observation of cylinder temperatures. Head the aircraft into the wind for this test.

17-3. INSTRUMENTS

In order to obtain a satisfactory report of engine performance, permanent instrument and control board should be installed in a separate enclosure, and it should be as free as possible from vibration. Instruments should be of the most rugged construction available, and they should be checked periodically to assure continuous accuracy. The following instruments will be needed to indicate engine operating conditions.

- a. Tachometer (mechanically driven) (See Tables XIV and XV).
- b. Cylinder Head Temperature Gauge.

- c. Oil Temperature Gauge.
- d. Oil Pressure Gauge.
- e. Fuel Flow Meter (or accurate means of weighing the supply).
- f. Fuel Pressure Gauge, 10 p.s.i., capacity (for carburetor engines equipped with fuel pumps).

17-4. TEST CLUB

Manufacturers of wood propellers supply wood test clubs of various sizes. A club of this type should be used for all engine testing. Flight propellers do not direct cooling air over the cylinders. For the full range of C series engines, three diameters of test club are required to absorb 75, 85 and 90 horsepower at 2275, 2575 and 2475 R.P.M., respectively. O-200 engines will require only one test club which will absorb 100 horsepower at 2750 R.P.M. Two test clubs of each size will be required to fit the two types of crankshafts of the C series engines. For tapered shafts, the clubs should be fitted with hub assemblies, as listed in the parts catalog. After installation of the hub, the club must be balanced statically. For flange type crankshafts, the test club bolt holes must be counterbored at the rear ends to fit over crankshaft flange bushings.

17-5. ENGINE TEST AFTER OVERHAUL

- a. After a partial or complete disassembly and repair of an engine, the engine will be tested in accordance with Tables XXI and XXII.
- b. Extend the second period of each test schedule, if necessary, to raise the oil temperature to the desired minimum in Table XXI.
- c. Take instrument readings at the beginning, in the middle, and at the end of the full throttle period. Take one reading during each of the other periods as soon as conditions have stabilized.

- d. After completion of oil consumption test run, make one check on performance of each magneto alone at the R.P .M. specified in Table XXI prior to cool down period.

NOTE

If tests must be conducted in extremely cold weather, it may be necessary to cover the oil sump with an oil-proof lagging.

NOTE

The following procedures should be followed to insure that adequate lubrication is being provided to newly installed components and that the piston ring seating will occur as soon as possible.

- e. Servicing and Pre-starting Procedures.

- 1. Service the lubricating system with mineral oil (MIL-C-6529 Type II.)

- e. Servicing and Pre-starting Procedures.

- 1. Service the lubricating system with mineral oil (MIL-C-6529 Type II.) of the appropriate grade depending on ambient temperature.
- 2. Rotate the propeller by hand through several cycles with the spark plugs removed.
- 3. Pre-oil the lubrication system using an external pre-oiling pressure system.
- 4. Install the spark plugs and ignition harness.

- f. Service and pre-starting procedures.

- 1. Service the lubricating system with mineral oil (MIL-C-6529 Type II) of the appropriate grade depending on ambient temperature.
- 2. Rotate the propeller by hand through several cycles with the spark plugs removed.

- 3. Pre-oil the lubrication system using an external pre-oiling pressure system.
- 4. Install the spark plugs and ignition harness.

- g. Engine starting and ground operation.

- 1. Assure that all engine and cylinder baffling is properly installed and in good condition.
- 2. Start the engine and assure that oil pressure rises to within the specified limits within 30 seconds.
- 3. Operate the engine at 750 RPM for one minute, gradually increasing toward 1000 RPM in three minutes. Check the magneto circuit for grounding prior to a normal shut-down. Allow the engine to cool adequately and then make a visual inspection for any irregularities.

- 4. Start the engine again and operate it at 750 RPM gradually increasing to 1500 RPM over a period of four minutes. If the engine is equipped with a controllable pitch propeller, cycle the propeller allowing only a 100 RPM drop. Return to the idle range and make adjustments to the idle mixture and RPM as required on carburetor engines and to the low unmetered fuel pressure, idle RPM and mixture on fuel injected engines. Position the throttle to 1200 RPM to smooth the engine. Then do an idle mixture check. Refer to the appropriate service information for these fuel system adjustments. Run engine up to full power for a period not to exceed 10 seconds. Visually inspect and correct any discrepancies. Check the oil quantity. Cowl the engine in preparation for test flight.

- h. Test Flight.

- 1. Ambient air and engine operation temperatures are of major concern during this test flight. Do a normal pre-flight run-up in accordance with the aircraft flight

manual. Conduct a normal take-off with full power and monitor the fuel flow, RPM, oil pressure, cylinder head temperatures and oil temperatures. Reduce to climb power in accordance with the flight manual and maintain a shallow climb attitude to gain optimum airspeed and cooling. Rich mixture for all operations except lean for field elevation where applicable and lean to maintain smoothness during climb in accordance with airframe manufacturers operating instructions.

2. Level flight cruise should be at 75% power with best power or richer mixture for the first hour of operation. The second hour power settings should alternate between 65% and 75% power with the appropriate

best power mixture settings. Engine controls or aircraft attitude should be adjusted as required to maintain engine instrumentation within specifications.

3. The descent should be made at low cruise power settings, with careful monitoring of engine pressures and temperatures. Avoid long descents with cruise RPM and manifold pressure below 18" hg.; if necessary decrease the RPM sufficiently to maintain manifold pressure.
4. Any discrepancies detected during test flight or any final adjustments necessary should now be made. The engine can be operated in normal service in accordance with the aircraft flight manual.

TABLE XXI TEST OPERATING LIMITS

| Feature | Value | | | |
|-------------------------------------|--------------------------|--------------------------|--------------------------|--------------------------|
| | C75 | C85 | C90 | O-200 |
| Full throttle speed (RPM) | 2275-2325 | 2575-2625 | 2475-2525 | 2750-2800 |
| Fuel Consumption (at full throttle) | 38.5-41.5 lbs/hr | 42.5-45.5 lbs/hr | **46-49 lbs/hr | 51-55 lbs/hr |
| Oil Viscosity Above 40°F. | S.A.E. 40 | S.A.E. 40 | S.A.E. 40 | S.A.E. 40 |
| Below 40° F. | 20 or 10 W 30 | 20 or 10 W 30 | 20 or 10 W 30 | 20 or 10 W 30 |
| Oil consumption (maximum) | 0.75 lbs/hr | 0.75 lbs/hr | 0.75 lbs/hr | 0.80 lbs/hr |
| Fuel Rating (octane) | 80/87 | 80/87 | 80/87 | 80/87 |
| Idling Speed (RPM) | 475-525 | 475-525 | 475-525 | 475-525 |
| Manifold Vacuum at Full Throttle | 0.5-1.3 in. Hg. | 0.5-1.4 in. Hg. | 0.901.4 in. Hg. | 0.5-2 in. Hg. |
| Manifold Vacuum at Idling Speed | 17 in. Hg. | 17 in. Hg. | #17.5 in. Hg. | 17.0-18.5 in. Hg. |
| Magneto Drop at Full Throttle (RPM) | 75 | 75 | †100 | †100 |
| *Crankcase pressure (maximum) | 1.0 in. H ₂ O | 1.0 in. H ₂ O | 1.0 in. H ₂ O | 1.0 in. H ₂ O |
| Cylinder Head Temp. (maximum) | 525° F. | 540° F. | 525° F. | 525° F. |
| Oil Temperature (desired) | 150°F. -200°F. | 150°F. -200°F. | 150°F. -200°F. | 150°F. -200°F. |
| Oil Temperature (maximum) | 225° F. | 225° F. | 225° F. | 225° F. |
| Oil Pressure (at full throttle) | 30-45 psi | 30-45 psi | 30-60 psi | 30-60 psi |
| Oil Pressure (at idle speed) | 10 | 10 | 10 | 10 |

* A sudden increase in in crankcase pressure and rapid fluctuation of manometer usually indicated sticking of rings. Before removing cylinders, check, crankcase breather and manometer.

** 47-50 lbs/hr at 2625-2675 RPM; 42-46 lbs/hr at 2475-2525 RPM with No. 391090-1 or with Marvel 10-4457 carburetors installed.

Minimum with camshaft No. 531075 installed.

† At 1800 RPM. (Let temperature settle out before taking magneto drop.)

TABLE XXII TEST SCHEDULE

| Period | Time (Minutes) | RPM | | | |
|----------------------------------------------------------------------------|----------------|----------------------------------|----------------------------------|----------------------------------|----------------------------------|
| | | C75 | C80 | C90 | O-200 |
| 1 | 15 | Warm up 900-2000 | Warm up 900-2000 | Warm up 1200-2200 | Warm up 1200-2200 |
| 2 | 10 | 2000 | 2300 | 2200 | 2400 |
| 3 | | 500±25 Idle Cooling Period | 500±25 Idle Cooling Period | 500±25 Idle Cooling Period | 500±25 Idle Cooling Period |
| Stop engine, drain oil, weigh oil in for oil consumption determination. | | | | | |
| START OIL CONSUMPTION DETERMINATION | | | | | |
| 1 | 5 | Warm up To 2000 | Warm up To 2300 | Warm up To 2200 | Warm up To 2400 |
| 2 | 10 | 2000 | 2300 | 2200 | 2400 |
| 3 | 10 | 2100 | 2400 | 2300 | 2500 |
| 4 | 5 | 2200 | 2500 | 2400 | 2600 |
| 5 | 5 | 2275-2325 | 2575-2625 | 2475-2525 | 2750-2800 |
| | | Full Throttle Check Magnetos | Full Throttle Check Magnetos | Full Throttle Check Magnetos | Full Throttle Check Magnetos |
| 6 | 5 | 500±25 Idle Cooling Period | 500±25 Idle Cooling Period | 500±25 Idle Cooling Period | 500±25 Idle Cooling Period |

Stop engine, drain oil, weigh and record engine oil consumption.

Magneto drop to be taken after completion of oil consumption run.

Oil consumption at rate of .35 lbs / ½ hr.
 Maximum acceptable rate for C75 and C85.
 Oil consumption .37 lbs / ½ hr. minimum
 Acceptable for the C90 and .39 lbs / ½ hr.
 Maximum acceptable for the O-200 .

Clear spark plugs by operating with both magnetos on for a few seconds between checks.

NOTE

The maximum cylinder head temperature and the maximum allowable oil temperature must not be exceeded at any time during the test.

17-6. PRESERVATION

If the engine is not to be installed in an aircraft and placed into service immediately, the last 15 minutes of operation should be used to circulate a corrosion-preventive oil mixture (suitable for light operation). This will be an additional period, since the engine must be stopped to change oil. Install dehydrator plugs in the spark plug holes which are in the top position when the engine is mounted in the shipping base. Seal all other openings leading to the interior of the engine with shipping covers, suitable plugs or non-hydrosopic tape.

17-7. FUEL AND LUBRICATING OIL

For testing, the fuel used for each model must have an octane rating at least equal to that specified for the model in Table XXI. Lubricating oil supplied to the engine during the test run should be of a viscosity grade also recommended in Table XVIII for range of operating temperatures obtained.

TABLE XXIII OIL SUMP CAPACITY

| Model | Capacity (Quarts) |
|-------|-------------------|
| C75 | 4 |
| C85 | 4.5 |
| C90 | 4.8 |
| O-200 | 6 |

17-8. TESTING ENGINES INSTALLED IN AIRCRAFT

Due to the inadequate air flow obtainable for engine cylinder and oil cooling when an engine is installed in an aircraft, it is recommended that no testing or running in of new parts be performed in this manner. If it becomes necessary to run-in an overhauled engine in the aircraft a wood test club should be used for ground operation. The cowling should not be installed, and the aircraft should be headed into the wind to provide the best possible cooling. A cylinder head temperature gauge must be installed, and a constant check must be made of cylinder head and oil temperatures. The maximum cylinder head temperature for the engine as specified in Table VI must never be exceeded and the engine shut down frequently enough during the test to assure this. After an hour of running has been accumulated, the flight propeller and cowling should be installed and the test completed in flight without "mushing".

17-9. INSPECTION

After completion of the test run, inspect the following features:

- a. Remove oil screen, and inspect for metal particles.
- b. Remove oil gauge, and check oil quantity and quality.
- c. Remove all spark plugs, and measure electrode gaps. Readjust if necessary, and clean any fouled plugs before reinstalling.
- d. Using a flashlight for illumination, inspect all cylinder bores for scoring while the propeller is turning slowly.
- e. Replace spark plugs, and test for uniform cylinder compression by turning the propeller, or use a cylinder pressure gauge before installing the upper set of spark plugs. Actual pressure values will depend on several variables, but they should be uniform among cylinders.

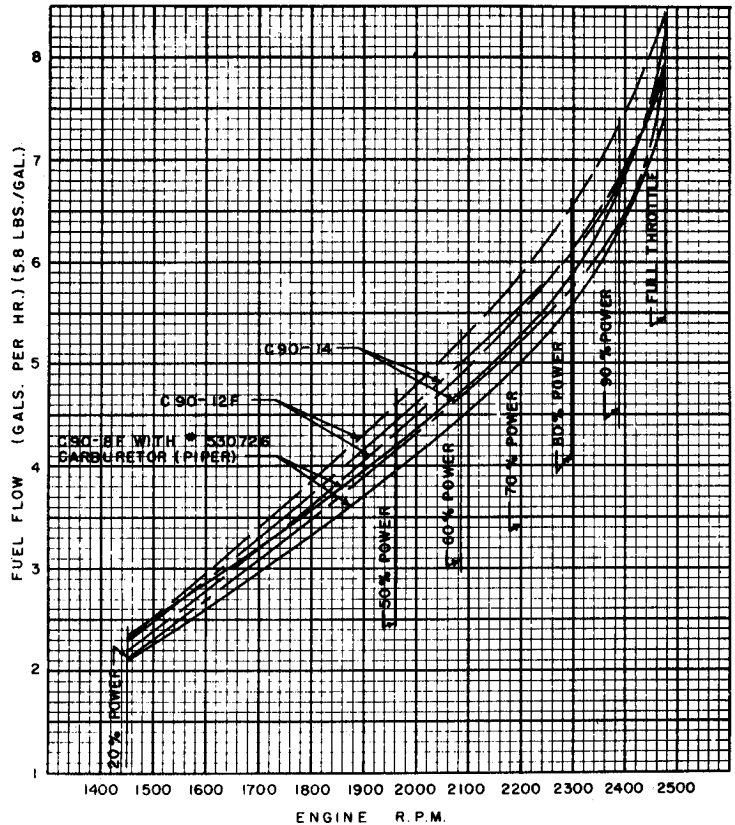

Figure 41. Fuel Flow Limits vs. R.P.M. at Propeller Load, Model C90.

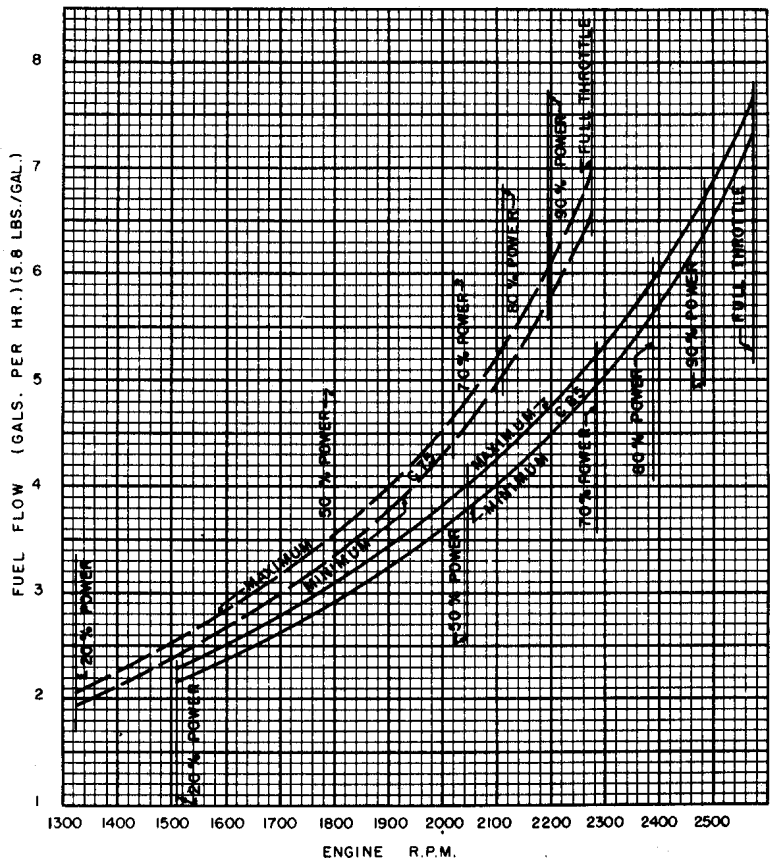

Figure 42. Fuel Flow Limits vs. R.P.M. at Propeller Load, Models C75 and C85.

FUEL FLOW (GALS. PER HR.) (5.8 LBS./GAL.)

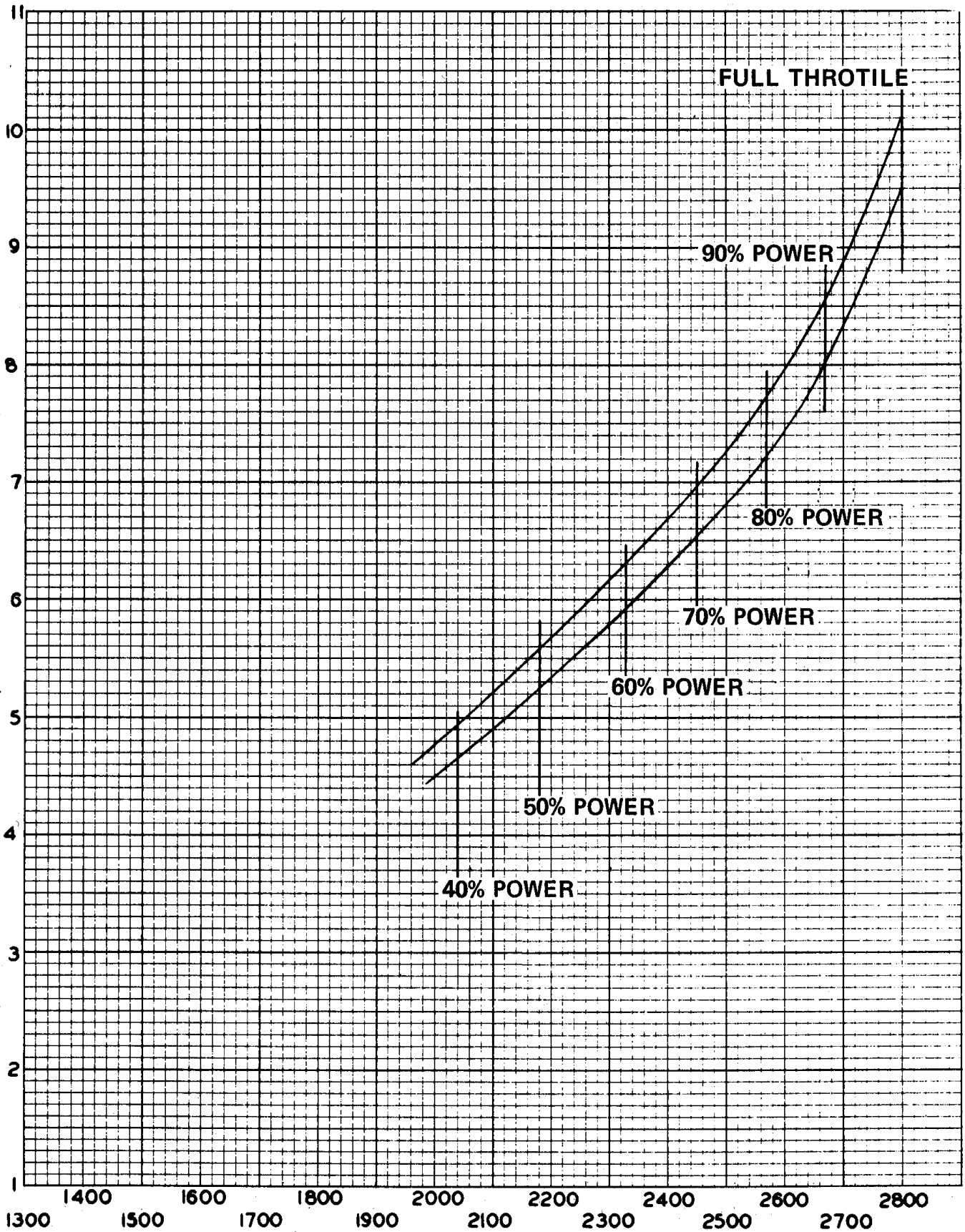

Figure 43. Fuel Flow Limits vs. R.P.M. at Propeller Load, Model O-200.

SECTION XVIII

TABLE OF LIMITS

| Ref. No. | Chart No. | Description | New Parts | | Service Maximum |
|----------|-----------|---------------------------------------------------------------------------------|-----------|-----------|-----------------|
| | | | Minimum | Maximum | |
| | | C75, C85 PISTON | | | |
| 1 | 1 | Top Land in Cylinder Bore. Dia: | .034L | .038L | |
| 2 | 1 | 2nd, 3rd & 4th Lands in Cylinder Bore. Dia: | .030L | .034L | |
| 3 | 1 | Top of Skirt in Cylinder Bore. Dia: | .009L | .013L | .016L |
| 4 | 1 | Bottom of Skirt in Cylinder Bore. Dia: | .007L | .010L | .013L |
| | | C90, O-200 PISTON | | | |
| 5 | 1 | Top Land in Cylinder Bore. Dia: | .038L | .042L | |
| 6 | 1 | 2nd & 3rd Land in Cylinder Bore. Dia: | .034L | .038L | |
| 7 | 1 | Top of Skirt in Cylinder Bore. Dia: | .012L | .015L | .018L |
| 8 | 1 | Bottom of Skirt (above 4th groove) in Cylinder Bore. Dia: | .009L | .012L | .015L |
| 9 | | Deleted | | | |
| | | PISTON RINGS | | | |
| 10 | 1 | Top Piston Ring in Groove (C75 & C85) Side Clear: | .005L | .0065L | .009L |
| | | Top Piston Ring in Groove (C90 & O-200) Side Clear: | .006L | .008L | .010L |
| 11 | 1 | 2nd & 3rd Piston Rings in Groove (C75 & C85) Side Clear: | .003L | .005L | .007L |
| | | 2nd Piston Ring in Groove (C90 & O-200) Side Clear: | .0045L | .0065L | .009L |
| | | 3rd Ring in Groove (C90 & O-200) Side Clear: | .005L | .007L | .009L |
| 12 | 1 | Oil Control Ring in Groove. Side Clear: | .002L | .004L | .006L |
| | | Top Ring in Groove. Side Clear: | .006 | .008 | .010 * |
| | | 2nd Ring in Groove. Side Clear: | .0045 | .0065 | .009 * |
| | | 3rd Ring in Groove. Side Clear: | .0025 | .0045 | .006 * |
| | | Oil control Ring in Groove. Side Clear: | .0020 | .0040 | .006 * |
| 13 | 1 | Top Ring in Cylinder (C75 & C85). Gap: | .018 | .035 | .040 # |
| | | Top Ring in Cylinder (C90 & O-200). Gap: | .021 | .040 | .045 # |
| | | 2nd Ring in Cylinder (C75, C85, C90, O-200) Gap: | .013 | .030 | .035 # |
| | | 3rd Ring in Cylinder (C75, C85, C90 & O-200) Gap: | .013 | .030 | .035 # |
| | | 4th Ring in Cylinder (C75 & C85) Gap: | .013 | .025 | .035 # |
| | | 4th Ring in Cylinder (C90 & O-200) Gap: | .013 | .030 | .035 # |
| 14 | 1 | Compression Ring Tension (closed to specified gap) : | 9.0 lbs. | 12.0 lbs. | 8.0 lbs. |
| 15 | 1 | Oil Control Ring Tension (closed to specified gap) : | 11.0 lbs. | 15.0 lbs. | 10.0 lbs. |
| | | PISTON PINS | | | |
| 16 | 1 | Piston Pin and Plugs No. 530830 in Cylinder. End Clear: | .010 | .032 | .080 |
| 17 | 1 | Piston Pin in Piston (Pistons 40327 & 530348) Dia: | .0001L | .0007L | .0015L |
| 18 | 1 | Piston Pin in Connecting Rod Bushing (Rods A35160-A2 & 530184-A1) Dia: | .0014L | .0021L | .004L |
| 19 | | Deleted | | | |
| | | CONNECTING ROD | | | |
| 20 | 1 | Conn. Rods 530184A1 & A35160A2 on Crankpin End Clear: | .006L | .010L | .016L |
| 21 | 1 | Conn. Rod Bearing No. 35897 on Crankpin Dia: | .005L | .003L | .006L |
| | | Conn. Rod Bushing in Conn. Rod. Dia: | .002T | .0045T | -- |

* Chrome Plate

If necessary, use .005" oversize rings to maintain specified limits in cylinder bore to service limits.

| Ref. No. | Chart No. | Description | New Parts | | Service Maximum |
|--------------------------|-----------|-------------------------------------------------------------------------------------------------------------------|----------------|-----------------|-------------------|
| | | | Minimum | Maximum | |
| | | Conn. Rod Bushing Bore Bushings Dia: | .9230 | .9235 | ---- |
| 22 | 1 | Conn. Rod Bearings & Bearings (out-of-round and taper) | .0000 | .0005 | .0005 |
| 23 | 1 | Conn. Rod Bearings & Bushings Twist or Convergence per in. of Length: Bolt in Conn. Rod. Dia: | .000 .0005L | .001 .0023L | .001 ---- |
| CRANKSHAFT | | | | | |
| 24 | 2 | Crankshaft to Thrust Washers End Clear: | .004 | .015 | .004 |
| 25 | 2 | Crankshaft in Front Main Bearing Dia: | .0005 | .0035L | .006 L |
| 26 | 2 | Crankshaft in Center and Rear Bearings Dia: | .0005 | .0035L | .006 L |
| 27 | 2 | Crankpins Dia: | 1.9360 | 1.9370 | 1.934 † |
| 27 | 2 | Crankpins Out-of-round: | .000 | .0005 | .001 † |
| 28 | 2 | Run-out at Center Journal (shaft supported at front and rear journal) (Full Indicator Reading): | .000 | .010 | .010 |
| | | Run-out at Front End of Taper (shaft supported at front and rear journals) (Full Indicator Reading): | .000 | .006 | .006 |
| 29 | 2 | Run-out on Face of Flange, Near Edge (shaft supported at front and rear journals) (Full Indicator Reading): | .000 | .005 | .006 |
| 30 | 2 | Main Journals Dia: Main Journals. Out-of-round: | 1.8720 .000 | 1.8730 .0005 | 1.870 † .001 † |
| CAMSHAFT | | | | | |
| 31 | 2 | Journals in Crankcase Bearings Dia: | .001 L | .003 L | .005 L |
| 32 | 2 | Rear Journal Flange to Crankcase End Clear: | .004 | .008 | .012 |
| 33 | 1 | Valve Lifter in Crankcase Guide Dia: | .0005 L | .002 L | .0035 L |
| 34 | 2 | Camshaft Journals Dia: | 1.3725 | 1.3735 | --- |
| | | Cam Gear Pilot Dia: | 2.8740 | 2.8750 | --- |
| 35 | 2 | Vacuum Pump Gear on Camshaft Pilot (O-200) Dia: | .0000 | .002 L | --- |
| ROCKERSHAFT | | | | | |
| 36 | 1 | Rocker Shaft in Rocker Bushing Dia: | .001 L | .0025 L | .004 L |
| 37 | 1 | Rocker Shaft in Cylinder Head Bosses Dia: | .0002 L | .0017 L | .002 L ** |
| VALVES AND GUIDES | | | | | |
| 38 | 1 | Exhaust Valve in Guide (C75, C85, C90) Dia: | .0035L | .0055L | .008 L |
| | | Exhaust Valve in Guide (O-200) Dia: | .0030L | .0045L | .008 L |
| 39 | 1 | Intake Valve in Guide Dia: | .001 L | .003 L | .005 L |
| 40 | 1 | Valve Guide (Int. & Exh.) in Cylinder Head Dia: | .001 T | .003 T | --- |
| 41 | 1 | Valve Face (Exh.) (to stem axis) Angle: | 45° 45' | 46° 15' | --- |
| | | Valve Face (Int.) (to stem axis) Angle: | 60° 45' | 61° 15' | --- |
| | | Exhaust Valve Stem (PIN 3921) Dia: | .4325 | .4335 | --- |
| | | Exhaust Valve Stem (PIN 629404) Dia: | .4335 | .4340 | --- |
| | | Intake Valve Stem Dia: | .3412 | .3422 | --- |
| | | Exhaust Valve Face Width: | .1536 | .1602 | --- |
| | | Intake Valve Face Width: | .1336 | .1478 | --- |

* If Camshafts bearings exceed this limit line ream and install .020 inch O.S. camshaft.

** Install bushings in cylinder head bosses if this limit is exceeded.

† If crankshafts are worn beyond these limits they may be repaired by grinding the crankpins and journals to 0.010" under new shaft limits and nitriding the crankshafts.

| Ref. No. | Chart No. | Description | New Parts | | Service Maximum |
|----------|-----------|---------------------------------------------------------------------------|-----------|---------|-----------------|
| | | | Minimum | Maximum | |
| 42 | 1 | VALVES AND GUIDES (Con't) | | | |
| 42 | 1 | Exhaust Valve (max. tip regrind .015)Length: | 4.056 | 4.072 | 4.041 |
| | | Intake Valve (max. tip regrind .015)Length: | 4.041 | 4.057 | 4.026 |
| | | Exhaust Valve Guide Bore Dia: | .4370 | .4380 | --- |
| | | Intake Valve Guide Bore Dia: | .3432 | .3442 | --- |
| | | CYLINDER | | | |
| 43 | 1 | Cylinder Bore (Standard) (at any point) Dia: | 4.062 | 4.064 | 4.069 †† |
| 43 | 1 | Cylinder Bore. Out-of-round | .000 | .001 | .002 †† |
| 43 | 1 | Cylinder Bore (largest dia. at bottom if any) Taper: | .000 | .001 | .002 †† |
| 44 | 1 | Cylinder Bore (reground to .015 in. O.S.) Dia: | 4.077 | 4.079 | 4.084 |
| 44 | 1 | Cylinder Bore Surface Roughness (in micro inches R.M.S.) : | 35 | 45 | 30 |
| 45 | 1 | Cylinder Barrel in Crankcase Dia: | .003 L | .012 L | --- |
| 46 | 1 | Intake Valve Insert in Cylinder Head Dia: | .0055T | .0085T | --- |
| 47 | 1 | Exhaust Valve Insert in Cylinder Head Dia: | .005 T | .008 T | --- |
| 48 | 1 | Valve Seat (to valve guide axis) Exhaust Angle: | 44° 45' | 45° 15' | --- |
| | | Valve Seat (to valve guide axis) Intake Angle: | 59° 30' | 60° 00' | --- |
| | | Exhaust Valve Seat. Width: | .0608 | .0820 | --- |
| | | Intake Valve Seat. Width: | .0828 | .1001 | --- |
| | | ROCKER ARMS | | | |
| 49 | 1 | Bushing in Rocker Arm Dia: | .002 T | .004 T | --- |
| 50 | 1 | Rocker Arm in Support Bosses Side Clear: | .004 | .011 | .016 |
| 51 | 1 | Pushrod Over-all Length : | 10.797 | 10.827 | 10.787 |
| 52 | 1 | Clearance Between Rocker Arm and Edge of Valve Spring Retainer : | .020 | | (min.) .020 |
| 53 | 1 | Valve Stem to Rocker Clearance (lifter deflated)..... : | .030 | .110 | --- |
| | | OIL PUMP | | | |
| 54 | 2 | Oil Pump Gear in Pump HousingEnd Clear: | .002 L | .005 L | .007 L |
| 55 | 2 | Oil Pump Gear in Pump Housing Dia: | .003 L | .006 L | .008 L |
| 56 | 2 | Oil Pump Gear Shafts in Accessory Case and Plate Dia: | .0015 L | .003 L | .0045 L |
| 57 | 2 | Gear on Crankshaft Pilot Dia: | .0005 T | .0015 T | --- |
| 58 | 2 | Camshaft Gear on Camshaft Pilot Dia: | .0005 T | .0015 T | --- |
| 59 | 2 | Oil Seal in Tachometer Drive Housing Dia: | .001 T | .007 T | --- |
| 60 | 2 | Magneto pilot in Accessory Case Dia: | .001 L | .005 L | --- |
| 61 | 4 | Starter pilot in Accessory Case Dia: | .0005 L | .006 L | --- |
| 62 | 4 | Generator Pilot in Accessory Case Dia: | .001 L | .005 L | --- |
| | | Oil Pump Gear Cavity. Dia: | 1.499 | 1.501 | --- |
| | | Oil Pump Gear Shaft Bore Dia: | .5620 | .5630 | --- |
| | | Oil Pump Gear Cavity Depth: | .624 | .626 | --- |
| | | Drive Hub to Generator Shaft Dia: | .0002 T | .0012 T | --- |
| | | Coupling Retainer to Hub Side Clear: | .005 T | .015 L | .020 L |
| | | Gear on Generator Sleeve Dia: | .001 L | .003 L | .005 L |

†† If limits are exceeded, regrind to .015 inch O.S. or rebarrel.

| Ref. No. | Chart No. | Description | New Parts | | Service Maximum |
|----------|-----------|----------------------------------------------------------------------|-----------|---------|-----------------|
| | | | Minimum | Maximum | |
| 63 | 2 | VACUUM PUMP Bushing in Adapter Dia: | .001 T | .004 T | --- |
| | | Bushing Bore Dia: | .8145 | .8155 | --- |
| | | Bushing Thrust Face to Pump Mounting Pad Length: | 1.113 | 1.115 | 1.111 |
| 64 | 2 | Pump Driven Gear in Adapter Assembly Dia: | .0015L | .0035L | .005L |
| 65 | 2 | Oil Seal in Adapter Dia: | .001 T | .007 T | --- |
| 66 | 2 | Adapter Pilot in Crankcase Dia: | .000 | .004 L | --- |
| | | CRANKCASE | | | |
| 67 | 4 | Starter Pinion Pivot in Crankcase Dia: | .001T | .001L | --- |
| 68 | 4 | Starter Pinion Pivot Shaft Dia: | .5595 | .5605 | .558 |
| 69 | 1 | Hydraulic Tappet Bore in Crankcase Dia: | .7187 | .7197 | --- |
| 70 | 2 | Camshaft Bearings Dia: | 1.3745 | 1.3755 | --- |
| | | Main Bearing Bore Dia: | 2.0615 | 2.0625 | --- |
| | | GEAR TEETH BACKLASH | | | |
| 71 | 3&4 | Crankshaft Gear to Camshaft Gear | .006 | .009 | .013 |
| 72 | 3 | Magneto Drive Gears to Crankshaft Gear (-8) | .0140 | .017 | .020 |
| 73 | 4 | Magneto Drive Gears to Camshaft Gear (-12, -14, -16, 0-200) | .012 | .014 | .016 |
| 74 | 4 | Starter Gear to Crankshaft Gear (-12, -14, -16, 0-200) | .029 | .043 | .050 |
| 75 | 4 | Generator Drive Gear to Camshaft (-12, -14, -16, 0-200) | .010 | .014 | .019 |
| 76 | 3&4 | Oil Pump Gears | .014 | .022 | .025 |
| 77 | 2 | Vacuum Pump Driven Gear to Driving Gear (0-200) | .002 | .006 | .010 |

SPRING PRESSURES

| Ref. No. | Chart No. | Description | Part No. | Wire Dia. | Comp. To | New Parts | | Service Limit/Lbs. |
|----------|-----------|-------------------------------------|----------|-----------|----------|-----------|------|--------------------|
| | | | | | | Min. | Max. | |
| 78 | 1 | Valve Spring (C75, C85, C90, O-200) | 24029 | .111 | 1.137 | 40 | 44 | 37 |
| 79 | 1 | Valve Spring (C75, C85, C90) | 24030 | .142 | 1.168 | 58 | 63 | 55 |
| 80 | 1 | Valve Spring (C90, O-200) | 24031 | .091 | 1.075 | 27 | 30 | 24 |
| 81 | 1 | Valve Spring (O-200) | 625958 | .148 | 1.168 | 77 | 83 | 74 |
| 82 | 3&4 | Oil Pressure Relief Spring | 631706 | .041 | 1.56 | 6.06 | 6.31 | 5.75 |

TIGHTENING TORQUES

| Ref. No. | Chart No. | Description | Thread Size | Torque | |
|----------|-----------|-------------------------------------------------------|-------------|-----------|-------------|
| | | | | In. Lbs. | Ft. Lbs. |
| T-1 | 1 | Spark Plugs..... | 18mm | 300 - 360 | 25.0 - 30.0 |
| T-2 | 2 | Plug, Oil Sump Drain..... | 5/8-18 | Oil Tight | |
| T-3 | 1 | Nuts and Cap Screws (General)..... | 1/4-28 | 90 - 110 | 7.5 - 9.2 |
| T-4 | 1 | Nut, Cylinder Base | 7/16-20 | 490 - 510 | 40.8 - 42.5 |
| T-5 | 1 | Nut, Cylinder Base | 3/8-24 | 410 - 430 | 34.2 - 35.8 |
| T-6 | 1 | Nut, Crankcase Through Stud (C75, C85, C90)..... | 7/16-20 | 400 - 450 | 33.3 - 37.5 |
| T-6 | 1 | Nut, Crankcase Through Stud (O-200)..... | 7/16-20 | 490 - 510 | 40.8 - 42.5 |
| T-7 | 1 | Nut, Crankcase Through Stud..... | 3/8-24 | 275 - 325 | 22.9 - 27.1 |
| T-8 | 4 | Nut, Generator Drive Shaft..... | 5/16-24 | 175 - 200 | 14.6 - 16.7 |
| T-9 | 2 | Screw, Gear to Crankshaft..... | 1/4-28 | 140 - 160 | 11.7 - 13.3 |
| T-10 | 2 | Screw, Gear to Camshaft..... | 1/4-28 | 140 - 160 | 11.7 - 13.3 |
| T-11 | 1 | Nut, Connecting Rod Bolt..... | 3/8-24 | 400 - 475 | 33.3 - 39.6 |
| | | Bolt, Propeller Hub | 3/8-24 | 200 - 220 | 16.7 - 18.3 |
| | | Nut, Engine Mount Bolt (-8, -12 and -16 Models) | 3/8-24 | 60 - 80 | 5.0 - 6.7 |
| | | Nut, Engine Mount Bolt (-14 and O-200 Models) | 3/8-24 | 180 - 190 | 15.0 - 15.8 |

TABLE XXIV GENERAL USE – TIGHTENING TORQUES

| Size | BOLTS, NUTS & SCREWS | | DRIVING STUDS | |
|---------|----------------------|-------------|---------------|-------------|
| | In. Lbs. | Ft. Lbs. | In. Lbs. | Ft. Lbs. |
| 8-32 | 22.0 - 30.0 | 1.9 - 2.5 | | |
| 10-32 | 36.0 - 50.0 | 3.0 - 4.2 | | |
| ¼-20 | 75.0 - 85.0 | 6.3 - 7.1 | 50.0 - 70.0 | 4.2 - 5.8 |
| ¼-28 | 90.0 - 110.0 | 7.5 - 9.2 | | |
| 5/16-18 | 155.0 - 175.0 | 13.0 - 14.6 | 100 - 150 | 8.3 - 12.5 |
| 5/16-24 | 180.0 - 220.0 | 15.0 - 18.3 | | |
| 3/8-16 | 220.0 - 260.0 | 18.3 - 21.7 | 200 - 274 | 16.6 - 22.8 |
| 3/8-24 | 275.0 - 325.0 | 22.9 - 27.1 | | |
| 7/16-14 | | | 300 - 424 | 25.0 - 35.4 |
| 7/16-20 | 400.0 - 450.0 | 33.3 - 37.5 | | |
| ½-20 | 550.0 - 600.0 | 45.8 - 50.0 | | |

NOTE

Torque loads are listed for use with oil on threads, except for studs. Stud driving torques apply when the threads are coated with Alcoa thread lube if hole is blind, or with National Oil Seal compound if hole is through to a cavity subject to oil.

If cotter pin holes must be aligned set torque wrench at low limit and tighten nut to first hole beyond this torque. However, on connecting rod nuts the torque limits must be maintained. Replace nut and repeat as required. In no case shall connecting rod nuts be torqued below low limit or over high limit.

TABLE XXV PIPE PLUGS

| Size | In. Lbs. | Ft. Lbs. |
|--------|-----------|-------------|
| 18-27 | 60 - 80 | 5.9 – 6.6 |
| 1/4-18 | 130 – 150 | 10.9 – 12.5 |
| 3/8-18 | 185 – 215 | 15.4 – 18.0 |
| 1/2-14 | 225 – 285 | 21.2 – 23.8 |
| 3/4-14 | 310 - 350 | 25.8 – 29.2 |

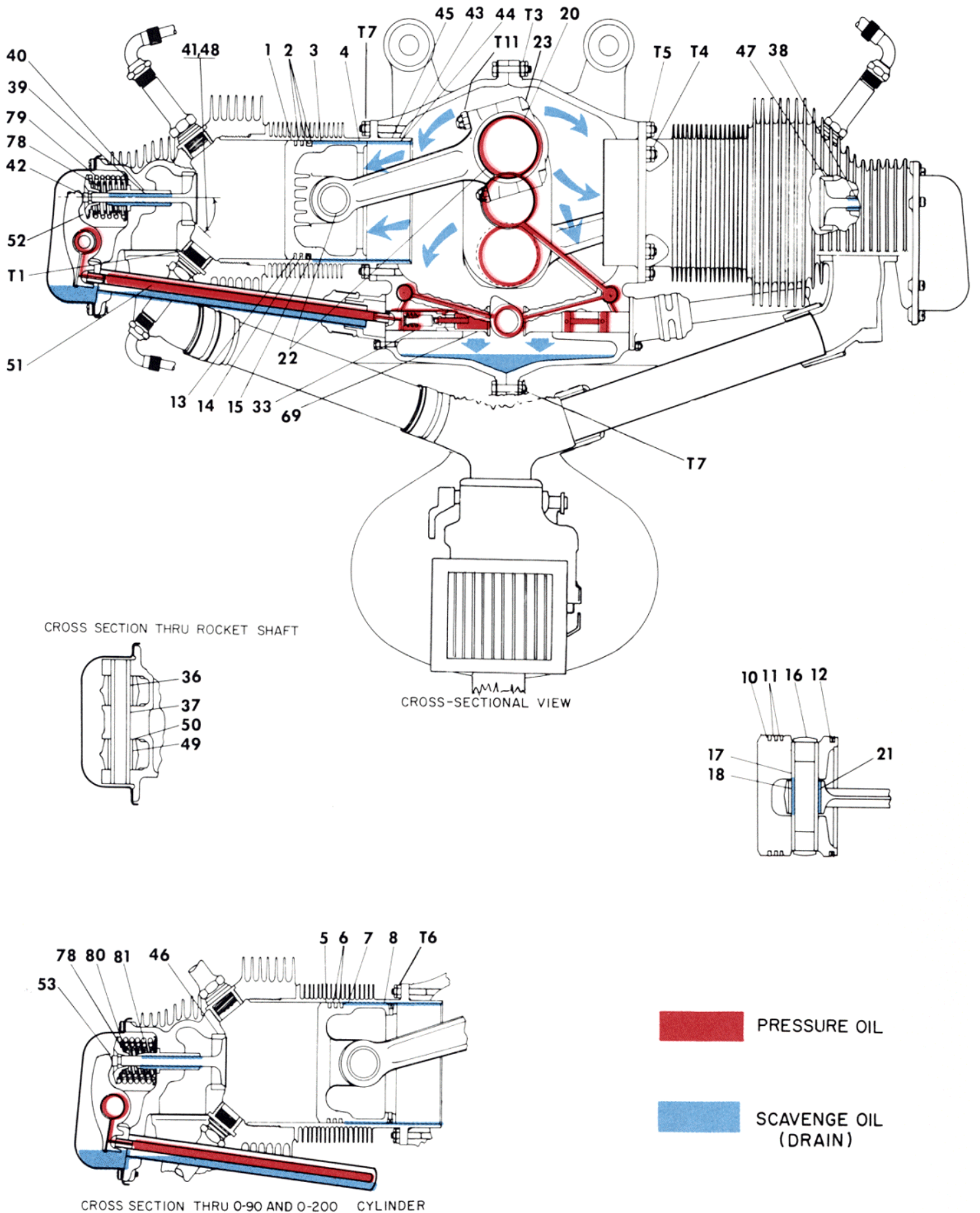

Figure 44. Limits and Lubrication Chart (Sheet 1 of 4) – Cross Section View

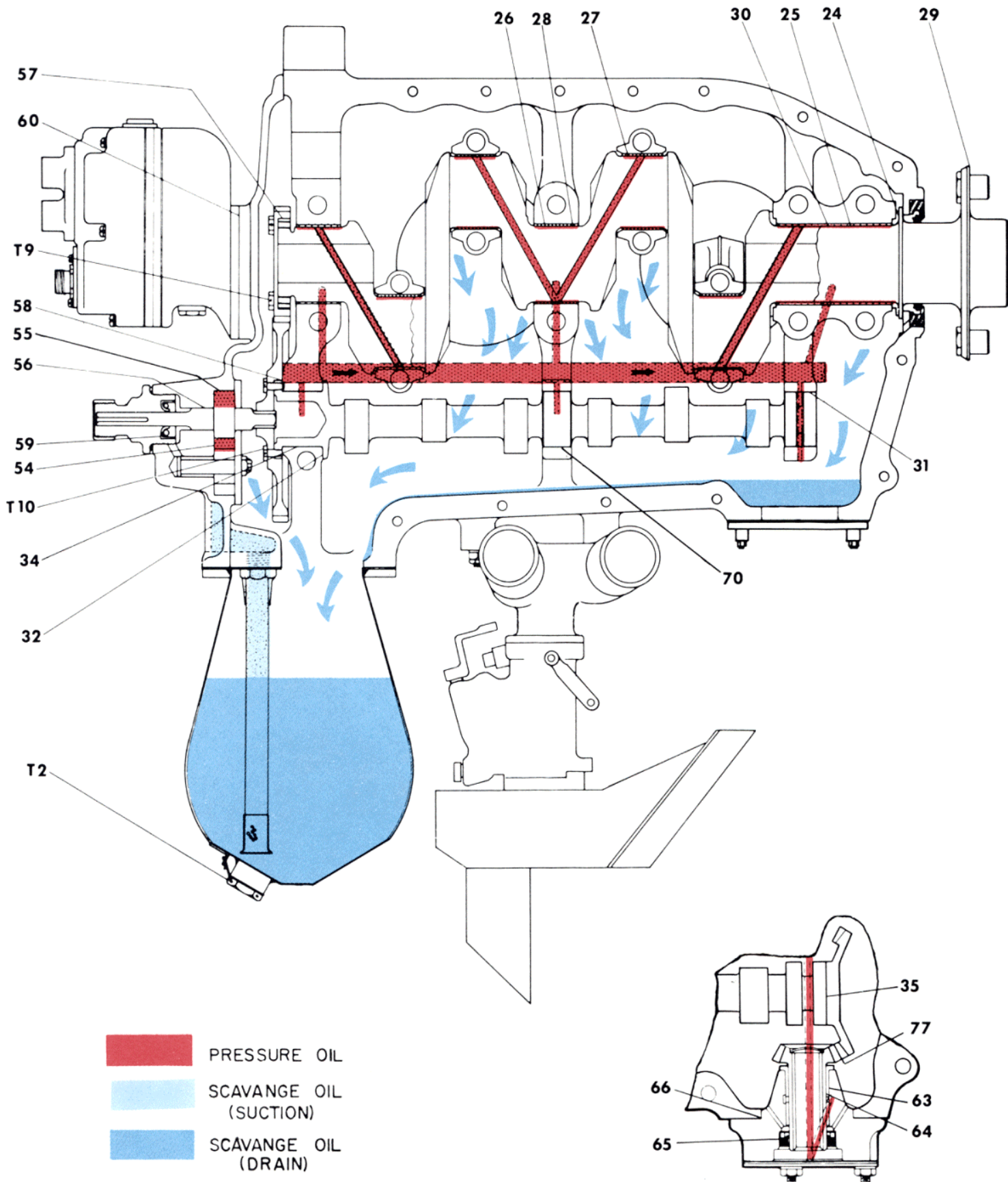
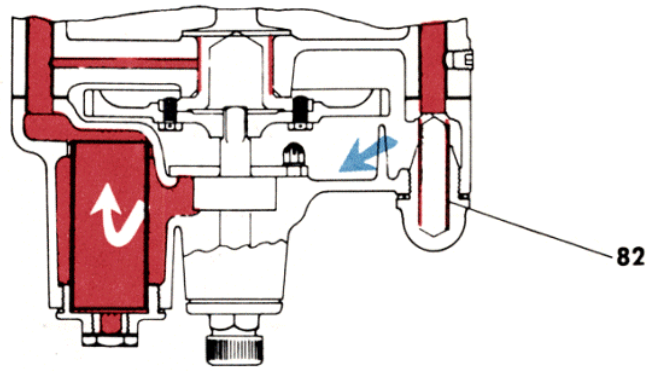
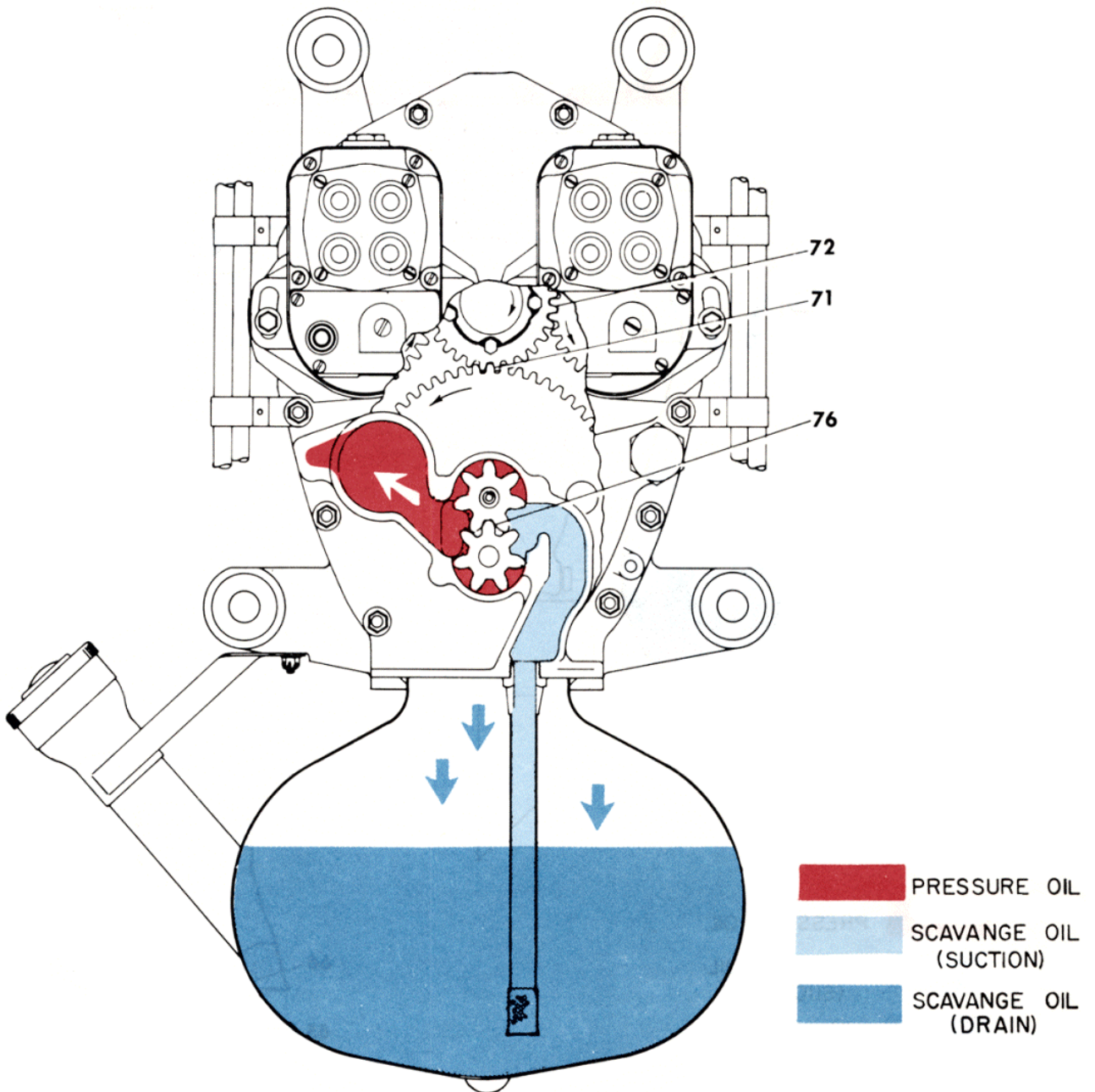

Figure 45. Limits and Lubrication Chart (Sheet 2 of 4) – Longitudinal Section View.



VIEW SHOWING PRESSURE OIL
THRU OIL SCREEN INTO OIL GALLERY
& PRESSURE RELIEF VALVE



REAR VIEW SERIES 8 ENGINE

Figure 46. Limits and Lubrication Chart (Sheet 3 of 4) – Rear View and Horizontal Section, -8 Model.

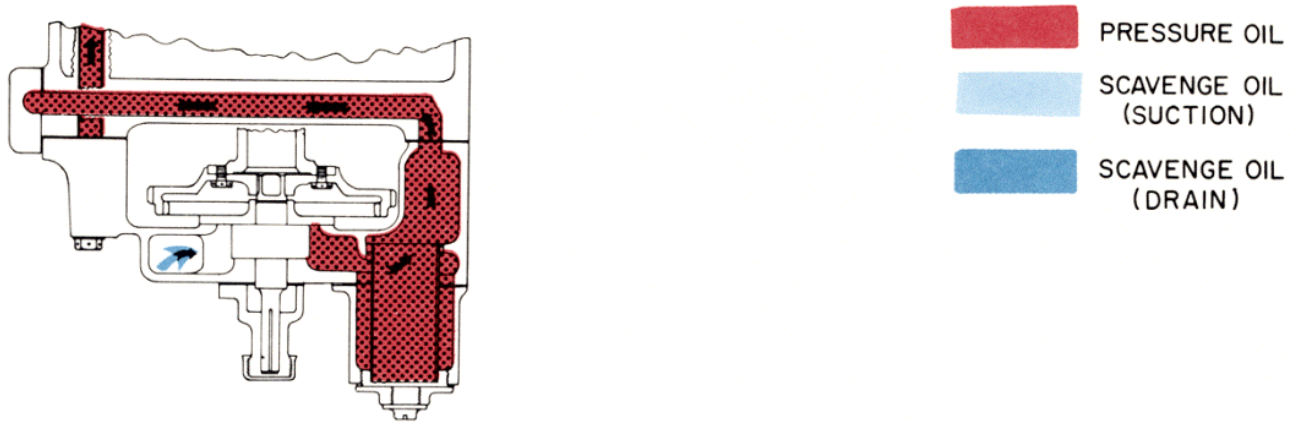

SECTION SHOWING OIL PASSAGE THRU OIL SCREEN AND OIL PASSAGE ACROSS CRANKCASE

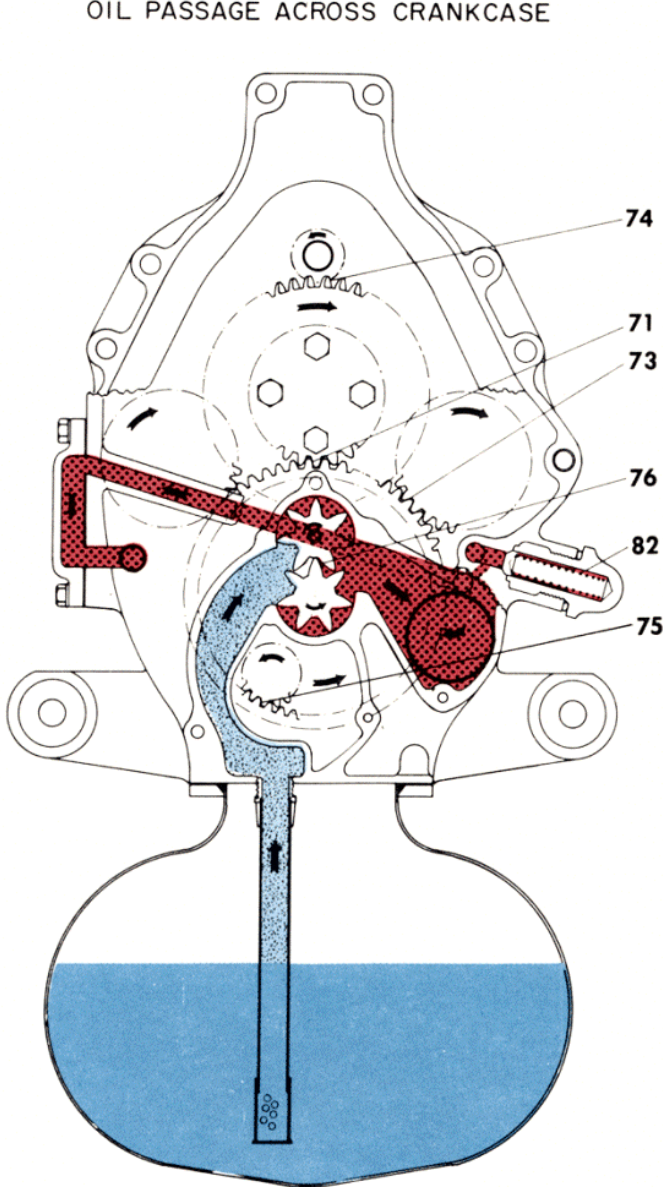

REAR VIEW (-12 ENGINE) SHOWING OIL PRESSURE RELIEF VALVE AND OIL COOLER MOUNTING PAD

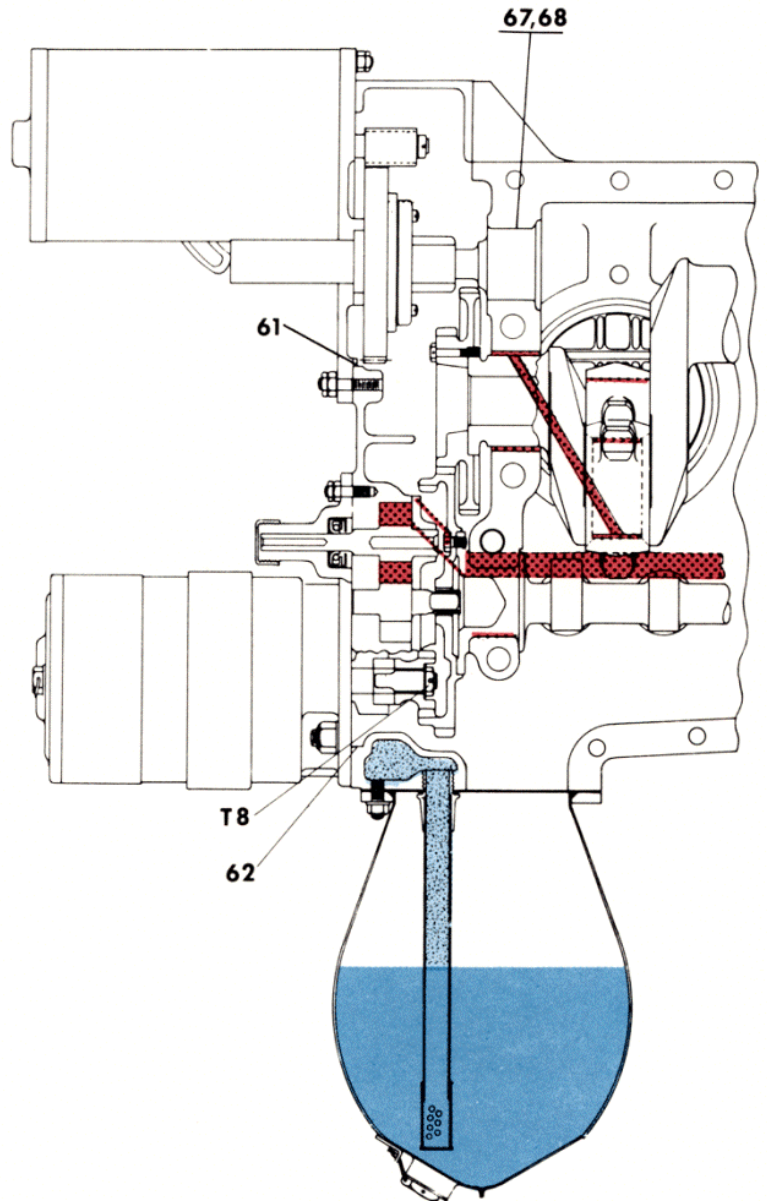

REAR PORTION OF LONGITUDINAL SECTION (-12 ENGINE)

LUBRICATION CHART (-12 ENGINE)

Figure 47. Limits and Lubrication Chart (Sheet 4 of 4) – Rear View and Sections, -12, -14, -16 and O-200 Model.