

MATERIAL: STEEL 4130 TUBE

NOTES:
 1. HEAT TREAT 200,000 PSI, THEN MAGNAFLUX
 2. USE 4130 STEEL WELDING ROD

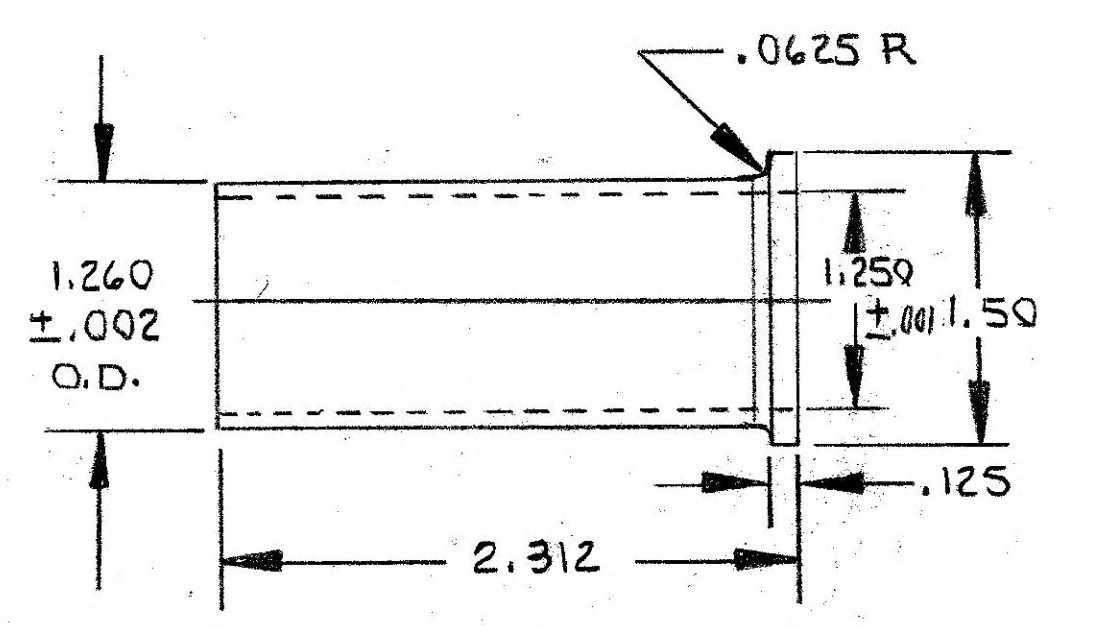

-4 BUSHING
 MAKE FROM BRONZE TUBE 1.50 X 1.00

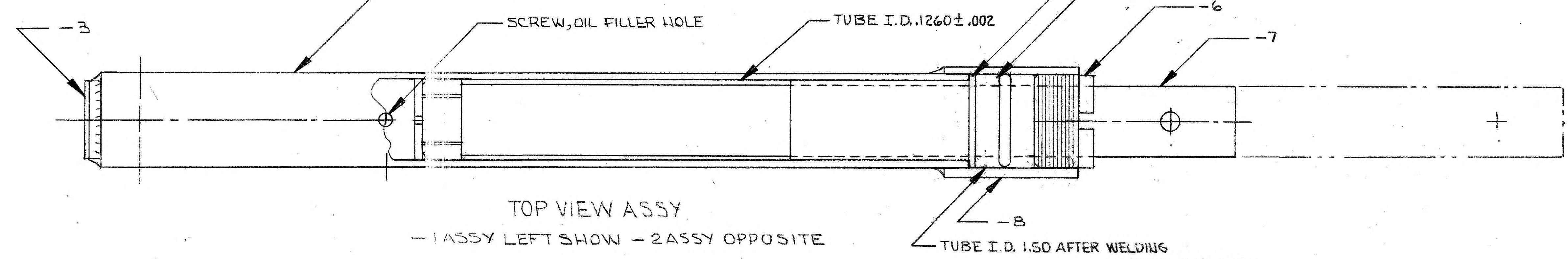
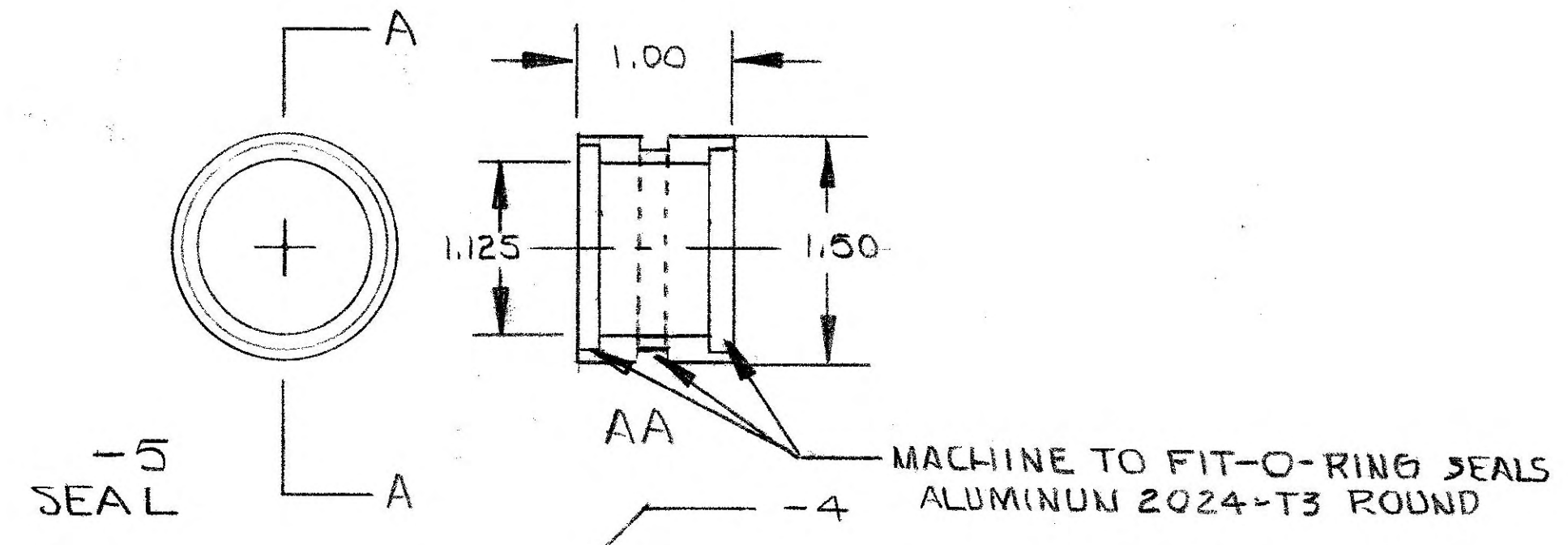
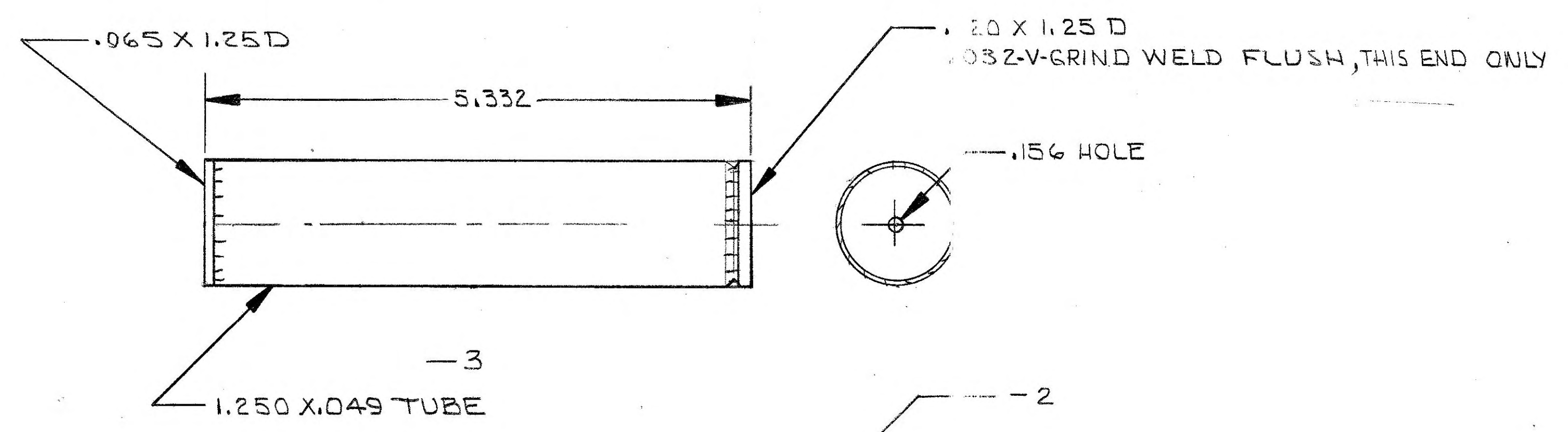
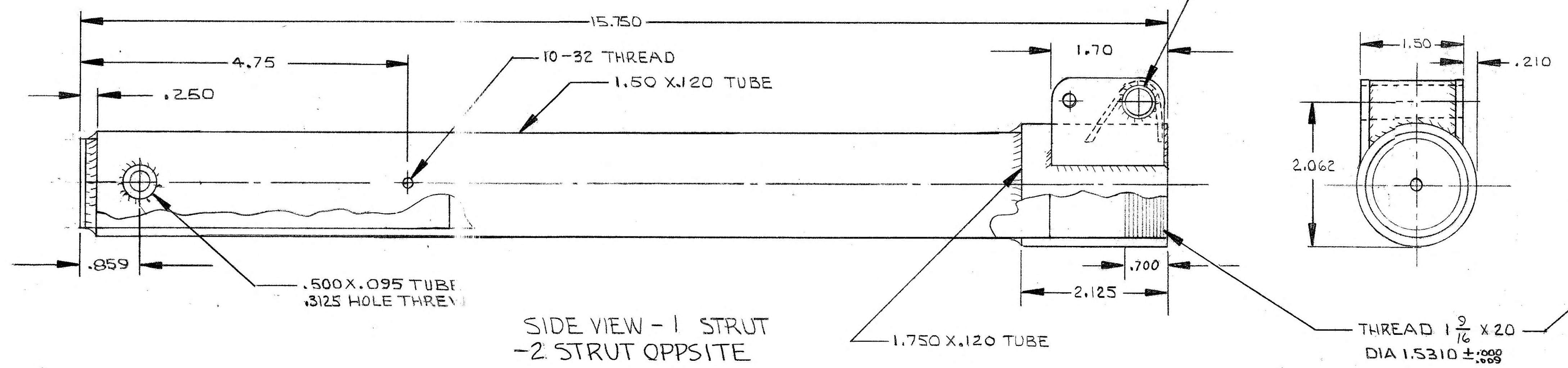

-6 NUT
 MAKE FROM BRONZE TUBE 1.625 X 1.125

SIDE VIEW - 1 STRUT
 -2 STRUT OPPOSITE

TOLERANCES UNLESS AS NOTED		REVISIONS			AERO-SYSTEMS WICHITA, KS 67212		
DECIMAL	FRACTIONAL	NO.	DATE	BY	CADET STRUT, OLEO STRUT ASSY		
±.001		1			DRAWN BY NICK FRANCE		
		2			SCALE	1/1	MATERIAL STEEL 4130
		3			CHK'D	DATE 10-5-93	DRAWING NUMBER 092
		4			TRACED	APP'D	
		5					
		6					