

DRILL HOLES TO MATCH
GEAR SUPPORT PYLON
2PL

TUBE 1.250X.095

PIVOT TUBE

MATERIAL: STEEL 4130

NOTES:

1. USE 4130 STEEL ROD TO WELD ASSY'S
2. HEAT TREAT TO 2000.000 LBS / SQ IN, ULTIMATE TENSILE STRENGTH
3. MAGNAFLUX AFTER HEAT TREAT

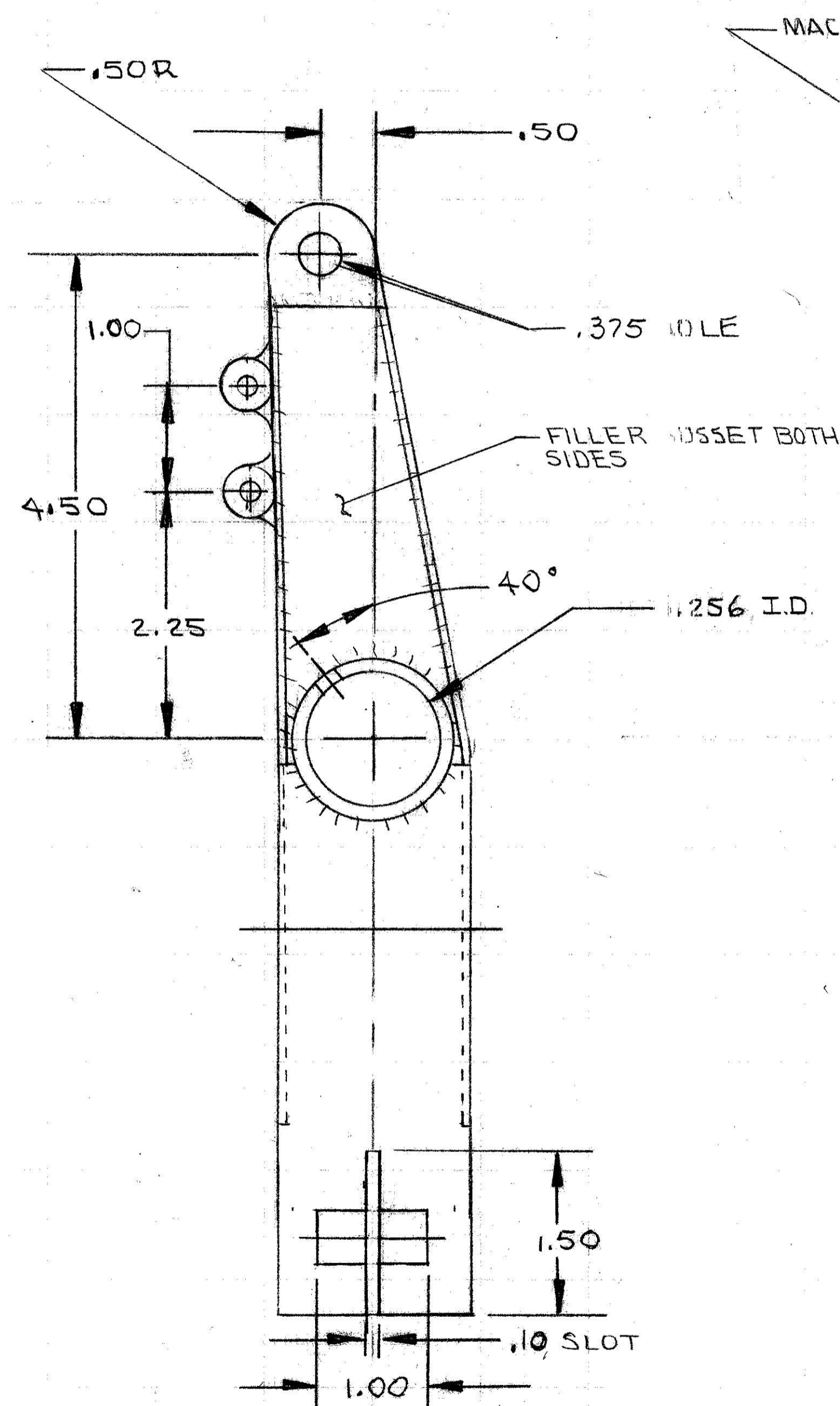

MACHINED PART

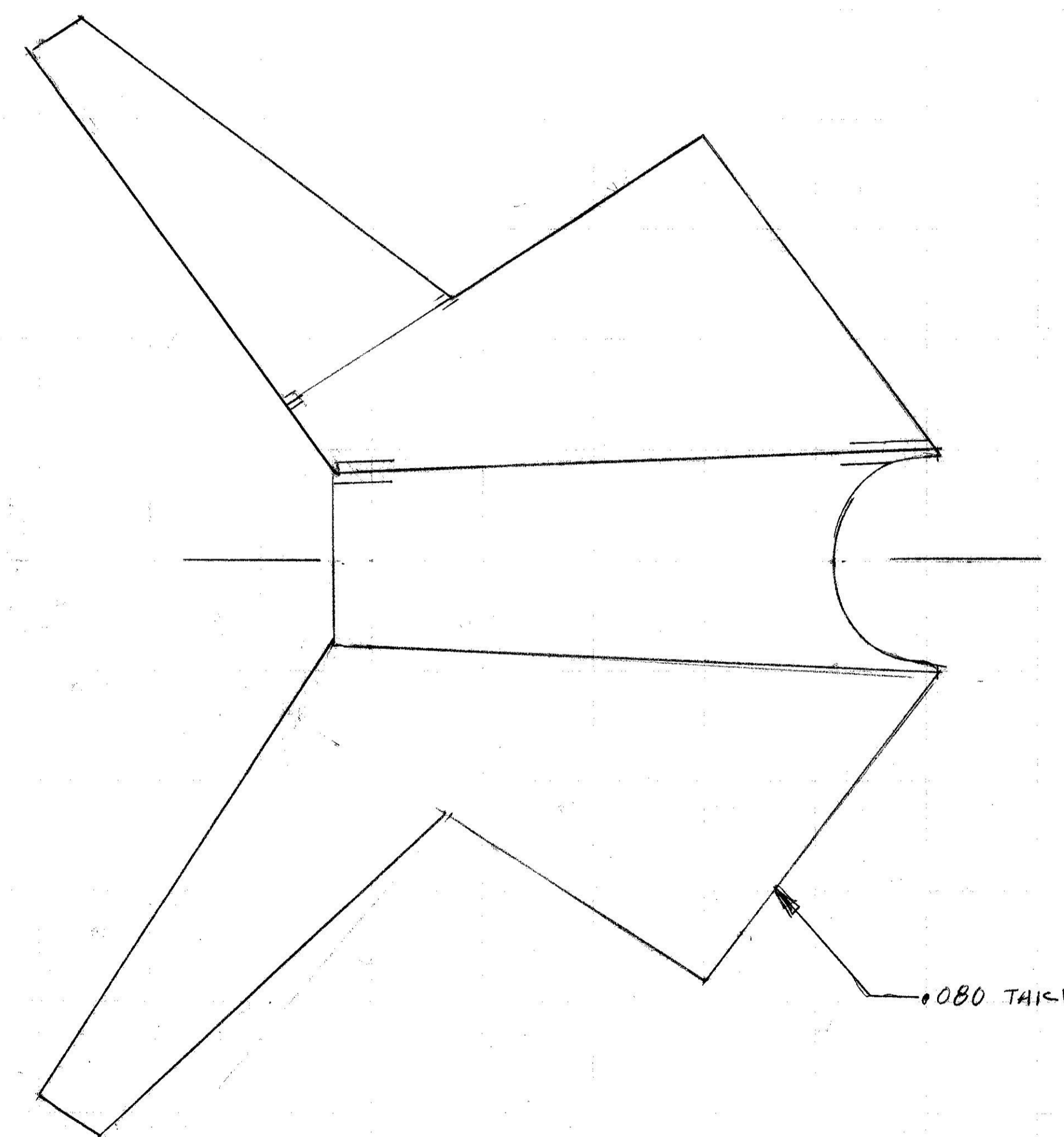
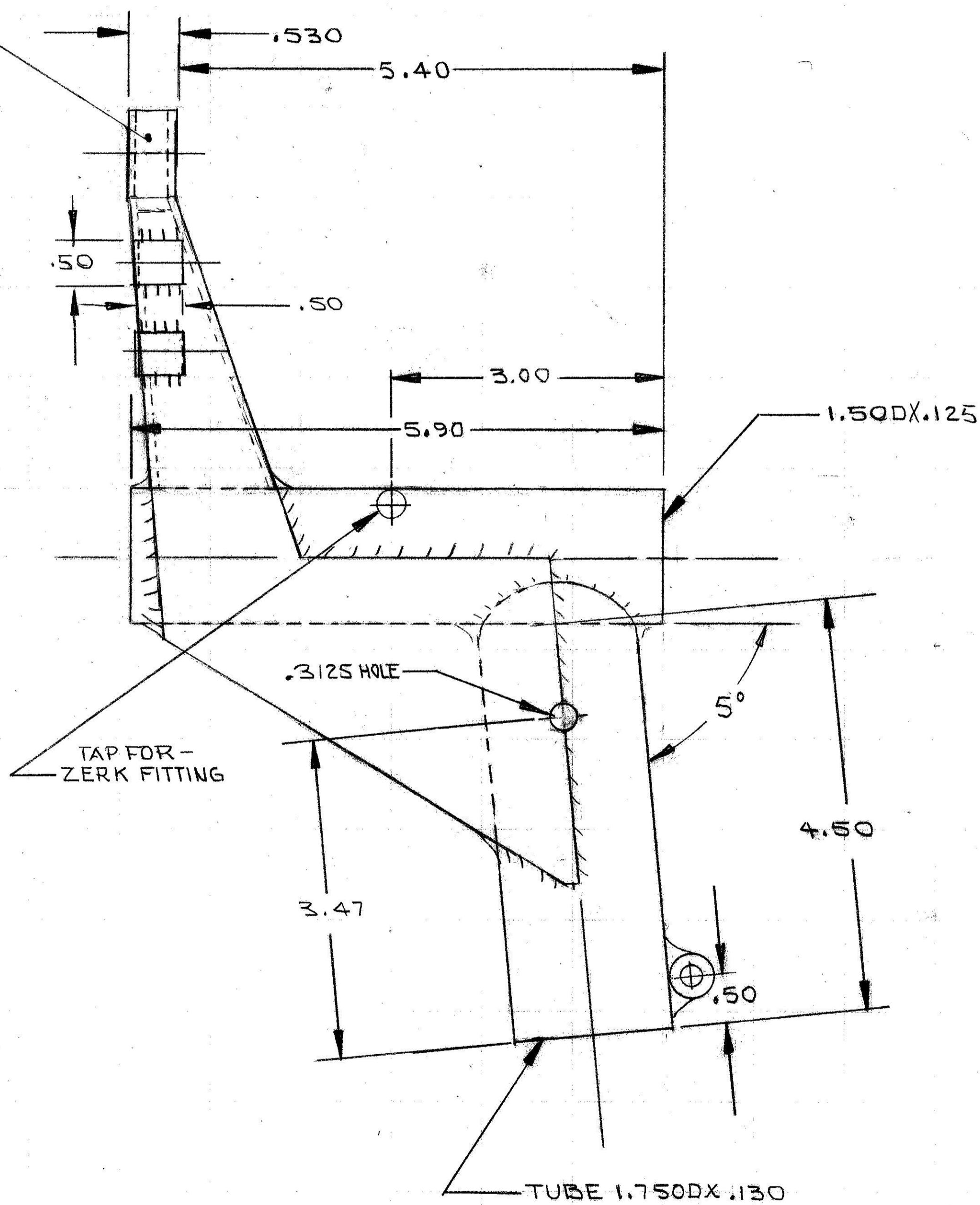

TEMPLATE

- 1 LEFT SIDE SHOWN
- 2 RIGHT SIDE OPPOSITE

AERO-SYSTEMS WICHITA, KS 67212	
LANDING GEAR UPPER RETRACT TRUNION	
CADET MODEL STF	
DRAWN BY N. LA FRANCE	SCALE 1/1
DATE 9-10-90	DRAWING NO. 091